

ME

TRANSISTORS & ICs DATABOOK

ISSUE 1

TRANSISTORS & ICs DATABOOK

ISSUE 1

MICRO ELECTRONIC LTD.

Since 1964 Micro Electronics Ltd. has been an independent manufacturer supplying more than 4000 types of solid-state devices. This databook contains the information of 560 master types only. Should you require a device not included, or a particular one designed to your own specifications, please contact M.E.L. regional sales offices and distributors.

— CONTENTS —

- * APPLICATIONS OF NON-REGISTERED TYPES
- * DEVICE SELECTION GUIDE
- * DATA SHEETS :

BC	MEU
BD	MH
BF	ML
CL	MPS
CX	MSB
D	PN
EN	RN
FPT	S
KM	2N
LN	2SA
MAS	2SB
MD	2SC
MEL	2SD
- * MECHANICAL OUTLINES

APPLICATIONS OF NON-REGISTERED TYPES

APPLICATIONS REFERENCE DATA SHEETS	APPLICATIONS REFERENCE DATA SHEETS
<p>MULTIBAND RADIO KM types</p> <p>PORTABLE TV CX types</p> <p>AUDIO AMPLIFIER</p> <p>Low Gain (20V) KM901 *</p> <p>High Gain (20V) KM9014 *</p> <p>Low Noise (25V) LN9014</p> <p>Driver 0.1A/40V CX904 *</p> <p> 0.5A/40V CX906 *</p> <p> 1A/40V CX908 *</p> <p> 1A/60V CL855 *</p> <p> 1A/80V MH8108 *</p> <p>Output 0.5 ~ 1W CL055 *</p> <p> 1.5 ~ 2W CL155 *</p> <p> 3 ~ 5W MH8100 *</p> <p> 7 ~ 15W MH8700 *</p> <p> 18 ~ 25W MH8500</p> <p> 30W up CX705A</p> <p>* Also suitable for medium speed switching and universal applications.</p> <p>LOW VCE(sat) @ 1A CL155</p> <p>DARLINGTON AMPLIFIER MPS-A13</p>	<p>GERMANIUM REPLACEMENT MSB492</p> <p>27 MHz LOW POWER MPS8000 PN2222</p> <p>PHOTO DETECTOR</p> <p>$I_L \approx 50 \mu A$ MEL31</p> <p>$I_L \approx 1mA$ FPT100</p> <p>$I_L \approx 5mA$ MEL11</p> <p>$I_L \approx 15mA$ up CL138</p> <p>Silicon Chip S110</p> <p>TRIGGERING & TIMING</p> <p>3-terminal type MEU21</p> <p>4-terminal type MAS32</p> <p>HIGH VOLTAGE</p> <p>0.1A (TO-92) CX703</p> <p>0.1A (TO-220) MH7301</p> <p>2A (TO-220) CX701</p> <p>5A (TO-220) CX702</p> <p>INTERGRATED CIRCUIT</p> <p>Digital Alarm Clock MD8009</p> <p>Precision Timer ML555</p> <p>Digit Driver ML1060</p> <p>Voltage Regulator ML2005</p> <p>V-F Converter ML9400</p> <p>BLINKING TOY KIT D20.U20</p>

NOTE : For Miniature Transistors, see BC146, BC200.
For N-Channel JFETs, see 2N3823.
For Rectifiers and LEDs, see individual catalogues.

DEVICE SELECTION GUIDE

V _{CEO} , HFE (Note)		USE	RF-IF SMALL SIGNAL		GENERAL PURPOSE AMPLIFIERS AND MEDIUM SPEED SWITCHES						HIGH VOLTAGE	
			$t_r \approx 600\text{MHz}$	$t_r \approx 400\text{MHz}$	Low Noise	IC $\approx 0.1\text{A}$	IC $\approx 0.5\text{A}$	IC $\approx 1\text{A}$	IC $\approx 3\text{A}$	IC $\approx 7\text{A}$	IC $\approx 0.1\text{A}$	
DEVICE TYPE	DATA SHEET	CASE										
BC107		TO-18					45B					
BC108	BC107	TO-18					20B					
BC109	BC107	TO-18			20B							
BC140		TO-39							40A			
BC141	BC140	TO-39							60Y			
BC146		MT-42 (Miniature)			20B							
BC160		TO-39							-40A			
BC161	BC160	TO-39							-60Y			
BC167	BC107	TO-92B					45B					
BC168	BC107	TO-92B					20B					
BC169	BC107	TO-92B			20B							
BC177		TO-18					-45B					
BC178	BC177	TO-18					-25B					
BC179	BC177	TO-18			-20B							
BC182		TO-92F						50A				
BC200		MT-42 (Miniature)			-20A							
BC204	BC177	TO-106					-45B					
BC205	BC177	TO-106					-20B					
BC206	BC177	TO-106			-20B							
BC207	BC107	TO-106					45B					
BC208	BC107	TO-106					25B					
BC209	BC107	TO-106			25B							
BC212	BC182	TO-92F						-50A				
BC237	BC107	TO-92F					45B					
BC238	BC107	TO-92F					20B					
BC239	BC107	TO-92F			20B							
BC257	BC177	TO-92B					-45B					
BC258	BC177	TO-92B					-25B					
BC259	BC177	TO-92B			-20B							
BC286		TO-39							60Y			
BC287	BC286	TO-39							-60Y			
BC300		TO-39							80Y			
BC301	BC300	TO-39							60Y			
BC302	BC300	TO-39							45A			
BC303		TO-39							-60Y			
BC304	BC303	TO-39							-45A			

Note: (1) V_{CEO} in volts, positive value for NPN and negative value for PNP.

(2) HFE in X, Y, A, B, C categories. X \approx 65, Y \approx 100, A \approx 165, B \approx 300, C \approx 500.

DEVICE SELECTION GUIDE

V _{CEO} , H _{FE} (Note)		USE	RF-IF		GENERAL PURPOSE AMPLIFIERS AND MEDIUM SPEED SWITCHES							HIGH VOLTAGE
			SMALL SIGNAL		Low Noise	I _C ≈ 0.1A	I _C ≈ 0.5A	I _C ≈ 1A	I _C ≈ 3A	I _C ≈ 7A	I _C ≈ 0.1A	
DEVICE TYPE	DATA SHEET	CASE	f _T ≈ 600MHz	f _T ≈ 400MHz								
BC307	BC177	TO-92F										
BC308	BC177	TO-92F										
BC309	BC177	TO-92F			-20B							
BC317	BC107	TO-92A				45B						
BC318	BC107	TO-92A				30B						
BC319	BC107	TO-92A			20B							
BC320	BC177	TO-92A				-45B						
BC321	BC177	TO-92A				-30B						
BC322	BC177	TO-92A			-20B							
BC327		TO-92F						-45A				
BC328	BC327	TO-92F						-25A				
BC337		TO-92F						45A				
BC338	BC337	TO-92F						25A				
BC413		TO-92F			30B							
BC414	BC413	TO-92F			45B							
BC415	BC413	TO-92F			-35B							
BC416	BC413	TO-92F			-45B							
BC431		TO-92F						60Y				
BC432	BC431	TO-92F						-60Y				
BC440		TO-39						40A				
BC441	BC440	TO-39						60Y				
BC460	BC440	TO-39						-40A				
BC461	BC440	TO-39						-60Y				
BC527		TO-92A						-60Y				
BC528	BC527	TO-92A						-80Y				
BC537		TO-92A						60Y				
BC538	BC537	TO-92A						80Y				
BC546		TO-92F				65A						
BC547	BC546	TO-92F				45B						
BC548	BC546	TO-92F				30B						
BC549	BC546	TO-92F			30B							
BC550	BC546	TO-92F			45B							
BC556		TO-92F						-65A				
BC557	BC556	TO-92F						-45B				
BC558	BC556	TO-92F						-30B				
BC559	BC556	TO-92F			-30B							

Note: (1) V_{CEO} in volts, positive value for NPN and negative value for PNP.

(2) H_{FE} in X, Y, A, B, C categories. X≈65, Y≈100, A≈165, B≈300, C≈500.

DEVICE SELECTION GUIDE

V _{CEO} , HFE (Note)		USE	RF-IF SMALL SIGNAL		GENERAL PURPOSE AMPLIFIERS AND MEDIUM SPEED SWITCHES					HIGH VOLTAGE		
DEVICE TYPE	DATA SHEET		CASE	f _T ≈ 600MHz	f _T ≈ 400MHz	Low Noise	I _C ≈ 0.1A	I _C ≈ 0.5A	I _C ≈ 1A	I _C ≈ 3A	I _C ≈ 7A	I _C ≈ 0.1A
BC560	BC566	TO-92F			-45B							
BC727		TO-92A										
BC728	BC727	TO-92A										
BC737		TO-92A										
BC738	BC737	TO-92A										
BD220		TO-220B								70X (low speed)		
BD221	BD220	TO-220B								40X (low speed)		
BD222	BD220	TO-220B								60X (low speed)		
BD239		TO-220B								45Y		
BD239A	BD239	TO-220B								60Y		
BD239B	BD239	TO-220B								80X		
BD239C		TO-220B								100X		
BD240		TO-220B								-45Y		
BD240A	BD240	TO-220B								-60Y		
BD240B	BD240	TO-220B								-80X		
BD240C	BD239C	TO-220B								-100X		
BD241		TO-220B								45Y		
BD241A	BD241	TO-220B								60Y		
BD241B	BD241	TO-220B								80X		
BD241C	BD239C	TO-220B								100X		
BD242		TO-220B								-45Y		
BD242A	BD242	TO-220B								-60Y		
BD242B	BD242	TO-220B								-80X		
BD242C	BD239C	TO-220B								-100X		
BD533		TO-220B								45Y		
BD534		TO-220B								-45Y		
BD535	BD533	TO-220B								60Y		
BD536	BD534	TO-220B								-60Y		
BD537	BD533	TO-220B								80X		
BD538	BD534	TO-220B								-80X		
BD633		TO-220B								45Y		
BD634	BD633	TO-220B								-45Y		
BD635	BD633	TO-220B								60Y		

Note: (1) V_{CEO} in volts, positive value for NPN and negative value for PNP.

(2) HFE in X, Y, A, B, C categories. X ≈ 65, Y ≈ 100, A ≈ 165, B ≈ 300, C ≈ 500.

DEVICE SELECTION GUIDE

V _{CEO} , HFE (Note)		USE CASE	RF-IF SMALL SIGNAL		GENERAL PURPOSE AMPLIFIERS AND MEDIUM SPEED SWITCHES					HIGH VOLTAGE
			f _T ≈ 600MHz	f _T ≈ 400MHz	Low Noise	I _C ≈ 0.1A	I _C ≈ 0.5A	I _C ≈ 1A	I _C ≈ 3A	I _C ≈ 7A
DEVICE TYPE	DATA SHEET									
BD636	BD633	TO-220B							-60Y	
BD637	BD633	TO-220B							80X	
BD638	BD633	TO-220B							-80X	
BF158		TO-106	12X							
BF159	BF158	TO-106	20X							
BF160	BF158	TO-106	12X							
BF244	2N3823	TO-92DA	N-JFET							
BF245	2N3823	TO-92DE	N-JFET							
BF254		TO-92E		20Y						
BF255	BF254	TO-92E		20X						
BF256	2N3823	TO-92DE	N-JFET							
BF257		TO-39								160Y
BF258	BF257	TO-39								250Y
BF259	BF257	TO-39								300X
BF297		TO-92F								160Y
BF298	BF297	TO-92F								250Y
BF299	BF297	TO-92F								300X
BF336		TO-39								180Y
BF337	BF336	TO-39								200Y
BF338	BF336	TO-39								225X
BF368		TO-92A	15X							
BF369	BF368	TO-92A	20Y							
BF391		TO-92A								200Y
BF392	BF391	TO-92A								250Y
BF393	BF391	TO-92A								300X
BF494		TO-92E		20Y						
BF495	BF494	TO-92E		20X						
CL055		TO-92A							-20A (low V _{CEK})	
CL066	CL055	TO-92A							20A (low V _{CEK})	
CL138		TO-106	Photo Darlington Transistor							

Note: (1) V_{CEO} in volts, positive value for NPN and negative value for PNP.

(2) HFE in X, Y, A, B, C categories. X ≈ 65, Y ≈ 100, A ≈ 165, B ≈ 300, C ≈ 500.

DEVICE SELECTION GUIDE

V _{CEO} , H _{FE} (Note)		USE	RF-IF		GENERAL PURPOSE AMPLIFIERS AND MEDIUM SPEED SWITCHES						HIGH VOLTAGE
			SMALL SIGNAL		Low Noise	IC ≈ 0.1A	IC ≈ 0.5A	IC ≈ 1A	IC ≈ 3A	IC ≈ 7A	IC ≈ 0.1A
DEVICE TYPE	DATA SHEET	CASE	f _T ≈ 600MHz	f _T ≈ 400MHz							
CL155		TO-92A							-25A (low VCEK)		
CL166	CL155	TO-92A							25A (low VCEK)		
CL855		TO-92A							-60Y		
CL866	CL855	TO-92A							60Y		
CX701		TO-220B								120X	
CX701A	CX701	TO-220B								150X	
CX702		TO-220B									80X
CX702A	CX702	TO-220B									100X
CX703		TO-92A									160Y
CX703A	CX703	TO-92A									200Y
CX703B	CX703	TO-92A									250X
CX704		TO-220B							50Y		
CX705		TO-3									45X (low speed)
CX705A	CX705	TO-3									60X (low speed)
CX754	CX704	TO-220B							-50Y		
CX901		TO-92A				40X					
CX904		TO-92A				40B					
CX906		TO-92A					40A				
CX908		TO-92A						40A			
CX917		TO-92A		30X							
CX918		TO-92A	20X								
CX954	CX904	TO-92A									
CX956	CX906	TO-92A									
CX958	CX908	TO-92A									
D20.U20											
D44C		TO-220B								30 ~ 80X	
D45C		TO-220B								-30 ~ -80X	
											Blinking Toy Kit

Note: (1) V_{CEO} in volts, positive value for NPN and negative value for PNP.
 (2) H_{FE} in X, Y, A, B, C categories. X≈65, Y≈100, A≈165, B≈300, C≈500.

DEVICE SELECTION GUIDE

V _{CEO} , HFE (Note)		USE CASE	RF-IF SMALL SIGNAL		GENERAL PURPOSE AMPLIFIERS AND MEDIUM SPEED SWITCHES						HIGH VOLTAGE	
DEVICE TYPE	DATA SHEET		f _T ≈ 600MHz	f _T ≈ 400MHz	Low Noise	I _C ≈ 0.1A	I _C ≈ 0.5A	I _C ≈ 1A	I _C ≈ 3A	I _C ≈ 7A	I _C ≈ 0.1A	
EN930		TO-106			45B							
FPT100		TO-106	Photo Transistor									
FPT100A	FPT100	TO-106	Photo Transistor									
FPT100B	FPT100	TO-106	Photo Transistor									
KM901	KM PRODUCT LINE	TO-92A					20X					Ideal for FM/AM and radio control applications.
KM904		TO-92A						20A				
KM905		TO-92A							-20A			
KM917		TO-92A										
KM918		TO-92A		20X								
KM928		TO-92A		20X								
KM934		TO-92A							30A			
KM935		TO-92A							-30A			
KM9014		TO-92A								20B		
KM9015		TO-92A								-20B		
LN9014		TO-92A			25B							
LN9015	LN9014	TO-92A			-25B							
MAS32		TO-72	Silicon Controlled Switch									
MAS39		TO-72	Silicon Controlled Switch									
MD8009			Digital Alarm Clock (I.C.)									
MEL11		TO-106	Photo Darlington Transistor									
MEL12	MEL11	TO-106	Photo Darlington Transistor									
MEL31		TO-106	Photo Transistor									

Note: (1) V_{CEO} in volts, positive value for NPN and negative value for PNP.

(2) HFE in X, Y, A, B, C categories. X ≈ 65, Y ≈ 100, A ≈ 165, B ≈ 300, C ≈ 500.

DEVICE SELECTION GUIDE

V _{CEO} , HFE (Note)		USE	RF-IF		GENERAL PURPOSE AMPLIFIERS AND MEDIUM SPEED SWITCHES						HIGH
			SMALL SIGNAL								VOLTAGE
DEVICE TYPE	DATA SHEET	CASE	f _T ≈ 600MHz	f _T ≈ 400MHz	Low Noise	I _C ≈ 0.1A	I _C ≈ 0.5A	I _C ≈ 1A	I _C ≈ 3A	I _C ≈ 7A	I _C ≈ 0.1A
MEL32	MEL31	TO-106	Photo Transistor								
MEU21		TO-106	Programmable Unijunction Transistor								
MEU22	MEU21	TO-106	Programmable Unijunction Transistor								
MH0810	MH8100	TO-220B							-30Y		
MH0816	MH8106	TO-220B						-60Y			
MH0818	MH8106	TO-220B						-80Y			
MH0850	MH8500	TO-220B								-60Y	
MH0870	MH8700	TO-220B							-50Y		
MH7301		TO-220B									160Y
MH7302	MH7301	TO-220B									200Y
MH7303	MH7301	TO-220B									250X
MH8100		TO-220B							30Y		
MH8106		TO-220B						60Y			
MH8108		TO-220B						80Y			
MH8500		TO-220B								60Y	
MH8700		TO-220B							50Y		
ML555			Timer (I.C.)								
ML1060			Digit Driver (I.C.)								
ML2005			5-Volt Voltage Regulator (I.C.)								
ML9400			Voltage to Frequency Converter (I.C.)								
MPS2711	MPS8565	TO-92A				18X					
MPS2712	MPS8565	TO-92A				18A					
MPS2716	MPS8565	TO-92A				18A					
MPS2923	MPS8565	TO-92A				25Y					

Note: (1) V_{CEO} in volts, positive value for NPN and negative value for PNP.

(2) HFE in X, Y, A, B, C categories. X≈65, Y≈100, A≈165, B≈300, C≈500.

DEVICE SELECTION GUIDE

V_{CE0} , H_{FE} (Note)		USE	RF-IF		GENERAL PURPOSE AMPLIFIERS AND MEDIUM SPEED SWITCHES						HIGH	
			SMALL SIGNAL		Low Noise	$I_C \approx 0.1A$	$I_C \approx 0.5A$	$I_C \approx 1A$	$I_C \approx 3A$	$I_C \approx 7A$	$I_C \approx 0.1A$	
			$f_T \approx 600MHz$	$f_T \approx 400MHz$								
DEVICE TYPE	DATA SHEET	CASE										
MPS2924	MPS6565	TO-92A				25A						
MPS2925	MPS6565	TO-92A				25B						
MPS3390	MPS6565	TO-92A				25C						
MPS3391	MPS6565	TO-92A				25B						
MPS3392	MPS6565	TO-92A				25A						
MPS3393	MPS6565	TO-92A				25Y						
MPS3394	MPS6565	TO-92A				25X						
MPS3395	MPS6565	TO-92A				25B						
MPS3396	MPS6565	TO-92A				25A						
MPS3397	MPS6565	TO-92A				25A						
MPS3398	MPS6565	TO-92A				25B						
MPS3638		TO-92A					-25Y					
MPS3638A	MPS3638	TO-92A					-25A					
MPS3702	2N3702	TO-92A					-25A					
MPS3703	2N3702	TO-92A					-30Y					
MPS3704	2N3702	TO-92A					30A					
MPS3705	2N3702	TO-92A					30Y					
MPS3706	2N3702	TO-92A					20A					
MPS3707	MPS6565	TO-92A				30B						
MPS3708	MPS6565	TO-92A				30B						
MPS3709	MPS6565	TO-92A				30Y						
MPS3710	MPS6565	TO-92A				30A						
MPS3711	MPS6565	TO-92A				30B						
MPS4354		TO-92A						-60Y				
MPS4355	MPS4354	TO-92A						-60A				
MPS4356	MPS4354	TO-92A						-80Y				
MPS5172	MPS6565	TO-92A				25B						
MPS6512	MPS6565	TO-92A				30X						
MPS6513	MPS6565	TO-92A				30Y						
MPS6530		TO-92A					40Y					
MPS6531	MPS6530	TO-92A					40A					
MPS6532	MPS6530	TO-92A					30Y					
MPS6533	MPS6530	TO-92A					-40Y					
MPS6534	MPS6530	TO-92A					-40A					
MPS6535	MPS6530	TO-92A					-30Y					
MPS6560		TO-92A						25A				

Note: (1) V_{CE0} in volts, positive value for NPN and negative value for PNP.

(2) H_{FE} in X, Y, A, B, C categories. X \approx 65, Y \approx 100, A \approx 165, B \approx 300, C \approx 500.

DEVICE SELECTION GUIDE

V _{CEO} , HFE (Note)		USE	RF-IF SMALL SIGNAL		GENERAL PURPOSE AMPLIFIERS AND MEDIUM SPEED SWITCHES						HIGH VOLTAGE	
DEVICE TYPE	DATA SHEET		CASE	f _T ≈ 600MHz	f _T ≈ 400MHz	Low Noise	I _C ≈ 0.1A	I _C ≈ 0.5A	I _C ≈ 1A	I _C ≈ 3A	I _C ≈ 7A	I _C ≈ 0.1A
MPS6561	MPS6560	TO-92A								20A		
MPS6562	MPS6560	TO-92A								-25A		
MPS6563	MPS6560	TO-92A								-20A		
MPS6565		TO-92A				45Y						
MPS6566	MPS6565	TO-92A				45A						
MPS6573	MPS6565	TO-92A				35B						
MPS6574	MPS6565	TO-92A				35A						
MPS6575	MPS6565	TO-92A				45B						
MPS6576	MPS6565	TO-92A				45A						
MPS8000		TO-92A								30A(27MHz)		
MPSA05		TO-92A								60Y		
MPSA06	MPSA05	TO-92A								80Y		
MPSA13		TO-92A										
MPSA14	MPSA13	TO-92A										
MPSA20		TO-92A										
MPSA42		TO-92A					40A					
MPSA43	MPSA42	TO-92A									300X	
MPSA55	MPSA05	TO-92A								-60Y	200Y	
MPSA56	MPSA05	TO-92A								-80Y		
MPSA65	MPSA13	TO-92A										
MPSA66	MPSA13	TO-92A										
MPSA70	MPSA20	TO-92A										
MPSD01		TO-92A										200Y
MPSD05		TO-92A										
MPSD55	MPSD05	TO-92A						25A				
								-25A				
MPSL01		TO-92A										120Y

Note: (1) V_{CEO} in volts, positive value for NPN and negative value for PNP.

(2) HFE in X, Y, A, B, C categories. X ≈ 65, Y ≈ 100, A ≈ 165, B ≈ 300, C ≈ 500.

DEVICE SELECTION GUIDE

V _{CEO} , HFE (Note)		USE	RF-IF SMALL SIGNAL		GENERAL PURPOSE AMPLIFIERS AND MEDIUM SPEED SWITCHES						HIGH VOLTAGE	
DEVICE TYPE	DATA SHEET		CASE	f _T ≈ 600MHz	f _T ≈ 400MHz	Low Noise	IC ≈ 0.1A	IC ≈ 0.5A	IC ≈ 1A	IC ≈ 3A	IC ≈ 7A	IC ≈ 0.1A
SE4010	EN930	TO-106			45B							
2N930		TO-18			45B							
2N2102		TO-39						65Y				
2N2222		TO-18					30A					
2N2222A	2N2222	TO-18					40A					
2N2586		TO-18			45B							
2N2711	MPS6565	TO-92B				18X						
2N2712	MPS6565	TO-92B				18A						
2N2716	MPS6565	TO-92B				18A						
2N2907		TO-18										
2N2907A	2N2907	TO-18										
2N2923	MPS6565	TO-92B					25Y					
2N2924	MPS6565	TO-92B					25A					
2N2925	MPS6565	TO-92B					25B					
2N3019		TO-39										
2N3020	2N3019	TO-39								80A		
2N3053		TO-39								80Y		
2N3107		TO-39								40A		
2N3108	2N3107	TO-39								60A		
2N3109	2N3107	TO-39								60Y		
2N3110	2N3107	TO-39								40A		
2N3110	2N3107	TO-39								40Y		
2N3390	MPS6565	TO-92B				25C						
2N3391	MPS6565	TO-92B				25B						
2N3392	MPS6565	TO-92B				25A						
2N3393	MPS6565	TO-92B				25A						
2N3393	MPS6565	TO-92B				25Y						
2N3394	MPS6565	TO-92B				25X						
2N3395	MPS6565	TO-92B				25B						
2N3396	MPS6565	TO-92B				25A						
2N3397	MPS6565	TO-92B				25A						
2N3398	MPS6565	TO-92B				25B						
2N3402	2N3702	TO-92B								25A		
2N3403	2N3702	TO-92B								25B		
2N3404	2N3702	TO-92B								50A		

Note: (1) V_{CEO} in volts, positive value for NPN and negative value for PNP.

(2) HFE in X, Y, A, B, C categories. X ≈ 65, Y ≈ 100, A ≈ 165, B ≈ 300, C ≈ 500.

DEVICE SELECTION GUIDE

V _{CEO} , HFE (Note)		USE CASE	RF-IF SMALL SIGNAL		GENERAL PURPOSE AMPLIFIERS AND MEDIUM SPEED SWITCHES						HIGH VOLTAGE
DEVICE TYPE	DATA SHEET		f _T ≈ 600MHz	f _T ≈ 400MHz	Low Noise	IC ≈ 0.1A	IC ≈ 0.5A	IC ≈ 1A	IC ≈ 3A	IC ≈ 7A	IC ≈ 0.1A
2N3405	2N3702	TO-92B									
2N3414	2N3702	TO-92B									
2N3415	2N3702	TO-92B									
2N3416	2N3702	TO-92B									
2N3417	2N3702	TO-92B									
2N3548	2N930	TO-18			-45B						
2N3563		TO-106	12Y								
2N3565		TO-106				25B					
2N3691		TO-106				25Y					
2N3692	2N3691	TO-106				25A					
2N3693	2N3691	TO-106		45Y							
2N3694	2N3691	TO-106		45A							
2N3702		TO-92B									
2N3703	2N3702	TO-92B								-25A	
2N3704	2N3702	TO-92B								-30Y	
2N3705	2N3702	TO-92B								30A	
2N3705	2N3702	TO-92B								30Y	
2N3706	2N3702	TO-92B								20A	
2N3707		TO-92B									
2N3708	2N3707	TO-92B								30B	
2N3709	2N3707	TO-92B								30B	
2N3709	2N3707	TO-92B								30Y	
2N3710	2N3707	TO-92B								30A	
2N3711	2N3707	TO-92B								30B	
2N3819	2N3823	TO-92DA	N-JFET								
2N3823		TO-72	N-JFET								
2N3825		TO-92B	15X								
2N3827	2N3825	TO-92B		45A							
2N3843	2N3691	TO-92B									
2N3843A	2N3691	TO-92B									
2N3844	2N3691	TO-92B									
2N3844A	2N3691	TO-92B									
2N3845	2N3691	TO-92B									
2N3845A	2N3691	TO-92B									
2N3854	2N3691	TO-92B									
2N3854A	2N3691	TO-92B									
2N3855	2N3691	TO-92B									
2N3855A	2N3691	TO-92B									
2N3855A	2N3691	TO-92B									

Note: (1) V_{CEO} in volts, positive value for NPN and negative value for PNP.

(2) HFE in X, Y, A, B, C categories. X ≈ 65, Y ≈ 100, A ≈ 165, B ≈ 300, C ≈ 500.

DEVICE SELECTION GUIDE

V _{CEO} , HFE (Note)		USE	RF-IF		GENERAL PURPOSE AMPLIFIERS AND MEDIUM SPEED SWITCHES						HIGH	
			SMALL SIGNAL		Low Noise	IC ≈ 0.1A	IC ≈ 0.5A	IC ≈ 1A	IC ≈ 3A	IC ≈ 7A	IC ≈ 0.1A	
DEVICE TYPE	DATA SHEET	CASE	f _T ≈ 600MHz	f _T ≈ 400MHz								
2N3856	2N3691	TO-92B		18A								
2N3856A	2N3691	TO-92B		30A								
2N3858	2N3691	TO-92B				30Y						
2N3859	2N3691	TO-92B				30A						
2N3860	2N3691	TO-92B				30A						
2N3964	2N2586	TO-18			-45B							
2N4030		TO-39							-60Y			
2N4031	2N4030	TO-39							-80Y			
2N4032	2N4030	TO-39							-60A			
2N4033	2N4030	TO-39							-80A			
2N4036	2N2102	TO-39							-65Y			
2N4037	2N3053	TO-39							-40A			
2N4058	2N3707	TO-92B				-30B						
2N4059	2N3707	TO-92B				-30B						
2N4060	2N3707	TO-92B				-30Y						
2N4061	2N3707	TO-92B				-30A						
2N4062	2N3707	TO-92B				-30B						
2N4234		TO-39							-40Y			
2N4235	2N4234	TO-39							-60Y			
2N4237	2N4234	TO-39							40Y			
2N4238	2N4234	TO-39							60Y			
2N4248		TO-106			-40A							
2N4249	2N4248	TO-106			-60A							
2N4250	2N4248	TO-106			-40C							
2N4302	2N3823	TO-106	N-JFET									
2N4303	2N3823	TO-106	N-JFET									
2N4304	2N3823	TO-106	N-JFET									
2N4400		TO-92A							40Y			
2N4401	2N4400	TO-92A							40A			
2N4402		TO-92A							-40Y			
2N4403	2N4402	TO-92A							-40A			
2N4416	2N3823	TO-72	N-JFET									
2N4424	2N3702	TO-92B							40B			
2N4425	2N3702	TO-92B							40B			
2N4926		TO-39									200Y	
2N4927	2N4926	TO-39									250Y	

Note: (1) V_{CEO} in volts, positive value for NPN and negative value for PNP.

(2) HFE in X, Y, A, B, C categories. X ≈ 65, Y ≈ 100, A ≈ 165, B ≈ 300, C ≈ 500.

DEVICE SELECTION GUIDE

DEVICE TYPE	DATA SHEET	USE CASE	RF-IF SMALL SIGNAL		GENERAL PURPOSE AMPLIFIERS AND MEDIUM SPEED SWITCHES						HIGH VOLTAGE	
			$f_T \approx 600\text{MHz}$	$f_T \approx 400\text{MHz}$	Low Noise	IC $\approx 0.1\text{A}$	IC $\approx 0.5\text{A}$	IC $\approx 1\text{A}$	IC $\approx 3\text{A}$	IC $\approx 7\text{A}$	IC $\approx 0.1\text{A}$	
2N4964		TO-106										
2N4965	2N4964	TO-106										
2N4966	2N4964	TO-106										
2N4967	2N4964	TO-106										
2N4968	2N4964	TO-106										
2N4994		TO-92F		45Y								
2N4995	2N4994	TO-92F		45A								
2N5086		TO-92A										
2N5087	2N5086	TO-92A										
2N5088	2N5086	TO-92A										
2N5089	2N5086	TO-92A										
2N5103	2N3823	TO-72	N-JFET									
2N5104	2N3823	TO-72	N-JFET									
2N5130	2N3563	TO-106	12X									
2N5132	2N3563	TO-106		20X								
2N5138	2N3565	TO-106										
2N5163	2N3823	TO-106	N-JFET									
2N5172	MPS6665	TO-92B										
2N5209		TO-92A										
2N5210	2N5209	TO-92A										
2N5220	2N3702	TO-92A										
2N5221	2N3702	TO-92A										
2N5225	2N3702	TO-92A										
2N5226	2N3702	TO-92A										
2N5232	2N3691	TO-92B										
2N5232A	2N3691	TO-92B										
2N5245	2N3823	TO-92DE	N-JFET									
2N5246	2N3823	TO-92DE	N-JFET									
2N5247	2N3823	TO-92DE	N-JFET									
2N5248	2N3823	TO-92DA	N-JFET									
2N5294		TO-220B										
2N5296	2N5294	TO-220B										
2N5298	2N5294	TO-220B										
2N5354	2N3702	TO-92B										
2N5355	2N3702	TO-92B										
2N5356	2N3702	TO-92B										

Note: (1) V_{CEO} in volts, positive value for NPN and negative value for PNP.

(2) HFE in X, Y, A, B, C categories. X \approx 65, Y \approx 100, A \approx 165, B \approx 300, C \approx 500.

DEVICE SELECTION GUIDE

V _{CEO} , HFE (Note)		USE	RF-IF SMALL SIGNAL		GENERAL PURPOSE AMPLIFIERS AND MEDIUM SPEED SWITCHES						HIGH VOLTAGE	
DEVICE TYPE	DATA SHEET		CASE	f _T ≈ 600MHz	f _T ≈ 400MHz	Low Noise	I _C ≈ 0.1A	I _C ≈ 0.5A	I _C ≈ 1A	I _C ≈ 3A	I _C ≈ 7A	I _C ≈ 0.1A
2N5385	2N3702	TO-92B					-40Y					
2N5386	2N3702	TO-92B					-40A					
2N5367	2N3702	TO-92B					-40B					
2N5368	2N5368	TO-92F					30Y					
2N5369	2N5368	TO-92F					30A					
2N5370	2N5368	TO-92F					30B					
2N5371		TO-92F					30A					
2N5372	2N5368	TO-92F					-30Y					
2N5373	2N5368	TO-92F					-30A					
2N5374	2N5368	TO-92F					-30B					
2N5375	2N5368	TO-92F					-30A					
2N5400		TO-92A									-120Y	
2N5401	2N5400	TO-92A									-150Y	
2N5418	2N3702	TO-92B					25Y					
2N5419	2N3702	TO-92B					25A					
2N5420	2N3702	TO-92B					25B					
2N5447		TO-92F					-25A					
2N5448	2N5447	TO-92F					-30Y					
2N5449	2N5447	TO-92F					30A					
2N5450	2N5447	TO-92F					30Y					
2N5451	2N3702	TO-92F					20A					
2N5457	2N3823	TO-92DD	N-JFET									
2N5458	2N3823	TO-92DD	N-JFET									
2N5459	2N3823	TO-92DD	N-JFET									
2N5484	2N3823	TO-92DD	N-JFET									
2N5485	2N3823	TO-92DD	N-JFET									
2N5486	2N3823	TO-92DD	N-JFET									
2N5490		TO-220B									40X (low speed)	
2N5492	2N5490	TO-220B									55X (low speed)	
2N5494	2N5490	TO-220B									40X (low speed)	
2N5496	2N5490	TO-220B									70X (low speed)	
2N5550	2N5400	TO-92A									140Y	
2N5551	2N5400	TO-92A									160A	
2N5556	2N3823	TO-72	N-JFET									
2N5557	2N3823	TO-72	N-JFET									
2N5558	2N3823	TO-72	N-JFET									

Note: (1) V_{CEO} in volts, positive value for NPN and negative value for PNP.

(2) HFE in X, Y, A, B, C categories. X≈65, Y≈100, A≈165, B≈300, C≈500.

DEVICE SELECTION GUIDE

V _{CEO} , HFE (Note)		USE CASE	RF-IF SMALL SIGNAL		GENERAL PURPOSE AMPLIFIERS AND MEDIUM SPEED SWITCHES						HIGH VOLTAGE
DEVICE TYPE	DATA SHEET		f _T ≈ 600MHz	f _T ≈ 400MHz	Low Noise	IC ≈ 0.1A	IC ≈ 0.5A	IC ≈ 1A	IC ≈ 3A	IC ≈ 7A	IC ≈ 0.1A
2N5668	2N3823	TO-92DD	N-JFET								
2N5669	2N3823	TO-92DD	N-JFET								
2N5670	2N3823	TO-92DD	N-JFET								
2N5810		TO-92F						25A			
2N5811	2N5810	TO-92F						-25A			
2N5812	2N5810	TO-92F						25B			
2N5813	2N5810	TO-92F						-25B			
2N5814	2N5810	TO-92F						40Y			
2N5815	2N5810	TO-92F						-40Y			
2N5816	2N5810	TO-92F						40A			
2N5817	2N5810	TO-92F						-40A			
2N5818	2N5810	TO-92F						40B			
2N5819	2N5810	TO-92F						-40B			
2N5820		TO-92F						60Y			
2N5821	2N5820	TO-92F						-60Y			
2N5822	2N5820	TO-92F						60A			
2N5823	2N5820	TO-92F						-60A			
2N5824		TO-92F									
2N5825	2N5824	TO-92F				40Y					
2N5826	2N5824	TO-92F				40A					
2N5827	2N5824	TO-92F				40A					
2N5828	2N5824	TO-92F				40B					
2N5828	2N5824	TO-92F				40C					
2N6027		TO-92	Programmable Unijunction Transistor								
2N6028	2N6027	TO-92	Programmable Unijunction Transistor								
2N6107	2N6111	TO-220B							-70X		
2N6109	2N6111	TO-220B							-50Y		
2N6111		TO-220B							-30Y		
2N6121		TO-220B						45X			
2N6122	2N6121	TO-220B						60X			
2N6123	2N6121	TO-220B						80X			
2N6124		TO-220B						-45X			
2N6125	2N6124	TO-220B						-60X			
2N6126	2N6124	TO-220B						-80X			
2N6129		TO-220B							40X		
2N6130	2N6129	TO-220B							60X		
2N6131	2N6129	TO-220B							80X		

Note: (1) V_{CEO} in volts, positive value for NPN and negative value for PNP.

(2) HFE in X, Y, A, B, C categories. X≈65, Y≈100, A≈165, B≈300, C≈500.

DEVICE SELECTION GUIDE

V_{CE0} , HFE (Note)		USE	RF-IF		GENERAL PURPOSE AMPLIFIERS AND MEDIUM SPEED SWITCHES						HIGH VOLTAGE
			SMALL SIGNAL		Low Noise	$I_C \approx 0.1A$	$I_C \approx 0.5A$	$I_C \approx 1A$	$I_C \approx 3A$	$I_C \approx 7A$	$I_C \approx 0.1A$
			$f_T \approx 600MHz$	$f_T \approx 400MHz$							
DEVICE TYPE	DATA SHEET	CASE									
2N6132		TO-220B									
2N6133	2N6132	TO-220B									
2N6134	2N6132	TO-220B									
2N6218		TO-92F									
2N6219	2N6218	TO-92F								300X	
2N6220	2N6218	TO-92F								250X	
2N6221	2N6218	TO-92F								200Y	
2N6288		TO-220B								150Y	
2N6290	2N6288	TO-220B								30Y	
2N6292	2N6288	TO-220B								50Y	
2N6473		TO-220B								70X	
2N6474	2N6473	TO-220B								100X	
2N6475	2N6473	TO-220B								120X	
2N6476	2N6473	TO-220B								-100X	
										-120X	
2SA473		TO-220B									
2SA489		TO-220B									
2SA490		TO-220B									
2SA539		TO-92B									
2SA564		TO-92B									
2SA564A		TO-92B									
2SA666		TO-92B									
2SA671		TO-220B									
2SA719		TO-92B									
2SA720		TO-92B									
2SA730		TO-92B									
2SA731		TO-92B									
2SA816		TO-220B									
2SA817		TO-92B									
2SB512		TO-220B									
2SB512A	2SB512	TO-220B									

Note: (1) V_{CE0} in volts, positive value for NPN and negative value for PNP.

(2) HFE in X, Y, A, B, C categories. $X \approx 65$, $Y \approx 100$, $A \approx 165$, $B \approx 300$, $C \approx 500$.

DEVICE SELECTION GUIDE

V _{CEO} , HFE (Note)		USE CASE	RF-IF SMALL SIGNAL		GENERAL PURPOSE AMPLIFIERS AND MEDIUM SPEED SWITCHES						HIGH VOLTAGE
DEVICE TYPE	DATA SHEET		f _T ≈ 600MHz	f _T ≈ 400MHz	Low Noise	IC ≈ 0.1A	IC ≈ 0.5A	IC ≈ 1A	IC ≈ 3A	IC ≈ 7A	IC ≈ 0.1A
2SB596	2SA489	TO-220B									
2SB604	2SA489	TO-220B								-80X -70X	
2SC644	2SA666	TO-92B			25B						
2SC789		TO-220B							60X		
2SC790	2SA490	TO-220B						40Y			
2SC815	2SA539	TO-92B				45Y					
2SC828	2SA564	TO-92B				25B					
2SC828A	2SA564	TO-92B				45B					
2SC829		TO-92B		20Y							
2SC838		TO-92B		25Y							
2SC839	2SC838	TO-92B		25Y							
2SC922		TO-92B	20Y								
2SC1047	2SC922	TO-92B	20Y								
2SC1048		TO-39								200Y	
2SC1061	2SA671	TO-220B						50Y			
2SC1173	2SA473	TO-220B						30A			
2SC1317	2SA719	TO-92B									
2SC1318	2SA719	TO-92B						25A 50A			
2SC1346	2SA719	TO-92B						25A			
2SC1347	2SA719	TO-92B						50A			
2SC1626	2SA816	TO-220B						80Y			
2SC1627	2SA817	TO-92B						80Y			
2SD234		TO-220B								50X (low speed)	
2SD235	2SD234	TO-220B								40X (low speed)	
2SD365	2SB512	TO-220B								60X	
2SD365A	2SB512	TO-220B								80X	
2SD526	2SC789	TO-220B								80X	
2SD570	2SC789	TO-220B								70X	

Note: (1) V_{CEO} in volts, positive value for NPN and negative value for PNP.

(2) HFE in X, Y, A, B, C categories. X≈65, Y≈100, A≈165, B≈300, C≈500.

BC107,8,9 BC167,8,9 BC207,8,9 BC237,8,9 BC317,8,9

NPN SILICON AF SMALL SIGNAL TRANSISTORS

THE ABOVE TYPES ARE NPN SILICON PLANAR EPITAXIAL TRANSISTORS FOR USE IN AF SMALL SIGNAL AMPLIFIER STAGES AND DIRECT COUPLED CIRCUITS.

BC107, 8, 9 are complementary to BC177, 8, 9
 BC167, 8, 9 are complementary to BC257, 8, 9
 BC207, 8, 9 are complementary to BC204, 5, 6
 BC237, 8, 9 are complementary to BC307, 8, 9
 BC317, 8, 9 are complementary to BC320, 1, 2

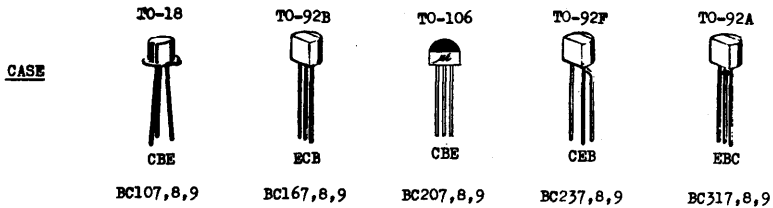

ABSOLUTE MAXIMUM RATINGS

TYPE	V _{CEO} (V)	V _{CES} (V)	V _{CE0} (V)	V _{EB0} (V)	I _{C(DC)} (mA)	P _{tot} (mW) *	T _j , T _{stg}
BC107	50	50	45	6	100	300	-55 to 175°C
BC108	30	30	20	5	100	300	
BC109	30	30	20	5	100	300	
BC167	50	50	45	6	100	300	-55 to 150°C
BC168	30	30	20	5	100	300	
BC169	30	30	20	5	100	300	
BC207	50		45	5	100	300	-55 to 125°C
BC208	25		25	5	100	300	
BC209	25		25	5	100	300	
BC237	50	50	45	6	100	300	-55 to 150°C
BC238	30	30	20	5	100	300	
BC239	30	30	20	5	100	300	
BC317	50		45	6	150	310	-55 to 150°C
BC318	45		30	5	150	310	
BC319	30		20	5	150	310	

* Total Power Dissipation @ T_A = 25°C

BC107,8,9 BC167,8,9 BC207,8,9 BC237,8,9 BC317,8,9

ELECTRICAL CHARACTERISTICS ($T_A=25^{\circ}\text{C}$ unless otherwise noted)

PARAMETER	SYMBOL	MIN	TYP	MAX	UNIT	TEST CONDITIONS		
Collector-Base Breakdown Voltage	$V_{V_{CB0}}$	↑ Note 1 ↓			V	$I_C=10\mu\text{A}$ $I_E=0$		
Collector-Emitter Breakdown Voltage	$V_{V_{CE0}}$ *				V	$I_C=2\text{mA}$ $I_B=0$		
Emitter-Base Breakdown Voltage	$V_{V_{EB0}}$				V	$I_E=1\mu\text{A}$ $I_C=0$		
Collector Cutoff Current BC107, 108, 109 BC167, 168, 169 BC237, 238, 239	I_{CES} } only			15	nA	$V_{CE}=V_{CES}$ $V_{BE}=0$		
					4	μA	$V_{CE}=V_{CES}$ $V_{BE}=0$ $T_A=125^{\circ}\text{C}$	
Collector Cutoff Current BC207 only	I_{CBO}			15	nA	$V_{CB}=40\text{V}$ $I_E=0$		
				15	μA	$V_{CB}=40\text{V}$ $I_E=0$ $T_A=65^{\circ}\text{C}$		
BC208, 209 only	I_{CBO}			15	nA	$V_{CB}=20\text{V}$ $I_E=0$		
				15	μA	$V_{CB}=20\text{V}$ $I_E=0$ $T_A=65^{\circ}\text{C}$		
BC317, 318, 319 only	I_{CBO}			30	nA	$V_{CB}=20\text{V}$ $I_E=0$		
				15	μA	$V_{CB}=20\text{V}$ $I_E=0$ $T_A=100^{\circ}\text{C}$		
Collector-Emitter Saturation Voltage BC107, 108, 109 BC167, 168, 169 BC207, 208, 209 BC237, 238, 239	$V_{CE(sat)}$ * } only		0.07	0.25	V	$I_C=10\text{mA}$ $I_B=0.5\text{mA}$		
				0.22	0.6	V	$I_C=100\text{mA}$ $I_B=5\text{mA}$	
BC317, 318, 319 only	$V_{CE(sat)}$ *		0.07	0.2	V	$I_C=10\text{mA}$ $I_B=0.5\text{mA}$		
			0.2	0.5	V	$I_C=100\text{mA}$ $I_B=5\text{mA}$		
Base-Emitter Saturation Voltage BC107, 108, 109 BC167, 168, 169 BC237, 238, 239	$V_{BE(sat)}$ * } only		0.7	0.83	V	$I_C=10\text{mA}$ $I_B=0.5\text{mA}$		
				0.9	1.05	V	$I_C=100\text{mA}$ $I_B=5\text{mA}$	
Base-Emitter Voltage All types BC317, 318, 319 only	V_{BE} *		0.55	0.63	0.7	V	$I_C=2\text{mA}$ $V_{CE}=5\text{V}$	
				0.68	0.77	V	$I_C=10\text{mA}$ $V_{CE}=5\text{V}$	
Current Gain-Bandwidth Product BC107, 108, 109 BC167, 168, 169 BC237, 238, 239	f_T } only		150	250		MHz	$I_C=10\text{mA}$ $V_{CE}=5\text{V}$	
Collector-Base Capacitance BC107, 108, 109 BC167, 168, 169 BC207, 208, 209 BC237, 238, 239 BC317, 318, 319	C_{ob}		3.2	6.0		pF	$V_{CB}=10\text{V}$ $I_E=0$ $f=1\text{MHz}$	
				2.7	4.5		pF	
				2.7	6.0		pF	
				2.7	4.5		pF	
				2.7	4.0		pF	
Noise Figure BC107, 108 BC167, 168 BC207, 208 BC237, 238 BC317, 318	NF		2	10		dB	$I_C=0.2\text{mA}$ $V_{CE}=5\text{V}$ $R_G=2\text{K}\Omega$ $f=1\text{kHz}$ $\Delta f=200\text{Hz}$	
				2	10		dB	
				2	10		dB	
				2	10		dB	
				2	6		dB	

* Pulse Test : Pulse Width=0.3ms, Duty Cycle=1%

Note 1 : *equal to the value of absolute maximum ratings.

BC107,8,9 BC167,8,9 BC207,8,9 BC237,8,9 BC317,8,9

PARAMETER	SYMBOL	MIN	TYP	MAX	UNIT	TEST CONDITIONS
Noise Figure BC109 BC169 BC209 BC239 BC319 } only	NF	1.5	4	dB	dB	$I_C=0.2mA$ $V_{CE}=5V$ $R_G=2K\Omega$ $f=1kHz$ $\Delta f=200Hz$
						$I_C=0.2mA$ $V_{CE}=5V$ $R_G=2K\Omega$ $f=30Hz-15KHz$

D.C. CURRENT GAIN (HFE) @ $V_{CE}=5V$ $T_A=25^\circ C$

at I_C (Pulsed)	BC107, 167, 207, 237, 317 BC108, 168, 208, 238, 318	BC107, 167, 207, 237, 317 BC108, 168, 208, 238, 318 BC109, 169, 209, 239, 319	BC108, 168, 208, 238, 318 BC109, 169, 209, 239, 319						
	HFE GROUP A			HFE GROUP B			HFE GROUP C		
	MIN	TYP	MAX	MIN	TYP	MAX	MIN	TYP	MAX
0.01mA	40	90		40	170		100	290	
2mA	110	170	220	200	300	450	420	520	800
100mA		100			160			270	

h-PARAMETERS @ $I_C=2mA$ $V_{CE}=5V$ $f=1kHz$ $T_A=25^\circ C$ (Note 2)

h - PARAMETER	SYMBOL	HFE GROUP A			HFE GROUP B			HFE GROUP C			UNIT
		MIN	TYP	MAX	MIN	TYP	MAX	MIN	TYP	MAX	
Input Impedance	h_{ie}	1.6	2.7	4.5	3.2	4.5	8.5	6	8.7	15	$K\Omega$
Voltage Feedback Ratio	h_{re}	1.5			2			3			$\times 10^{-4}$
Small Signal Current Gain	h_{fe}	125	190	260	240	330	500	450	580	900	
Output Admittance	h_{oe}	18			30			60			μS

TYPICAL CHARACTERISTICS AT $T_A=25^\circ C$ (Pulse Test)

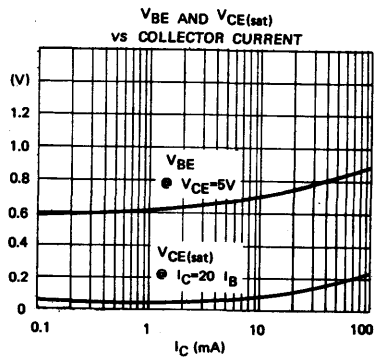
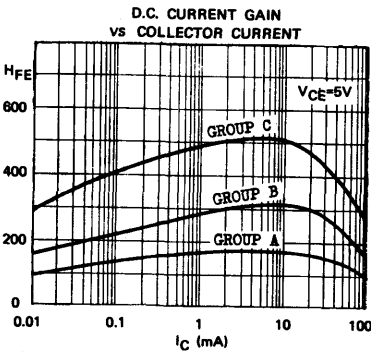

Note 2 : This table is not applicable to BC207,8,9.

BC107,8,9 BC167,8,9 BC207,8,9 BC237,8,9 BC317,8,9

TYPICAL CHARACTERISTICS ($T_A=25^\circ\text{C}$ UNLESS OTHERWISE SPECIFIED)

COMMON EMITTER
OUTPUT CHARACTERISTICS

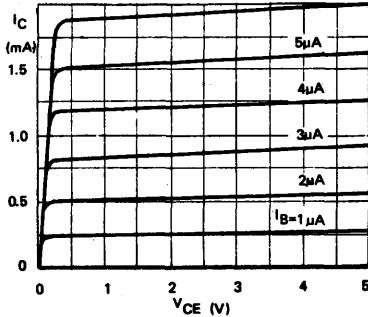

CURRENT GAIN - BANDWIDTH PRODUCT
VS COLLECTOR CURRENT

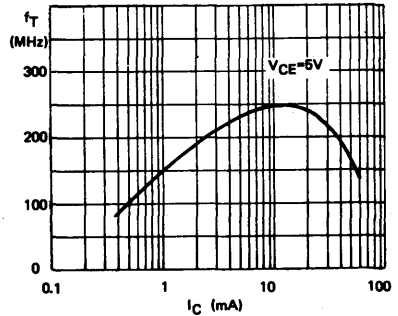

COLLECTOR CUTOFF CURRENT
VS AMBIENT TEMPERATURE

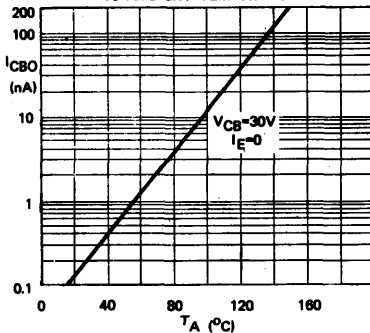

h-PARAMETERS (NORMALIZED)
VS COLLECTOR CURRENT

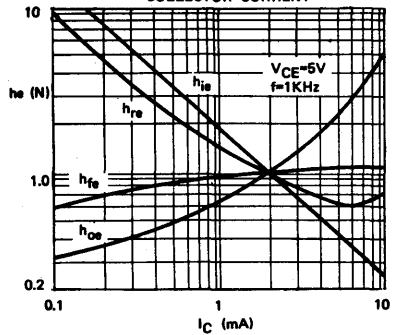

COLLECTOR-BASE CAPACITANCE
VS COLLECTOR-BASE VOLTAGE

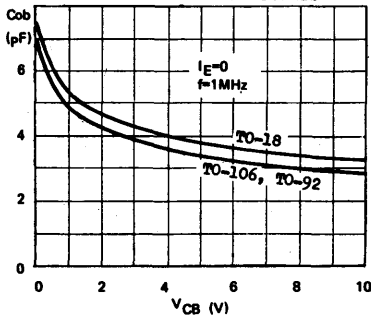

BROAD BAND NOISE FIGURE
VS COLLECTOR CURRENT

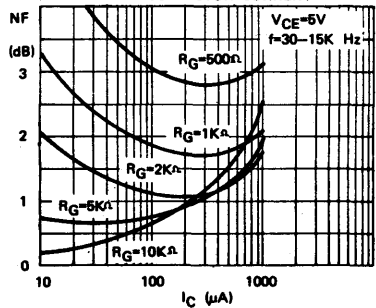

BC140 BC141

NPN SILICON AF MEDIUM POWER AMPLIFIERS & SWITCHES

THE BC140, BC141 ARE NPN SILICON PLANAR EPITAXIAL TRANSISTORS RECOMMENDED FOR AF DRIVERS AND OUTPUTS, AS WELL AS FOR SWITCHING APPLICATIONS UP TO 1 AMPERE. THE BC140, BC141 ARE COMPLEMENTARY TO THE PNP TYPE BC160, BC161 RESPECTIVELY.

CASE TO-39



C E B

ABSOLUTE MAXIMUM RATINGS

	BC140	BC141
Collector-Emitter Voltage ($V_{CE=0}$)	80V	100V
Collector-Emitter Voltage ($I_B=0$)	40V	60V
Emitter-Base Voltage	7V	7V
Collector Current	1A	
Total Power Dissipation (@ $T_C \leq 45^\circ\text{C}$)	3.7W	
(@ $T_A \leq 45^\circ\text{C}$)	650mW	
Operating Junction & Storage Temperature	-55 to 175°C	
	T_j, T_{stg}	

ELECTRICAL CHARACTERISTICS ($T_A=25^\circ\text{C}$ unless otherwise noted)

PARAMETER	SYMBOL	BC140		BC141		UNIT	TEST CONDITIONS		
		MIN	TYP MAX	MIN	TYP MAX				
Collector-Emitter Breakdown Voltage	BV_{CES}	80		100		V	$I_C=0.1\text{mA}$ $V_{BE}=0$		
Collector-Emitter Breakdown Voltage	LV_{CEO}^*	40		60		V	$I_C=50\text{mA}$ $I_B=0$		
Emitter-Base Breakdown Voltage	BV_{EBO}	7		7		V	$I_E=0.1\text{mA}$ $I_C=0$		
Collector Cutoff Current	I_{CES}		100		100	nA	$V_{CES}=60\text{V}$		
			100		100	μA	$V_{CES}=60\text{V}$ $T_A=150^\circ\text{C}$		
Collector-Emitter Saturation Voltage	$V_{CE(sat)}^*$		1		1	V	$I_C=1\text{A}$ $I_B=0.1\text{A}$		
Base-Emitter Voltage	V_{BE}^*		1.8		1.8	V	$I_C=1\text{A}$ $V_{CE}=1\text{V}$		
D.C. Current Gain	h_{FE}^*		40	250	40	250		$I_C=100\text{mA}$ $V_{CE}=1\text{V}$	
			Group 6	40	100	40			100
			Group 10	63	160	63			160
			Group 16	100	250	100			250
hFE Matched Pair Ratio	$\frac{h_{FE} 1}{h_{FE} 2}^*$		1.41		1.41		$I_C=100\text{mA}$ $V_{CE}=1\text{V}$		
Current Gain-Bandwidth Product	f_T	50	150	50	150	MHz	$I_C=50\text{mA}$ $V_{CE}=10\text{V}$		
Collector-Base Capacitance	C_{ob}	10	25	10	25	pF	$V_{CB}=10\text{V}$ $I_E=0$		
								$f=1\text{MHz}$	
Emitter-Base Capacitance	C_{ib}	80		80		pF	$V_{EB}=0.5\text{V}$ $I_C=0$		
								$f=1\text{MHz}$	
Turn-On Time	t_{on}		250		250	nS	$I_C=100\text{mA}$ $I_{B1}=5\text{mA}$		
Turn-Off Time	t_{off}		850		850	nS	$I_C=100\text{mA}$		
							$I_{B1}=I_{B2}=5\text{mA}$		

* Pulse Test : Pulse Width=0.3ms, Duty Cycle=1%

SWITCHING TIME TEST CIRCUIT (ton, toff)

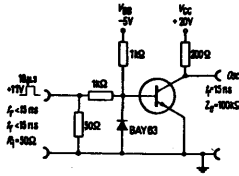

TYPICAL CHARACTERISTICS

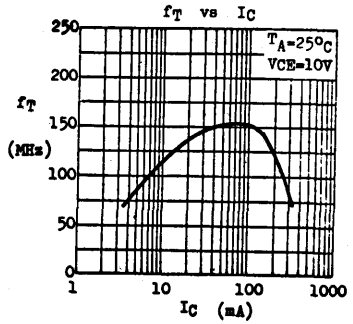
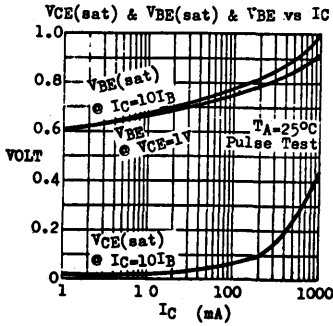
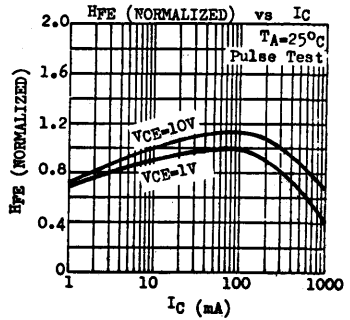
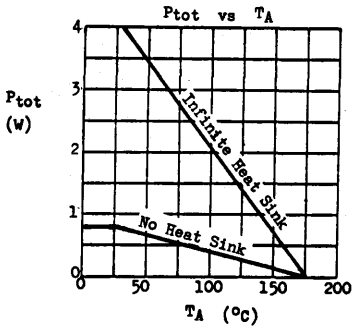

MINIATURE NPN AF LOW NOISE
SILICON PLANAR EPITAXIAL TRANSISTOR

GENERAL DESCRIPTION

The BC 146 is a NPN silicon planar epitaxial transistor in miniature plastic package designed for hearing aids, watches, paging systems and other equipment where small size is of paramount importance. The BC 146 is complementary to PNP BC 200.

MECHANICAL OUTLINE

MT-42

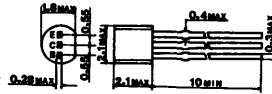

ALL DIMENSIONS IN mm

ABSOLUTE MAXIMUM RATINGS

Collector-Base Voltage
Collector-Emitter Voltage
Emitter-Base Voltage
Collector Current
Total Power Dissipation at $T_A \leq 45^\circ\text{C}$
Junction Temperature
Storage Temperature Range

V_{CBO}	20V
V_{CEO}	20V
V_{EBO}	4V
I_C	50mA
P_{tot}	50mW
T_j	125°C
T_{stg}	-65°C to +125°C

THERMAL RESISTANCE

Junction to Ambient

θ_{ja}	1.6°C/mW
---------------	----------

ELECTRICAL CHARACTERISTICS AT $T_A = 25^\circ\text{C}$

PARAMETER	SYMBOL	BC 146R			BC 146Y			BC 146G			UNIT	TEST CONDITIONS
		MIN	TYP	MAX	MIN	TYP	MAX	MIN	TYP	MAX		
Collector-Base Cutoff Current	I_{CBO}			100			100			100	nA	$V_{CE} = 20V$ $I_E = 0$
Collector-Emitter Knee Voltage	V_{CEK}			200			200			200	mV	$I_C = 2mA$ $I_B = \text{value for which } I_C = 2.2mA \text{ and } V_{CE} = 1V$
Base-Emitter Voltage	V_{BE}			570			570			570	mV	$V_{CE} = 0.5V$ $I_C = 0.2mA$
Base-Emitter Voltage	V_{BE}			630			630			630	mV	$V_{CE} = 1V$ $I_C = 2mA$
DC Current Gain	H_{FE}	80	120	200	140	220	350	280	380	550		$V_{CE} = 0.5V$ $I_C = 0.2mA$
DC Current Gain	H_{FE}	100			140			280				$V_{CE} = 1V$ $I_C = 2mA$
Noise Figure	NF			1.5			1.5			4	1.5	dB $R_g = 2K\Omega$ $f = 30Hz - 15KHz$
Transition Frequency	f_T			80			110			150	MHz	$V_{CE} = 5V$ $I_C = 2mA$
Collector Capacitance	C_{cb}			2.5			2.5			2.5	pF	$V_{CE} = 5V$ $I_E = 0$ $f = 1MHz$

TYPICAL h-PARAMETERS AT $V_{CE} = 0.5V$, $I_C = 0.2mA$, $f = 1KHz$

PARAMETER	SYMBOL	BC 146R	BC 146Y	BC146G	UNIT
Input Impedance	h_{ie}	20	30	45	$K\Omega$
Reverse Voltage Transfer Ratio	h_{re}	15	25	40	$\times 10^{-4}$
Small Signal Current Gain	h_{fe}	130	240	400	
Output Admittance	h_{oe}	15	20	35	$\mu\Omega$

TYPICAL ELECTRICAL CHARACTERISTICS AT $T_A = 25^\circ\text{C}$

DC CURRENT GAIN VERSUS COLLECTOR CURRENT

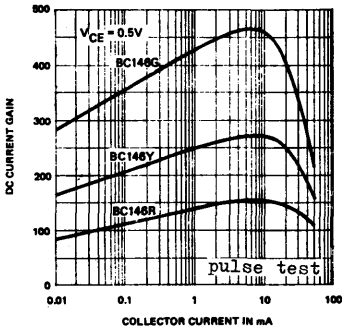

BASE-EMITTER VOLTAGE VERSUS COLLECTOR CURRENT

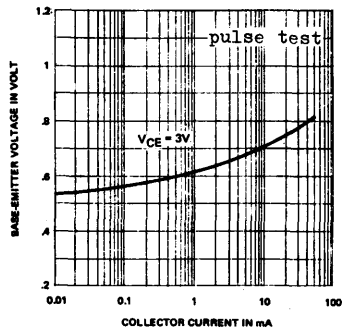

COLLECTOR-EMITTER SATURATION VOLTAGE VERSUS COLLECTOR CURRENT

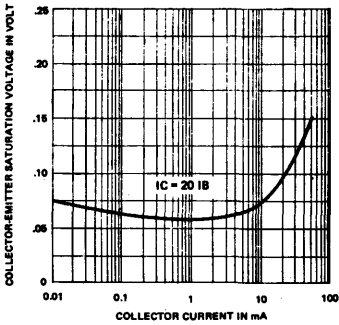

WIDE BAND NOISE FIGURE

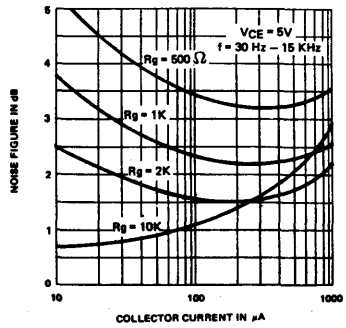

BC160 BC161

PNP SILICON AF MEDIUM POWER AMPLIFIERS & SWITCHES

THE BC160, BC161 ARE PNP SILICON PLANAR EPITAXIAL TRANSISTORS RECOMMENDED FOR AF DRIVERS AND OUTPUTS, AS WELL AS FOR SWITCHING APPLICATIONS UP TO 1 AMPERE. THE BC160, BC161 ARE COMPLEMENTARY TO THE NPN TYPE BC140, BC141 RESPECTIVELY.

CASE TO-39



C E B

ABSOLUTE MAXIMUM RATINGS

	BC160	BC161
Collector-Emitter Voltage ($V_{BE}=0$)	40V	60V
Collector-Emitter Voltage ($I_B=0$)	40V	60V
Emitter-Base Voltage	5V	5V
Collector Current		1A
Total Power Dissipation ($\theta T_C < 45^\circ\text{C}$)		3.7W
($\theta T_A < 45^\circ\text{C}$)		650mW
Operating Junction & Storage Temperature		-55 to 175°C

-V _{CE}	
-V _{CEO}	
-V _{EB0}	
-I _C	
P _{tot}	
T _j , T _{stg}	

ELECTRICAL CHARACTERISTICS ($T_A=25^\circ\text{C}$ unless otherwise noted)

PARAMETER	SYMBOL	BC160		BC161		UNIT	TEST CONDITIONS
		MIN	TYP MAX	MIN	TYP MAX		
Collector-Emitter Breakdown Voltage	-V _{CE}	40		60		V	-I _C =0.1mA V _{BE} =0
Collector-Emitter Breakdown Voltage	-V _{CEO} *	40		60		V	-I _C =50mA I _B =0
Emitter-Base Breakdown Voltage	-V _{EB0}	5		5		V	-I _E =0.1mA I _C =0
Collector Cutoff Current	-I _{CE}		100		100	nA	V _{CE} =V _{CE}
			100		100	μA	V _{CE} =V _{CE} T _A =150°C
Collector-Emitter Saturation Voltage	-V _{CE(sat)} *		1		1	V	-I _C =1A -I _B =0.1A
Base-Emitter Voltage	-V _{BE} *		1.7		1.7	V	-I _C =1A -V _{CE} =1V
D.C. Current Gain	h _{FE} *	40	250	40	250		-I _C =100mA -V _{CE} =1V
		40	100	40	100		
		63	160	63	160		
		100	250	100	250		
h _{FE} Matched Pair Ratio	h _{FE 1} *		1.41		1.41		-I _C =100mA -V _{CE} =1V
Current Gain-Bandwidth Product	f _T	50	140	50	140	MHz	-I _C =50mA -V _{CE} =10V
Collector-Base Capacitance	C _{ob}	18	30	18	30	pF	-V _{CB} =10V I _E =0
							f=1MHz
Emitter-Base Capacitance	C _{ib}		180		180	pF	-V _{EB} =0.5V I _C =0
							f=1MHz
Turn-On Time	t _{on}		500		500	nS	-I _C =100mA -I _B =5mA
Turn-Off Time	t _{off}		650		650	nS	-I _C =100mA
							-I _B =-I _{B2} =5mA

* Pulse Test ; Pulse Width=0.3ms, Duty Cycle=1%

SWITCHING TIME TEST CIRCUIT (t_{on} , t_{off})

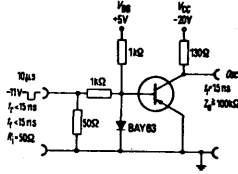

TYPICAL CHARACTERISTICS

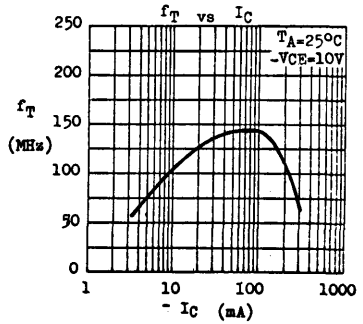
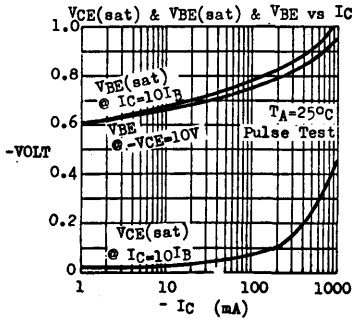
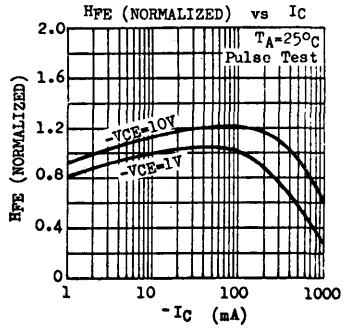
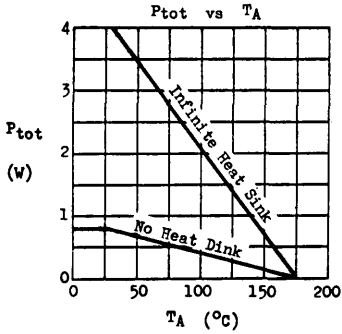

BC177,8,9 BC204,5,6 BC257,8,9 BC307,8,9 BC320,1,2

PNP SILICON AF SMALL SIGNAL TRANSISTORS

THE ABOVE TYPES ARE PNP SILICON PLANAR EPITAXIAL TRANSISTORS FOR USE IN AF SMALL SIGNAL AMPLIFIER STAGES AND DIRECT COUPLED CIRCUITS.

BC177, 8, 9 are complementary to BC107, 8, 9
 BC204, 5, 6 are complementary to BC207, 8, 9
 BC257, 8, 9 are complementary to BC167, 8, 9
 BC307, 8, 9 are complementary to BC237, 8, 9
 BC320, 1, 2 are complementary to BC317, 8, 9

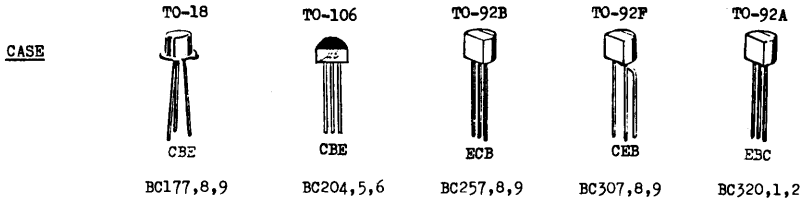

ABSOLUTE MAXIMUM RATINGS

TYPE	-V _{CB0} (V)	-V _{CES} (V)	-V _{CE0} (V)	-V _{EB0} (V)	-I _C (DC) (mA)	P _{tot} * (mW)	T _j , T _{stg}
BC177	50	50	45	5	100	300	-55 to 175°C
BC178	30	30	25	5	100	300	
BC179	25	25	20	5	100	300	
BC204	50		45	5	100	300	-55 to 125°C
BC205	25		20	5	100	300	
BC206	25		20	5	100	300	
BC257	50	50	45	5	100	300	-55 to 150°C
BC258	30	30	25	5	100	300	
BC259	25	25	20	5	100	300	
BC307	50	50	45	5	100	300	-55 to 150°C
BC308	30	30	25	5	100	300	
BC309	25	25	20	5	100	300	
BC320	50		45	6	150	310	-55 to 150°C
BC321	45		30	5	150	310	
BC322	30		20	5	150	310	

* Total Power Dissipation @ T_A ≤ 25°C

BC177,8,9 BC204,5,6 BC257,8,9 BC307,8,9 BC320,1,2

ELECTRICAL CHARACTERISTICS (TA=25°C unless otherwise noted)

PARAMETER	SYMBOL	MIN	TYP	MAX	UNIT	TEST CONDITIONS	
Collector-Base Breakdown Voltage	-BV _{CBO}	Note 1			V	-I _C =10μA I _E =0	
Collector-Emitter Breakdown Voltage	-LV _{CBO} *				V	-I _C =2mA I _B =0	
Emitter-Base Breakdown Voltage	-BV _{EBO}				V	-I _E =1μA I _C =0	
Collector Cutoff Current	-I _{CES}			15	nA	V _{CE} =V _{CES} V _{BE} =0	
BC177, 178, 179 } only				4	μA	V _{CE} =V _{CES} V _{BE} =0	
BC257, 258, 259 } only						T _A =125°C	
Collector Cutoff Current	-I _{CBO}			50	nA	-V _{CB} =45V I _E =0	
BC204 only				3	μA	-V _{CB} =45V I _E =0 T _A =65°C	
	-I _{CBO}			50	nA	-V _{CB} =20V I _E =0	
BC205, 206 only				3	μA	-V _{CB} =20V I _E =0 T _A =65°C	
	-I _{CBO}			30	nA	-V _{CB} =20V I _E =0	
BC320, 321, 322 only				15	μA	-V _{CB} =20V I _E =0 T _A =100°C	
Collector-Emitter Saturation Voltage	-V _{CE(sat)} *		0.1	0.3	V	-I _C =10mA -I _B =0.5mA	
All types				0.25		V	-I _C =100mA -I _B =5mA
Collector-Emitter Knee Voltage	-V _{CEK}		0.3	0.6	V	-I _C =10mA, I _B =value at which -I _C =11mA -V _{CE} =1V	
BC177, 178, 179 } only							
Base-Emitter Saturation Voltage	-V _{BE(sat)} *		0.72		V	-I _C =10mA -I _B =0.5mA	
All types				0.92		V	-I _C =100mA -I _B =5mA
Base-Emitter Voltage	-V _{BE} *	0.6	0.65	0.75	V	-I _C =2mA -V _{CE} =5V	
All types							
BC320, 321, 322 only	-V _{BE} *		0.7	0.77	V	-I _C =10mA -V _{CE} =5V	
Current Gain-Bandwidth Product	f _T		180		MHz	-I _C =10mA -V _{CE} =5V	
Collector-Base Capacitance	C _{ob}		3.6	7	pF	-V _{CB} =10V I _E =0	
BC177, 178, 179				3.2		pF	f=1MHz
BC204, 205, 206				3.2	6	pF	
BC257, 258, 259				3.2	6	pF	
BC307, 308, 309				3.2	6	pF	
BC320, 321, 322				3.2	4	pF	
Noise Figure	NF		2	10	dB	-I _C =0.2mA -V _{CE} =5V	
BC177, 178				2	10	dB	R _G =2KΩ f=1kHz
BC204, 205				2	10	dB	Δf=200Hz
BC257, 258				2	10	dB	
BC307, 308				2	10	dB	
BC320, 321				2	6	dB	

* Pulse Test : Pulse Width=0.3ms, Duty Cycle=1%

Note 1 : equal to the value of absolute maximum ratings.

BC177,8,9 BC204,5,6 BC257,8,9 BC307,8,9 BC320,1,2

PARAMETER	SYMBOL	MIN	TYP	MAX	UNIT	TEST CONDITIONS
Noise Figure BC179 BC206 BC259 BC309 BC322 } only	NF	1.2	4		dB	$-I_C=0.2mA$ $-V_{CE}=5V$ $R_C=2K\Omega$ $f=1kHz$ $\Delta f=200Hz$
		1.2	4		dB	$-I_C=0.2mA$ $-V_{CE}=5V$ $R_C=2K\Omega$ $f=30Hz-15KHz$

D.C. CURRENT GAIN (h_{FE}) @ $-V_{CE}=5V$ $T_A=25^\circ C$

at $-I_C$ (Pulsed)	BC177, 204, 257, 307, 320 BC178, 205, 258, 308, 321			BC177, 204, 257, 307, 320 BC178, 205, 258, 308, 321			BC177, 204, 257, 307, 320 BC178, 205, 258, 308, 321			BC178, 205, 258, 308, 321 BC179, 206, 259, 309, 322		
	HFE GROUP VI			HFE GROUP A			HFE GROUP B			HFE GROUP C		
	MIN	TYP	MAX	MIN	TYP	MAX	MIN	TYP	MAX	MIN	TYP	MAX
0.01mA	70			110			200			330		
2mA	70	110	140	110	170	220	200	300	450	420	520	800
100mA	60			80			140			240		

h - PARAMETERS @ $-I_C=2mA$ $-V_{CE}=5V$ $f=1kHz$ $T_A=25^\circ C$ (Note 2)

h - PARAMETER	SYMBOL	HFE GROUP VI MIN TYP MAX	HFE GROUP A MIN TYP MAX	HFE GROUP B MIN TYP MAX	HFE GROUP C MIN TYP MAX	UNIT
Input Impedance	h_{ie}	1.4	2.7	4.5	8.7	$K\Omega$
Voltage Feedback Ratio	h_{re}	2.5	3	3.5	4	$\times 10^{-4}$
Small Signal Current Gain	h_{fe}	75 110 150	125 190 260	240 330 500	450 580 900	
Output Admittance	h_{oe}	20	25	35	60	μS

TYPICAL CHARACTERISTICS AT $T_A=25^\circ C$ (Pulse Test)

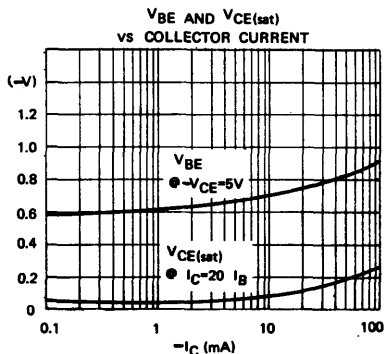
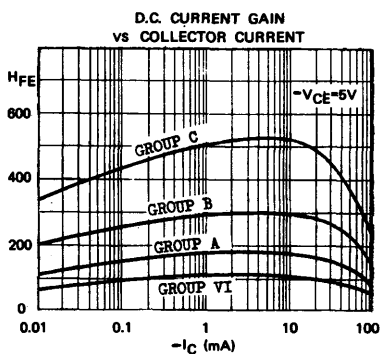

Note 2 : This table is not applicable to BC204,5,6.

BC177,8,9 BC204,5,6 BC257,8,9 BC307,8,9 BC320,1,2

TYPICAL CHARACTERISTICS ($T_A=25^\circ\text{C}$ UNLESS OTHERWISE SPECIFIED)

COMMON EMITTER
OUTPUT CHARACTERISTICS

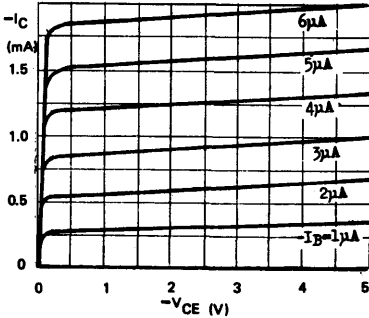

CURRENT GAIN - BANDWIDTH PRODUCT
VS COLLECTOR CURRENT

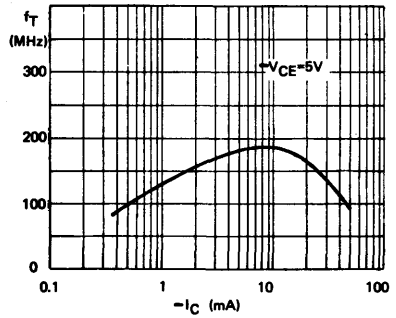

COLLECTOR CUTOFF CURRENT
VS AMBIENT TEMPERATURE

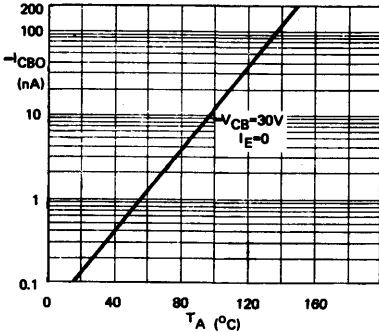

h-PARAMETERS (NORMALIZED)
VS COLLECTOR CURRENT

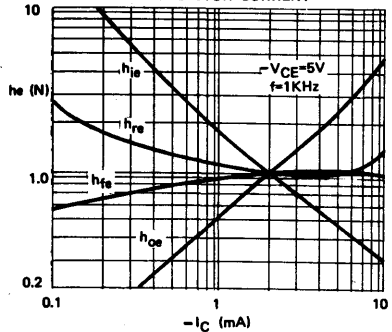

COLLECTOR-BASE CAPACITANCE
VS COLLECTOR-BASE VOLTAGE

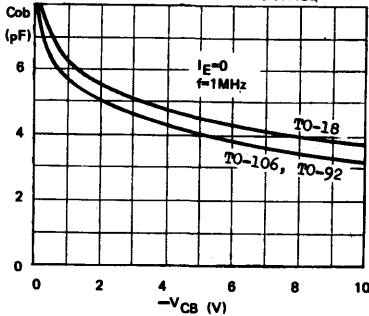

BROAD BAND NOISE FIGURE
VS COLLECTOR CURRENT

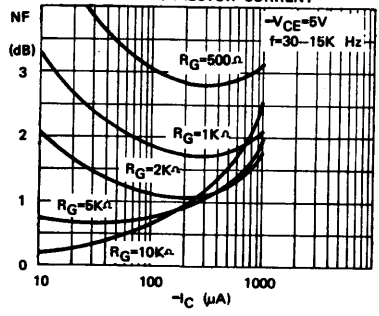

BC182 BC212

COMPLEMENTARY

SILICON AF SMALL SIGNAL AMPLIFIERS & DRIVERS

THE BC182(NPN) AND BC212(PNP) ARE COMPLEMENTARY SILICON PLANAR EPITAXIAL TRANSISTORS FOR USE IN AF SMALL SIGNAL AMPLIFIERS AND DRIVERS, AS WELL AS FOR LOW POWER UNIVERSAL APPLICATIONS. BOTH TYPES FEATURE GOOD LINEARITY OF DC CURRENT GAIN.

CASE TO-92F



ABSOLUTE MAXIMUM RATINGS

For n-p-n devices, voltage and current values are negative.

Collector-Base Voltage	V _{CB0}
Collector-Emitter Voltage	V _{CE0}
Emitter-Base Voltage	V _{EB0}
Collector Current	I _C
Total Power Dissipation (T _A < 25°C)	P _{tot}
Operating Junction & Storage Temperature	T _j , T _{stg}

<u>BC182(NPN)</u>	<u>BC212(PNP)</u>
-------------------	-------------------

60V	60V
50V	50V
6V	5V
	200mA
	300mW
derate 2.4mW/°C above 25°C	
-55 to 150°C	

ELECTRICAL CHARACTERISTICS (T_A = 25°C unless otherwise noted)

PARAMETER	SYMBOL	BC182(NPN)			BC212(PNP)			UNIT	TEST CONDITIONS
		MIN	TYP	MAX	MIN	TYP	MAX		
Collector-Base Breakdown Voltage	V _{CB0}	60			60			V	I _C = 0.01mA I _B = 0
Collector-Emitter Breakdown Voltage	V _{CE0} *	50			50			V	I _C = 2mA I _B = 0
Emitter-Base Breakdown Voltage	V _{EB0}	6			5			V	I _E = 0.01mA I _C = 0
Collector Cutoff Current	I _{CB0}		15			15		nA	V _{CB} = 50V I _B = 0
Emitter Cutoff Current	I _{EB0}		15			15		nA	V _{EB} = 4V I _C = 0
Collector-Emitter Saturation Voltage	V _{CE(sat)} *	0.05	0.25		0.05			V	I _C = 10mA I _B = 0.5mA
Base-Emitter Saturation Voltage	V _{BE(sat)} *	0.85	1.2		0.85	1.1		V	I _C = 100mA I _B = 5mA
Base-Emitter Voltage	V _{BE} *	0.55	0.62	0.7	0.55	0.62	0.7	V	I _C = 2mA V _{CE} = 5V
D.C. Current Gain	h _{FE} *	40			40				I _C = 10mA V _{CE} = 5V
		120		460	60		220		I _C = 2mA V _{CE} = 5V
		80					110		I _C = 100mA V _{CE} = 5V
Small Signal Current Gain	h _{fe}								I _C = 2mA V _{CE} = 5V
Group A		125		260	100		300		f = 1kHz
Group B		240		500	200		400		
Current Gain-Bandwidth Product	f _T	150	220		200	300		MHz	I _C = 10mA V _{CE} = 5V

BC182 BC212

PARAMETER	SYMBOL	BC182(NPN)			BC212(PNP)			UNIT	TEST CONDITIONS
		MIN	TYP	MAX	MIN	TYP	MAX		
Collector-Base Capacitance	Cob		3.7	5		5		pF	V _{CB} =10V I _E =0 f=1MHz
Noise Figure	NF		2	10		1.5	10	dB	I _C =0.2mA V _{CE} =5V R _C =2K Ω f=1kHz Δ f=200Hz

* Pulse Test : Pulse Width=0.5mS, Duty Cycle=1%

TYPICAL CHARACTERISTICS (T_A=25°C unless otherwise noted)

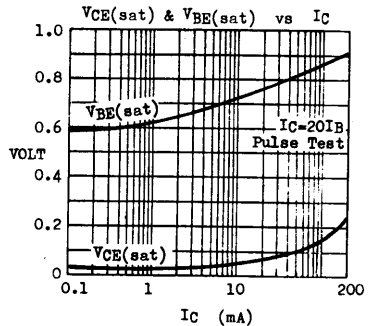
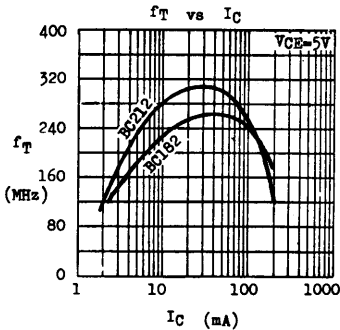
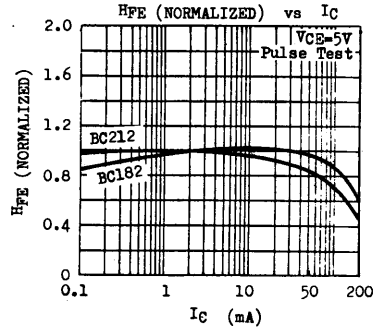
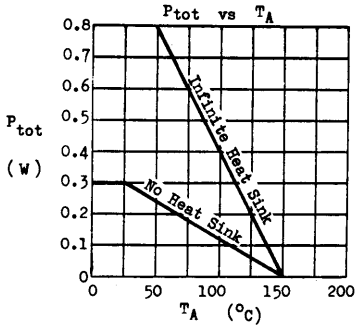

2.78.6500B.0610B

MINIATURE PNP AF LOW NOISE
SILICON PLANAR EPITAXIAL TRANSISTOR

GENERAL DESCRIPTION

The BC 200 is a PNP silicon planar epitaxial transistor in miniature plastic package designed for hearing aids, watches, paging systems and other equipment where small size is of paramount importance. The BC 200 is complementary to NPN BC 146.

MECHANICAL OUTLINE
MT-42

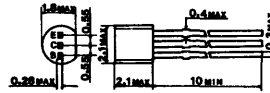

ALL DIMENSIONS IN mm

ABSOLUTE MAXIMUM RATINGS

Collector-Base Voltage
Collector-Emitter Voltage
Emitter-Base Voltage
Collector Current
Total Power Dissipation at $T_A \leq 45^\circ\text{C}$
Junction Temperature
Storage Temperature Range

$-V_{CB0}$	20V
$-V_{CEO}$	20V
$-V_{EBO}$	5V
$-I_C$	50mA
P_{tot}	50mW
T_J	125°C
T_{stg}	-65°C to +125°C

THERMAL RESISTANCE

Junction to Ambient

θ_{je}	1.6°C/mW
---------------	----------

ELECTRICAL CHARACTERISTICS AT $T_A = 25^\circ\text{C}$

PARAMETER	SYMBOL	BC 200R			BC 200Y			BC 200G			UNIT	TEST CONDITIONS
		MIN	TYP	MAX	MIN	TYP	MAX	MIN	TYP	MAX		
Collector Cutoff Current	$-I_{CBO}$		100		100		100		100		nA	$-V_{CB}=20V$ $I_E=0$
Collector Cutoff Current	$-I_{CBO}$		1		1		1		1		μA	$-V_{CB}=20V$ $I_E=0$ $T_J=125^\circ\text{C}$
Collector-Emitter Knee Voltage	$-V_{CEK}$		200		200		200		200		mV	$-I_C=2mA$ for which $-I_C=2mA$ and $-V_{CE}=1V$
Base-Emitter Voltage	$-V_{BE}$		580		580		580		580		mV	$-V_{CE}=0.5V$ $-I_C=0.2mA$
Base-Emitter Voltage	$-V_{BE}$		550		550		550		550		mV	$-V_{CE}=1V$ $-I_C=2mA$
D.C. Current Gain	h_{FE}	50	75	105	85	140	200	165	260	400		$-V_{CE}=0.5V$ $-I_C=0.2mA$
D.C. Current Gain	h_{FE}	60			100			175				$-V_{CE}=1V$ $-I_C=2mA$
Noise Figure	NF		1.5		1.5	4	1.5				dB	$-V_{CE}=5V$ $-I_C=0.2mA$ $R_g=2K\Omega$ $f=30Hz$ to 18KHz
Transition Frequency	f_T		80		110		150		150		MHz	$-V_{CE}=5V$ $-I_C=2mA$
Collector Capacitance	C_{cb}		4.5		4.5		4.5		4.5		pF	$-V_{CB}=5V$ $I_E=0$ $f=1MHz$

TYPICAL h-PARAMETERS AT $-V_{CE}=0.5V$, $-I_C=0.2mA$, $f=1KHz$

PARAMETER	SYMBOL	BC 200R	BC 200Y	BC 200G	UNIT
Input Impedance	h_{ie}	12	15	20	K Ω
Reverse Voltage Transfer Ratio	h_{re}	13	25	40	$\times 10^{-4}$
Small Signal Current Gain	h_{fe}	80	160	270	
Output Admittance	h_{oe}	13	18	33	μu

TYPICAL ELECTRICAL CHARACTERISTICS AT $T_A = 25^\circ\text{C}$

DC CURRENT GAIN VERSUS COLLECTOR CURRENT

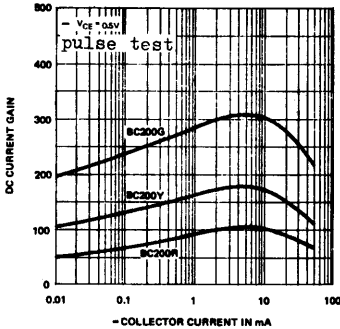

BASE-EMITTER VOLTAGE VERSUS COLLECTOR CURRENT

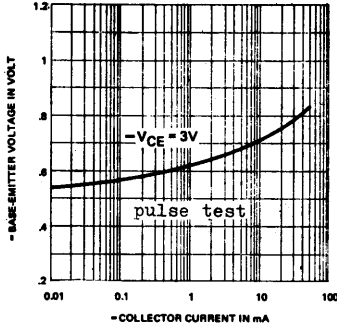

COLLECTOR-EMITTER SATURATION VOLTAGE VERSUS COLLECTOR CURRENT

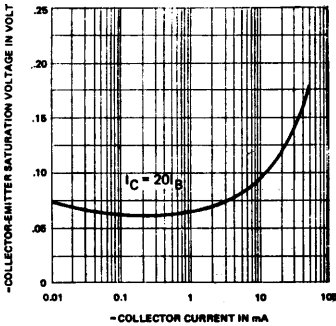

WIDE BAND NOISE FIGURE

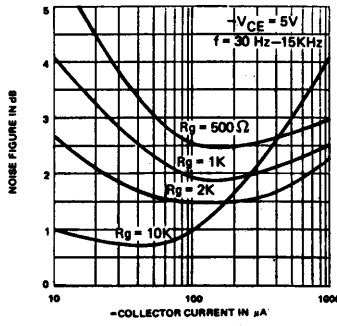

BC286 BC287

COMPLEMENTARY

SILICON AF MEDIUM POWER AMPLIFIERS & SWITCHES

THE BC286(NPN) AND BC287(PNP) ARE COMPLEMENTARY SILICON PLANAR EPITAXIAL TRANSISTORS FOR AF DRIVERS AND OUTPUTS, AS WELL AS FOR SWITCHING APPLICATIONS UP TO 1 AMPERE.

CASE TO-39



ABSOLUTE MAXIMUM RATINGS

For p-n-p device, voltage and current values are negative.

		BC286(NPN)	BC287(PNP)
Collector-Base Voltage	V _{CB0}	70V	60V
Collector-Emitter Voltage	V _{CE0}	60V	60V
Emitter-Base Voltage	V _{EB0}	5V	5V
Collector Current	I _C		1A
Total Power Dissipation (• T _C ≤ 25°C)	P _{tot}		4W
	(• T _A ≤ 25°C)		0.8W
Operating Junction & Storage Temperature	T _J , T _{stg}		-55 to 200°C

ELECTRICAL CHARACTERISTICS (T_A=25°C unless otherwise noted)

PARAMETER	SYMBOL	BC286(NPN)		BC287(PNP)		UNIT	TEST CONDITIONS
		MIN	TYP MAX	MIN	TYP MAX		
Collector-Base Breakdown Voltage	BV _{CB0}	70		60		V	I _C =0.1mA I _B =0
Collector-Emitter Breakdown Voltage	LV _{CE0} *	60		60		V	I _C =10mA I _B =0
Emitter-Base Breakdown Voltage	BVE _{B0}	5		5		V	I _E =0.1mA I _C =0
Collector Cutoff Current	IC _{B0}		20		50	nA	V _{CB} =30V I _B =0
Collector-Emitter Saturation Voltage	V _{CE(sat)} *	0.4	1	0.45	1	V	I _C =1A I _B =0.1A
Base-Emitter Voltage	V _{BE} *	0.87		0.9		V	I _C =500mA V _{CE} =2V
D.C. Current Gain	h _{FE} *	20	180	20	200		I _C =500mA V _{CE} =2V
Current Gain-Bandwidth Product	f _T	150		140		MHz	I _C =50mA V _{CE} =5V
Collector-Base Capacitance	C _{ob}	11		18		pF	V _{CB} =10V I _B =0 f=1MHz

* Pulse Test : Pulse Width=0.3ms, Duty Cycle=1%

TYPICAL CHARACTERISTICS

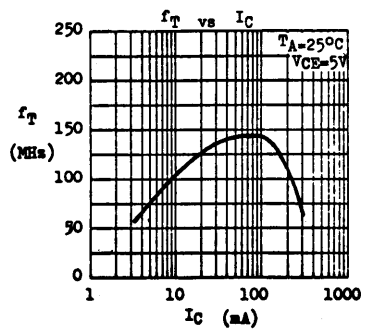
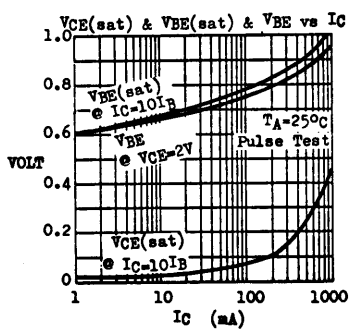
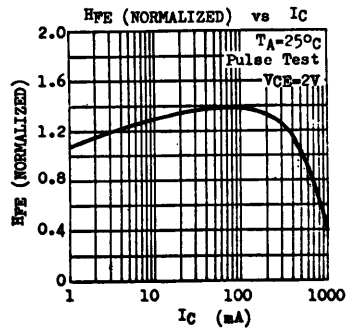
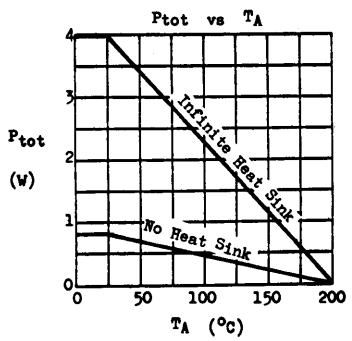

BC300 BC301 BC302

NPN SILICON AF MEDIUM POWER AMPLIFIERS & SWITCHES

THE BC300, BC301, BC302 ARE NPN SILICON PLANAR EPITAXIAL TRANSISTORS RECOMMENDED FOR AF DRIVERS AND OUTPUTS, AS WELL AS FOR SWITCHING APPLICATIONS UP TO 1 AMPERE. THEY ARE COMPLEMENTARY TO THE PNP TYPE BC303 AND BC304.

CASE TO-39



C E B

ABSOLUTE MAXIMUM RATINGS

		BC300	BC301	BC302
Collector-Base Voltage	VCBO	120V	90V	60V
Collector-Emitter Voltage	VCEO	80V	60V	45V
Emitter-Base Voltage	VEBO		7V	
Collector Current	IC		1A	
Total Power Dissipation (Tc ≤ 25°C) (TA ≤ 25°C)	Ptot		6W	850mW
Operating Junction & Storage Temperature	Tj, Tstg		-55 to 175°C	

ELECTRICAL CHARACTERISTICS (TA=25°C unless otherwise noted)

PARAMETER	SYMBOL	MIN	TYP	MAX	UNIT	TEST CONDITIONS
Collector-Emitter Breakdown Voltage	LVCEO *					IC=100mA IB=0
BC300		80			V	
BC301		60			V	
BC302		45			V	
Collector-Emitter Breakdown Voltage	LVCEV *					IC=100mA VEB=1.5V
BC300 only		120			V	
BC301 only		90			V	
Collector Cutoff Current	ICBO			20	nA	VCB=60V IE=0
Emitter Cutoff Current	IEBO			20	nA	VEB=7V IC=0
Collector-Emitter Saturation Voltage	VCE(sat)*		0.1	0.5	V	IC=150mA IB=15mA
Base-Emitter Voltage	VBE *		0.78		V	IC=150mA VCE=10V
D.C. Current Gain	HFE *	20				IC=0.1mA VCE=10V
		40		240		IC=150mA VCE=10V
		20				IC=500mA VCE=10V
D.C. Current Gain	HFE *	40	80			IC=150mA VCE=10V
Group 4		70	140			
Group 5		120	240			
Group 6						
Current Gain-Bandwidth Product	fT		120		MHz	IC=10mA VCE=10V
Collector-Base Capacitance	Cob		10		pF	VCB=10V IE=0 f=1MHz

* Pulse Test : Pulse Width=0.5ms, Duty Cycle=1%

BC300 BC301 BC302

TYPICAL CHARACTERISTICS

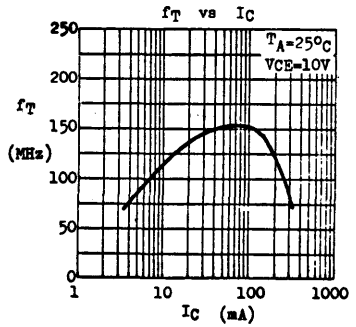
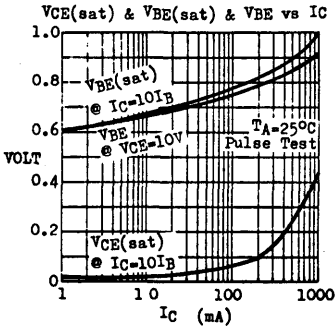
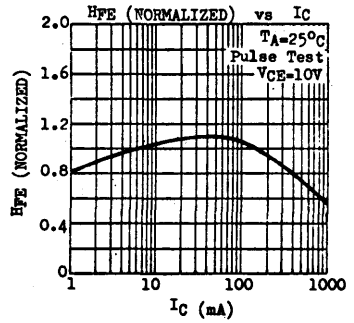
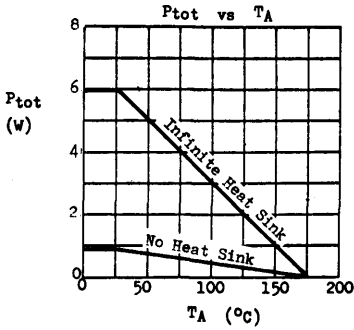

BC303 BC304

PNP SILICON AF MEDIUM POWER AMPLIFIERS & SWITCHES

THE BC303, BC304 ARE PNP SILICON PLANAR EPITAXIAL TRANSISTORS RECOMMENDED FOR AF DRIVERS & OUTPUTS, AS WELL AS FOR SWITCHING APPLICATIONS UP TO 1 AMPERE. THEY ARE COMPLEMENTARY TO THE NPN TYPE BC300, BC301, BC302.

CASE TO-39



ABSOLUTE MAXIMUM RATINGS

	BC303	BC304
Collector-Base Voltage	-V _{CB0} 85V	60V
Collector-Emitter Voltage	-V _{CE0} 60V	45V
Emitter-Base Voltage	-V _{EB0} 7V	7V
Collector Current	-I _C 1A	
Total Power Dissipation (T _C < 25°C) (T _A < 25°C)	P _{tot} 6W	850mW
Operating Junction & Storage Temperature	T _j , T _{stg} -55 to 175°C	

ELECTRICAL CHARACTERISTICS (T_A=25°C unless otherwise noted)

PARAMETER	SYMBOL	MIN	TYP	MAX	UNIT	TEST CONDITIONS
Collector-Emitter Breakdown Voltage BC303 BC304	-V _{CEO} *	60			V	-I _C =100mA I _B =0
		45			V	
Collector-Emitter Breakdown Voltage BC303 only	-V _{CEV}	85			V	-I _C =100mA -V _{EB} =1.5V
Collector Cutoff Current	-I _{CB0}			20	nA	-V _{CB} =60V I _E =0
Emitter Cutoff Current	-I _{EB0}			20	nA	-V _{EB} =5V I _C =0
Collector-Emitter Saturation Voltage	-V _{CE(sat)} *	0.1	0.65		V	-I _C =150mA -I _B =15mA
Base-Emitter Voltage	-V _{BE} *	0.78			V	-I _C =150mA -V _{CE} =10V
D.C. Current Gain	h _{FE} *	20				-I _C =0.1mA -V _{CE} =10V
		40		240		-I _C =150mA -V _{CE} =10V
		20				-I _C =500mA -V _{CE} =10V
						-I _C =150mA -V _{CE} =10V
D.C. Current Gain	h _{FE} *	40		80		-I _C =150mA -V _{CE} =10V
		70		140		
		120		240		
Current Gain-Bandwidth Product	f _T		100		MHz	-I _C =10mA -V _{CE} =10V
Collector-Base Capacitance	C _{ob}		17		pF	-V _{CB} =10V I _E =0 f=1MHz

* Pulse Test : Pulse Width=0.3ms, Duty Cycle=1%

TYPICAL CHARACTERISTICS

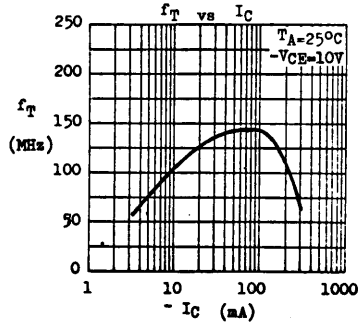
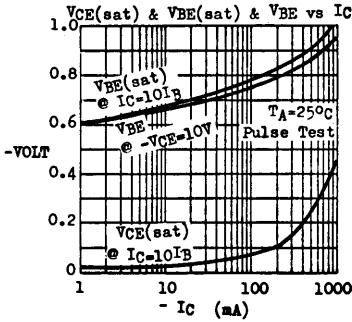
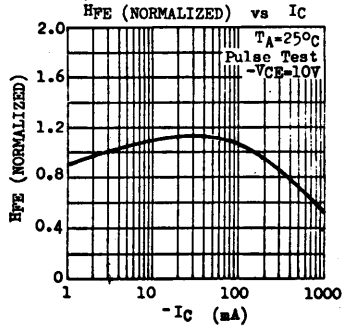
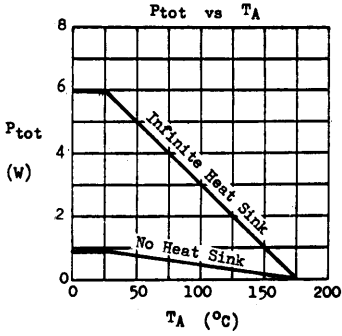

BC327 BC328

PNP SILICON AF MEDIUM POWER TRANSISTORS

THE BC327, BC328 ARE PNP SILICON PLANAR EPITAXIAL TRANSISTORS FOR USE IN AF DRIVER AND OUTPUT STAGES, AS WELL AS FOR UNIVERSAL APPLICATIONS. THE BC327, BC328 ARE COMPLEMENTARY TO THE NPN TYPE BC337, BC338 RESPECTIVELY.

CASE TO-92F



ABSOLUTE MAXIMUM RATINGS

		BC327	BC328
Collector-Emitter Voltage ($V_{BE}=0$)	$-V_{CES}$	50V	30V
Collector-Emitter Voltage ($I_B=0$)	$-V_{CEO}$	45V	25V
Emitter-Base Voltage	$-V_{EB0}$		5V
Collector Current	$-I_C$		0.8A
Collector Peak Current ($t < 10\mu S$)	$-I_{CM}$		1.5A
Total Power Dissipation (@ $T_C < 25^\circ C$)	P_{tot}		1.4W
(@ $T_A < 25^\circ C$)			625mW
Operating Junction & Storage Temperature	T_j, T_{stg}	-55 to $150^\circ C$	

THERMAL RESISTANCE

Junction to Case	θ_{jc}	90°C/W	max.
Junction to Ambient	θ_{ja}	200°C/W	max.

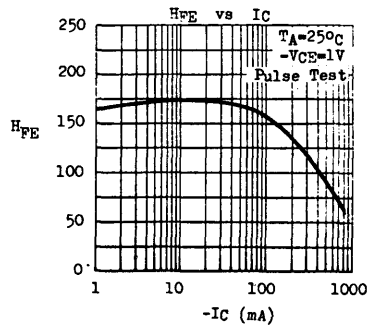
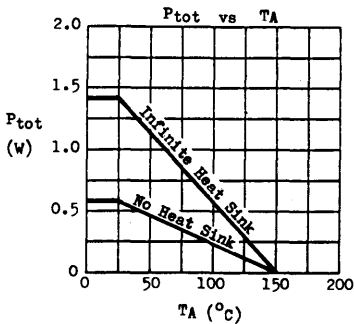

BC327 BC328

ELECTRICAL CHARACTERISTICS (T_A=25°C unless otherwise noted)

PARAMETER	SYMBOL	BC327		BC328		UNIT	TEST CONDITIONS
		MIN	TYP MAX	MIN	TYP MAX		
Collector-Emitter Breakdown Voltage	-BV _{CE} S	50		30		V	-I _C =0.1mA V _{BE} =0
Collector-Emitter Breakdown Voltage	-LV _{CE} O *	45		25		V	-I _C =10mA I _B =0
Emitter-Base Breakdown Voltage	-BV _{EB} O	5		5		V	-I _E =0.1mA I _C =0
Collector Cutoff Current	-I _{CE} S		100		100	nA	-V _{CE} =45V -V _{CE} =25V
			10		10	μA	-V _{CE} =45V T _A =125°C -V _{CE} =25V T _A =125°C
Collector-Emitter Saturation Voltage	-V _{CE} (sat) *		0.7		0.7	V	-I _C =500mA -I _B =50mA
Base-Emitter Voltage	-V _{BE} *		1.2		1.2	V	-I _C =300mA -V _{CE} =1V
D.C. Current Gain	H _{FE} *	100	630	100	630		-I _C =100mA -V _{CE} =1V
	Group 16	100	250	100	250		
	Group 25	160	400	160	400		
	Group 40	250	630	250	630		
	All Groups	40		40			-I _C =300mA -V _{CE} =1V
H _{FE} Matched Pair Ratio	$\frac{H_{FE} 1}{H_{FE} 2}$ *		1.41		1.41		-I _C =100mA -V _{CE} =1V
Current Gain-Bandwidth Product	f _T		100		100	MHz	-I _C =10mA -V _{CE} =5V
Collector-Base Capacitance	C _{ob}		14		14	pF	-V _{CB} =10V I _B =0 f=1MHz

* Pulse Test : Pulse Width=0.3ms, Duty Cycle=1%

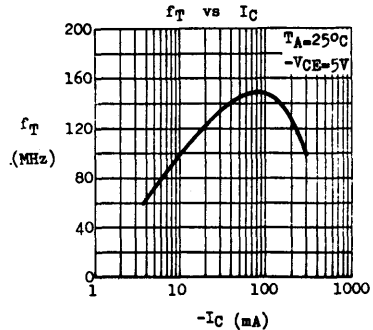
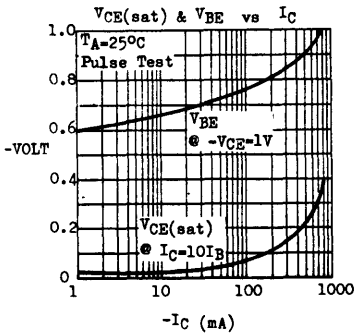

1.78.0830A

BC337 BC338

NPN SILICON AF MEDIUM POWER TRANSISTORS

THE BC337, BC338 ARE NPN SILICON PLANAR EPITAXIAL TRANSISTORS FOR USE IN AF DRIVER AND OUTPUT STAGES, AS WELL AS FOR UNIVERSAL APPLICATIONS. THE BC337, BC338 ARE COMPLEMENTARY TO THE PNP TYPE BC327, BC328 RESPECTIVELY.

CASE TO-92F



ABSOLUTE MAXIMUM RATINGS

Collector-Emitter Voltage ($V_{BE}=0$)
 Collector-Emitter Voltage ($I_B=0$)
 Emitter-Base Voltage
 Collector Current
 Collector Peak Current ($t < 10\mu\text{s}$)
 Total Power Dissipation ($\text{at } T_C < 25^\circ\text{C}$)
 ($\text{at } T_A < 25^\circ\text{C}$)
 Operating Junction & Storage Temperature

	BC337	BC338
V_{CES}	50V	30V
V_{CEO}	45V	25V
V_{EBO}	5V	
I_C	0.8A	
I_{CM}	1.5A	
P_{tot}	1.4W	
	625mW	
T_j, T_{stg}	-55 to 150°C	

THERMAL RESISTANCE

Junction to Case
 Junction to Ambient

θ_{jc}	90°C/W	max.
θ_{ja}	200°C/W	max.

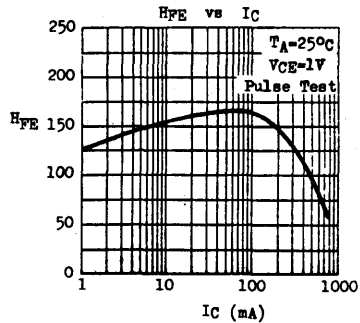
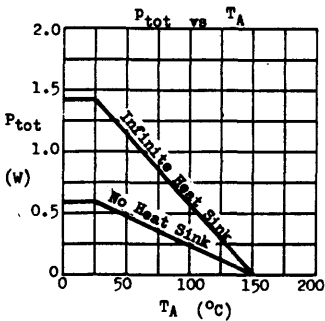

BC337 BC338

ELECTRICAL CHARACTERISTICS ($T_A=25^\circ\text{C}$ unless otherwise noted)

PARAMETER	SYMBOL	BC337			BC338			UNIT	TEST CONDITIONS
		MIN	TYP	MAX	MIN	TYP	MAX		
Collector-Emitter Breakdown Voltage	V_{VCEs}	50			30			V	$I_C=0.1\text{mA}$ $V_{BE}=0$
Collector-Emitter Breakdown Voltage	V_{VCE0} *	45			25			V	$I_C=10\text{mA}$ $I_B=0$
Emitter-Base Breakdown Voltage	V_{VEBO}	5			5			V	$I_E=0.1\text{mA}$ $I_C=0$
Collector Cutoff Current	I_{CES}			100			100	nA	$V_{CEs}=45\text{V}$
							10	nA	$V_{CEs}=25\text{V}$
							10	μA	$V_{CEs}=45\text{V}$ $T_A=125^\circ\text{C}$
							10	μA	$V_{CEs}=25\text{V}$ $T_A=125^\circ\text{C}$
Collector-Emitter Saturation Voltage	$V_{CE(sat)}$ *		0.7		0.7			V	$I_C=500\text{mA}$ $I_B=50\text{mA}$
Base-Emitter Voltage	V_{BE} *		1.2		1.2			V	$I_C=300\text{mA}$ $V_{CE}=1\text{V}$
D.C. Current Gain	H_{FE} *	Group 16	100	630	100	630			$I_C=100\text{mA}$ $V_{CE}=1\text{V}$
		Group 25	100	250	100	250			
		Group 40	160	400	160	400			
		All Groups	250	630	250	630			
H_{FE} Matched Pair Ratio	$\frac{H_{FE} 1}{H_{FE} 2}$ *		1.41		1.41				$I_C=100\text{mA}$ $V_{CE}=1\text{V}$
Current Gain-Bandwidth Product	f_T		100		100			MHz	$I_C=10\text{mA}$ $V_{CE}=5\text{V}$
Collector-Base Capacitance	C_{ob}		10		10			pF	$V_{CB}=10\text{V}$ $I_E=0$ $f=1\text{MHz}$

* Pulse Test : Pulse Width=0.3ms, Duty Cycle=1%

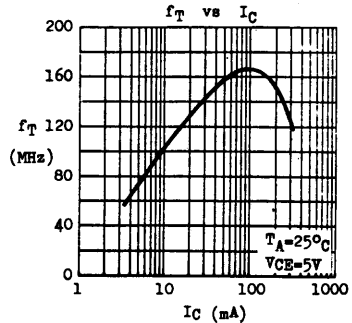
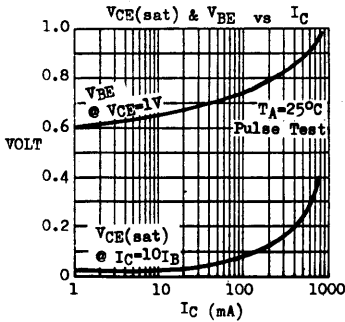

BC413 BC414 BC415 BC416

COMPLEMENTARY

SILICON AF LOW NOISE SMALL SIGNAL TRANSISTORS

THE BC413, BC414, BC415, BC416 ARE SILICON PLANAR EPITAXIAL TRANSISTORS FOR AF LOW NOISE PREAMPLIFIER APPLICATIONS. THE BC413, BC414 ARE NPN AND ARE COMPLEMENTARY TO THE PNP BC415, BC416 RESPECTIVELY.

CASE TO-92P



ABSOLUTE MAXIMUM RATINGS

For p-n-p devices, voltage and current values are negative

		BC413 (NPN)	BC414 (NPN)	BC415 (PNP)	BC416 (PNP)
Collector-Base Voltage	V _{CB0}	45V	50V	45V	50V
Collector-Emitter Voltage	V _{CE0}	30V	45V	35V	45V
Emitter-Base Voltage	V _{EB0}		5V		
Collector Current	I _C		100mA		
Total Power Dissipation @ T _A < 25°C	P _{tot}		300mW		
			derate 2.4mW/°C above 25°C		
Operating Junction & Storage Temperature	T _j , T _{stg}		-55 to 150°C		

ELECTRICAL CHARACTERISTICS (T_A=25°C unless otherwise noted)

PARAMETER	SYMBOL	MIN	TYP	MAX	UNIT	TEST CONDITIONS
Collector-Base Breakdown Voltage	BVCBO					I _C =10μA I _B =0
BC413		45			V	
BC414		50			V	
BC415		45			V	
BC416		50			V	
Collector-Emitter Breakdown Voltage	LVCEO					I _C =10mA (Pulsed) I _B =0
BC413		30			V	
BC414		45			V	
BC415		35			V	
BC416		45			V	
Emitter-Base Breakdown Voltage	BVEBO	5			V	I _B =10μA I _C =0
Collector Cutoff Current	ICBO		15		nA	V _{CB} =30V I _B =0
			5		μA	V _{CB} =30V I _B =0 T _A =150°C
Emitter Cutoff Current	IEBO		15		nA	V _{EB} =4V I _C =0
Collector-Emitter Saturation Voltage	V _{CE(sat)}	0.08	0.25		V	I _C =10mA I _B =0.5mA
		0.25	0.6		V	I _C =100mA I _B =5mA (Pulsed)

BC413 BC414 BC415 BC416

PARAMETER	SYMBOL	MIN	TYP	MAX	UNIT	TEST CONDITIONS
Collector-Emitter Knee Voltage	V_{CEK}	0.3	0.6		V	$I_C=10mA$, I_B =value at which $I_C=11mA$ $V_{CE}=1V$
Base-Emitter Saturation Voltage	$V_{BE(sat)}$	0.92			V	$I_C=100mA$ $I_B=5mA$ (Pulsed)
Base-Emitter Voltage	V_{BE}	0.55	0.64	0.75	V	$I_C=2mA$ $V_{CE}=5V$
			0.57		V	$I_C=0.1mA$ $V_{CE}=5V$
Current Gain-Bandwidth Product	f_T	200			MHz	$I_C=10mA$ $V_{CE}=5V$
Collector-Base Capacitance	C_{ob}				pF	$V_{CB}=10V$ $I_B=0$
BC413, BC414		2.7			pF	$f=1MHz$
BC415, BC416		3.2			pF	
Noise Figure	NF				dB	$I_C=0.2mA$ $V_{CE}=5V$
BC413, BC414		1.2	2.5		dB	$R_C=2K\Omega$ $f=30Hz-15KHz$
BC415, BC416		1.2	2.0		dB	
Flicker Noise Voltage Referred to Base	\bar{E}_n				μV	$I_C=0.2mA$ $V_{CE}=5V$
BC413, BC414			0.135		μV	$R_C=2K\Omega$ $f=10Hz-50Hz$
BC415, BC416			0.11		μV	

D.C. CURRENT GAIN (HFE) AT $V_{CE}=5V$ $T_A=25^\circ C$

I_C	BC415, BC416		BC413, BC414, BC415, BC416			BC413, BC414, BC415, BC416			
	HFE GROUP A		HFE GROUP B			HFE GROUP C			
	MIN	TYP	MAX	MIN	TYP	MAX	MIN	TYP	MAX
0.01mA	40	100		100	170		100	290	
2mA	120	170	220	180	300	460	380	520	800
100mA		100			160			270	

h - PARAMETERS AT $I_C=2mA$ $V_{CE}=5V$ $f=1kHz$ $T_A=25^\circ C$

h - PARAMETER	SYMBOL	HFE GROUP A			HFE GROUP B			HFE GROUP C			UNIT
		MIN	TYP	MAX	MIN	TYP	MAX	MIN	TYP	MAX	
Input Impedance	h_{ie}	1.6	2.7	4.5	3.2	4.5	8.5	6	8.7	15	$K\Omega$
Voltage Feedback Ratio	h_{re}		1.5			2			3		$\times 10^{-4}$
Small Signal Current Gain	h_{fe}	125	190	260	240	330	500	450	580	900	
Output Admittance	h_{oe}		18	30		30	60		60	110	μS

FLICKER NOISE MEASUREMENT

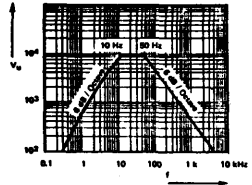
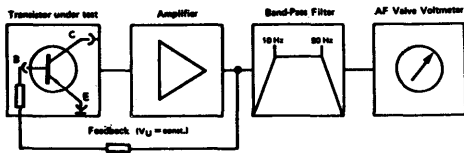

TYPICAL CHARACTERISTICS AT T_A=25°C (Pulse Test)

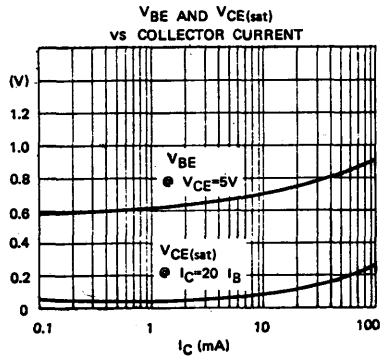
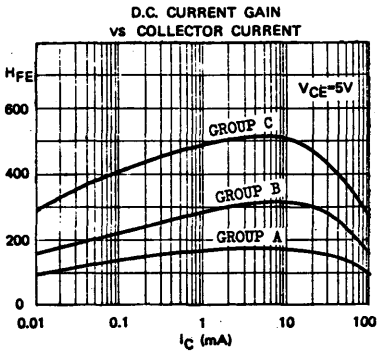

BC413 BC414 BC415 BC416

TYPICAL CHARACTERISTICS ($T_A=25^\circ\text{C}$ UNLESS OTHERWISE SPECIFIED)

COMMON EMITTER
OUTPUT CHARACTERISTICS

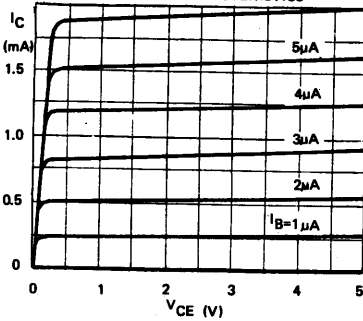

CURRENT GAIN - BANDWIDTH PRODUCT
VS COLLECTOR CURRENT

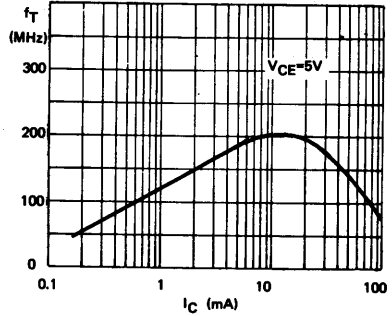

COLLECTOR CUTOFF CURRENT
VS AMBIENT TEMPERATURE

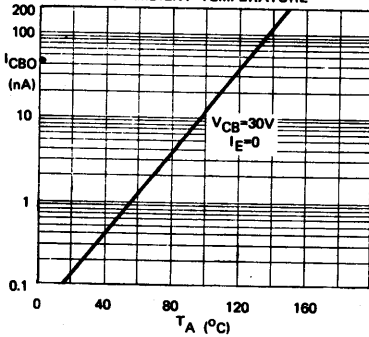

EQUIVALENT NOISE VOLTAGE AT BASE
VS COLLECTOR CURRENT

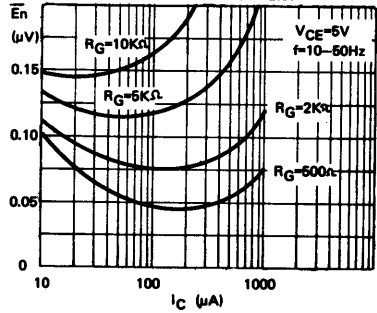

COLLECTOR-BASE CAPACITANCE
VS COLLECTOR-BASE VOLTAGE

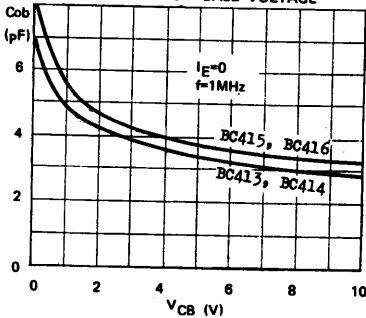

BROAD BAND NOISE FIGURE
VS COLLECTOR CURRENT

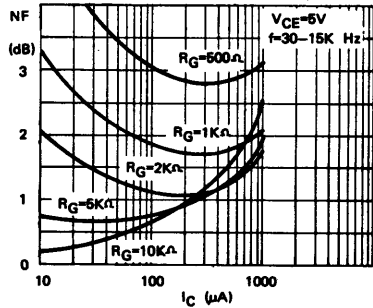

BC431 BC432

COMPLEMENTARY SILICON AF MEDIUM POWER TRANSISTORS

THE BC431 (NPN) AND BC432 (PNP) ARE COMPLEMENTARY SILICON PLANAR EPITAXIAL TRANSISTORS FOR USE IN AF DRIVER AND OUTPUT STAGES, AS WELL AS FOR UNIVERSAL APPLICATIONS.

CASE TO-92F



ABSOLUTE MAXIMUM RATINGS

For p-n-p devices, voltage and current values are negative

Collector-Emitter Voltage ($V_{BE}=0$)	V_{CES}	70V
Collector-Emitter Voltage ($I_B=0$)	V_{CEO}	60V
Emitter-Base Voltage	V_{EBO}	5V
Collector Current	I_C	0.8A
Collector Peak Current ($t \leq 10\text{ms}$)	I_{CM}	1.5A
Total Power Dissipation (@ $T_C \leq 25^\circ\text{C}$)	P_{tot}	1.4W
(@ $T_A \leq 25^\circ\text{C}$)		625mW
Operating Junction & Storage Temperature	T_j, T_{stg}	-55 to 150°C

THERMAL RESISTANCE

Junction to Case	θ_{jc}	90°C/W max.
Junction to Ambient	θ_{ja}	200°C/W max.

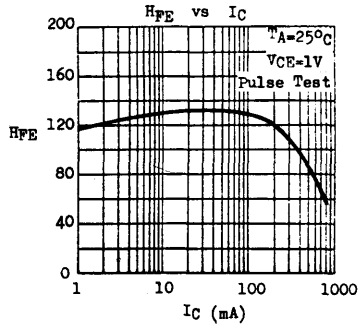
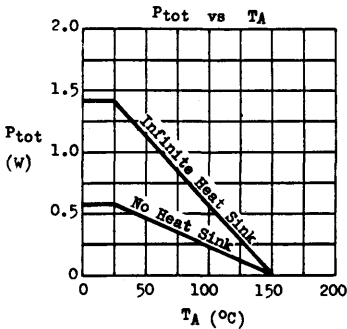

ELECTRICAL CHARACTERISTICS (TA=25°C unless otherwise noted)

PARAMETER	SYMBOL	MIN	TYP	MAX	UNIT	TEST CONDITIONS
Collector-Emitter Breakdown Voltage	V_{CES}	70			V	$I_C=0.1mA$ $V_{BE}=0$
Collector-Emitter Breakdown Voltage	V_{CE0}^*	60			V	$I_C=10mA$ $I_B=0$
Emitter-Base Breakdown Voltage	V_{EBO}	5			V	$I_C=0.1mA$ $I_C=0$
Collector Cutoff Current	I_{CES}			100	nA	$V_{CES}=60V$
				10	μA	$V_{CES}=60V$ $T_A=125^\circ C$
Collector-Emitter Saturation Voltage	$V_{CE(sat)}^*$		0.7		V	$I_C=500mA$ $I_B=50mA$
Base-Emitter Voltage	V_{BE}^*		1.2		V	$I_C=300mA$ $V_{CE}=1V$
D.C. Current Gain	H_{FE}^*	Group 10	63	250		$I_C=100mA$ $V_{CE}=1V$
			63	160		
			100	250		
			All Groups	40		
H_{FE} Matched Pair Ratio	$\frac{H_{FE} 1}{H_{FE} 2}^*$		1.41			$I_C=100mA$ $V_{CE}=1V$
Current Gain-Bandwidth Product	f_T		100		MHz	$I_C=10mA$ $V_{CE}=5V$
Collector-Base Capacitance	C_{ob}	BC431	12		pF	$V_{CB}=10V$ $I_B=0$
		BC432	17		pF	$f=1MHz$

* Pulse Test : Pulse Width=0.3ms, Duty Cycle=1%

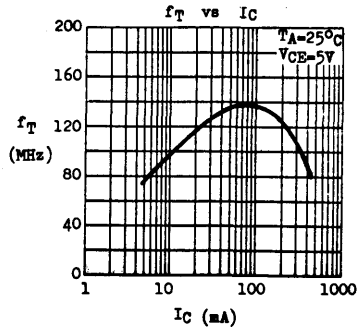
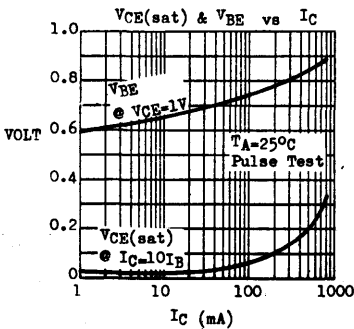

BC440 BC441 BC460 BC461

COMPLEMENTARY SILICON AF MEDIUM POWER AMPLIFIERS & SWITCHES

THE BC440, BC441, BC460, BC461 ARE SILICON PLANAR EPITAXIAL TRANSISTORS FOR AF DRIVERS AND OUTPUTS, AS WELL AS FOR SWITCHING APPLICATIONS UP TO 1 AMPERE. THE BC440, BC441 ARE NPN AND ARE COMPLEMENTARY TO THE PNP BC460, BC461 RESPECTIVELY.

CASE TO-39



ABSOLUTE MAXIMUM RATINGS For p-n-p device, voltage and current values are negative.

		BC440(NPN) BC460(PNP)	BC441(NPN) BC461(PNP)
Collector-Emitter Voltage ($R_{BE} \leq 100 \Omega$)	V _{CE}	50V	75V
Collector-Emitter Voltage ($I_B=0$)	V _{CEO}	40V	60V
Emitter-Base Voltage	V _{EB0}	5V	5V
Collector Current	I _C		1A
Collector Peak Current	I _{CM}		2A
Total Power Dissipation ($T_C \leq 25^\circ C, V_{CE} \leq 10V$) ($T_A \leq 25^\circ C$)	P _{tot}		10W 1W
Operating Junction & Storage Temperature	T _j , T _{stg}		-55 to 200°C

ELECTRICAL CHARACTERISTICS ($T_A=25^\circ C$ unless otherwise noted)

PARAMETER	SYMBOL	BC440 BC460		BC441 BC461		UNIT	TEST CONDITIONS
		MIN	MAX	MIN	MAX		
Collector-Emitter Breakdown Voltage	V _{CEO} *	40		60		V	I _C =100mA I _B =0
Emitter-Base Breakdown Voltage	V _{EB0}	5		5		V	I _E =0.1mA I _C =0
Collector Cutoff Current	I _{CBO}		100		100	nA	V _{CB} =40V I _E =0
Collector Cutoff Current	I _{CER}		10		10	μA	V _{CE} =50V R _{BE} =100Ω V _{CE} =70V R _{BE} =100Ω
Collector-Emitter Saturation Voltage	V _{CE(sat)} *		1		1	V	I _C =1A I _B =0.1A
Base-Emitter Saturation Voltage	V _{BE(sat)} *		1.5		1.5	V	I _C =1A I _B =0.1A
D.C. Current Gain	H _{FE} *	40	250	40	250	V	I _C =500mA V _{CE} =4V
		40	70	40	70		
		60	130	60	130		
		115	250	115	250		
		20					I _C =1A V _{CE} =2V
Current Gain-Bandwidth Product	f _T		50		50	MHz	I _C =50mA V _{CE} =4V
Collector-Base Capacitance	C _{ob}		25		25	pF	V _{CB} =10V I _E =0 f=1MHz

* Pulse Test : Pulse Width=0.3μS, Duty Cycle=1%

TYPICAL CHARACTERISTICS

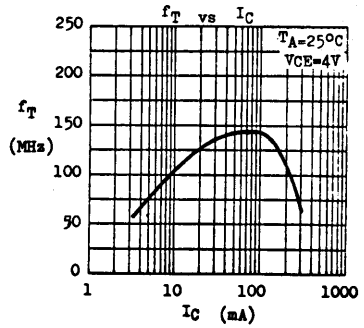
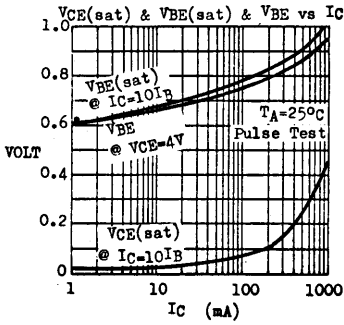
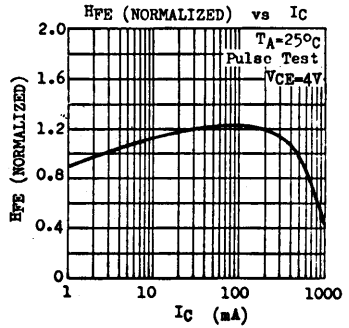
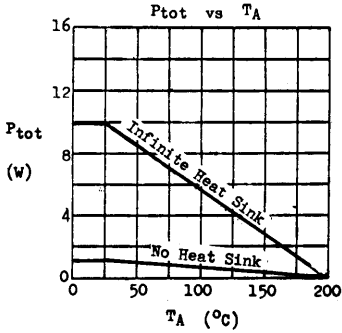

BC527 BC528

PNP SILICON AF MEDIUM POWER TRANSISTORS

THE BC527, BC528 ARE PNP SILICON PLANAR EPITAXIAL TRANSISTORS FOR USE IN AF DRIVER AND OUTPUT STAGES, AS WELL AS FOR UNIVERSAL APPLICATIONS. THE BC527, BC528 ARE COMPLEMENTARY TO THE NPN TYPE BC537, BC538 RESPECTIVELY.

CASE TO-92A



ABSOLUTE MAXIMUM RATINGS

		BC527	BC528
Collector-Base Voltage	$-V_{CBO}$	60V	80V
Collector-Emitter Voltage	$-V_{CEO}$	60V	80V
Emitter-Base Voltage	$-V_{EBO}$		6V
Collector Current	$-I_C$		1A
Collector Peak Current ($t \leq 10\mu s$)	$-I_{CM}$		1.5A
Total Power Dissipation (@ $T_C \leq 25^\circ C$) (@ $T_A \leq 25^\circ C$)	P_{tot}		1.5W 625mW
Operating Junction & Storage Temperature	T_j, T_{stg}		-55 to $150^\circ C$

THERMAL RESISTANCE

Junction to Case	θ_{jc}	83°C/W max.
Junction to Ambient	θ_{ja}	200°C/W max.

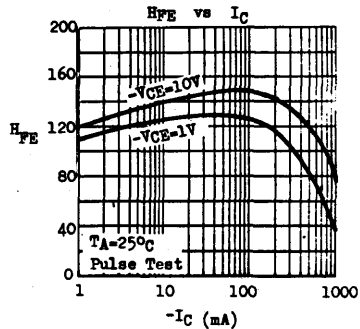
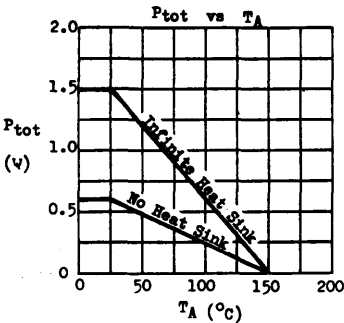

BC527 BC528

ELECTRICAL CHARACTERISTICS (TA=25°C unless otherwise noted)

PARAMETER	SYMBOL	BC527		BC528		UNIT	TEST CONDITIONS
		MIN	MAX	MIN	MAX		
Collector-Base Breakdown Voltage	$-BV_{CB0}$	60		80		V	$-I_C=0.1mA$ $I_B=0$
Collector-Emitter Breakdown Voltage	$-LV_{CE0}^*$	60		80		V	$-I_C=10mA$ $I_B=0$
Emitter-Base Breakdown Voltage	$-BV_{EB0}$	6		6		V	$-I_E=0.01mA$ $I_C=0$
Collector Cutoff Current	$-I_{CB0}$		100		100	nA	$-V_{CB}=40V$ $I_E=0$ $-V_{CB}=60V$ $I_E=0$
Emitter Cutoff Current	$-I_{EB0}$		100		100	nA	$-V_{EB}=4V$ $I_C=0$
Collector-Emitter Saturation Voltage	$-V_{CE(sat)}^*$		0.7		0.7	V	$-I_C=500mA$ $-I_B=50mA$ $-I_C=1A$ $-I_B=0.1A$
Base-Emitter Saturation Voltage	$-V_{BE(sat)}^*$		1.3		1.3	V	$-I_C=150mA$ $-I_B=15mA$
D.C. Current Gain	H_{FE}^*	40	400	40	400		$-I_C=100mA$ $-V_{CE}=1V$
Group 6		40	100	40	100		
Group 10		63	160	63	160		
Group 16		100	250	100	250		
Group 25		160	400	160	400		
All Groups	H_{FE}^*	50		50			$-I_C=10mA$ $-V_{CE}=10V$ $-I_C=150mA$ $-V_{CE}=10V$ $-I_C=500mA$ $-V_{CE}=10V$ $-I_C=1A$ $-V_{CE}=10V$
		50		50			
		50		50			
		15		15			
Current Gain-Bandwidth Product	f_T	100		100		MHz	$-I_C=50mA$ $-V_{CE}=10V$
Collector-Base Capacitance	C_{ob}		15		15	pF	$-V_{CB}=10V$ $I_E=0$ $f=1MHz$

* Pulse Test : Pulse Width=0.3ms, Duty Cycle=1%

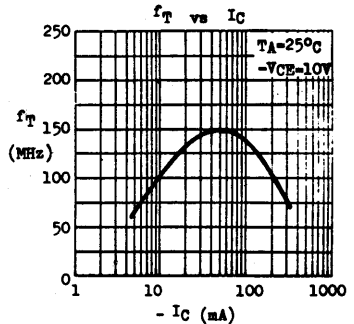
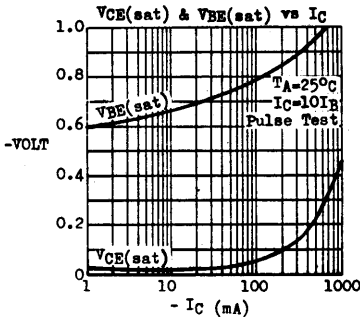

1.78.0810B

BC537 BC538

NPN SILICON AF MEDIUM POWER TRANSISTORS

THE BC537, BC538 ARE NPN SILICON PLANAR EPITAXIAL TRANSISTORS FOR USE IN AF DRIVER AND OUTPUT STAGES, AS WELL AS FOR UNIVERSAL APPLICATIONS. THE BC537, BC538 ARE COMPLEMENTARY TO THE PNP TYPE BC527, BC528 RESPECTIVELY.

CASE TO-92A



ABSOLUTE MAXIMUM RATINGS

		BC537	BC538
Collector-Base Voltage	V_{CBO}	60V	80V
Collector-Emitter Voltage	V_{CEO}	60V	80V
Emitter-Base Voltage	V_{EBO}	6V	
Collector Current	I_C	1A	
Collector Peak Current ($t \leq 10\mu S$)	I_{CM}	1.5A	
Total Power Dissipation ($\text{at } T_C \leq 25^\circ C$) ($\text{at } T_A \leq 25^\circ C$)	P_{tot}	1.5W	625mW
Operating Junction & Storage Temperature	T_j, T_{stg}	-55 to $150^\circ C$	

THERMAL RESISTANCE

Junction to Case	θ_{jc}	830°C/W max.
Junction to Ambient	θ_{ja}	2000°C/W max.

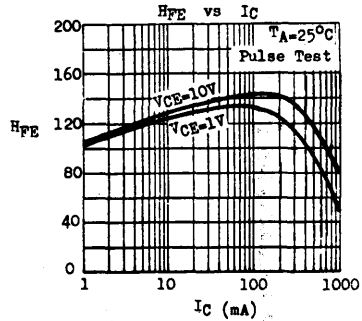
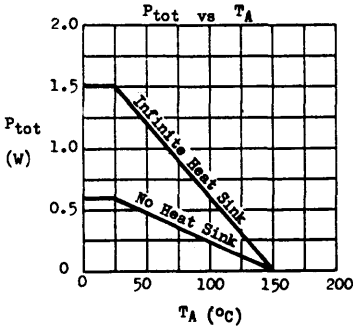

BC537 BC538

ELECTRICAL CHARACTERISTICS ($T_A=25^\circ\text{C}$ unless otherwise noted)

PARAMETER	SYMBOL	BC537		BC538		UNIT	TEST CONDITIONS
		MIN	MAX	MIN	MAX		
Collector-Base Breakdown Voltage	V_{VCBO}	60		80		V	$I_C=0.1\text{mA}$ $I_B=0$
Collector-Emitter Breakdown Voltage	V_{VCEO}^*	60		80		V	$I_C=10\text{mA}$ $I_B=0$
Emitter-Base Breakdown Voltage	V_{VEBO}	6		6		V	$I_E=0.01\text{mA}$ $I_C=0$
Collector Cutoff Current	I_{CBO}		100		100	nA	$V_{CB}=40\text{V}$ $I_E=0$ $V_{CB}=60\text{V}$ $I_E=0$
Emitter Cutoff Current	I_{EBO}		100		100	nA	$V_{EB}=4\text{V}$ $I_C=0$
Collector-Emitter Saturation Voltage	$V_{CE(sat)}^*$		0.7		0.7	V	$I_C=500\text{mA}$ $I_B=50\text{mA}$
			1.2		1.5	V	$I_C=1\text{A}$ $I_B=0.1\text{A}$
Base-Emitter Saturation Voltage	$V_{BE(sat)}^*$		1.3		1.3	V	$I_C=150\text{mA}$ $I_B=15\text{mA}$
D.C. Current Gain	H_{FE}^*		40	400	40	400	$I_C=100\text{mA}$ $V_{CE}=1\text{V}$
		Group 6	40	100	40	100	
		Group 10	63	160	63	160	
		Group 16	100	250	100	250	
		Group 25	160	400	160	400	
	All Groups	H_{FE}^*	50	50	50	50	$I_C=10\text{mA}$ $V_{CE}=10\text{V}$ $I_C=150\text{mA}$ $V_{CE}=10\text{V}$ $I_C=500\text{mA}$ $V_{CE}=10\text{V}$ $I_C=1\text{A}$ $V_{CE}=10\text{V}$
	50		50	50	50		
	50		50	50	50		
	15		15	15	15		
Current Gain-Bandwidth Product	f_T	100		100		MHz	$I_C=50\text{mA}$ $V_{CE}=10\text{V}$
Collector-Base Capacitance	C_{ob}		15		15	pF	$V_{CB}=10\text{V}$ $I_E=0$ $f=1\text{MHz}$

* Pulse Test : Pulse Width=0.3ms, Duty Cycle=1%

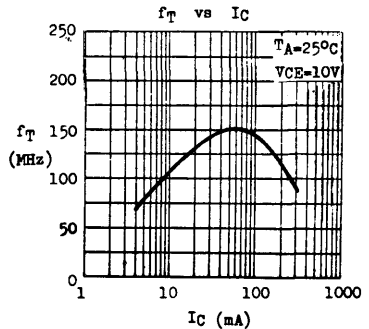
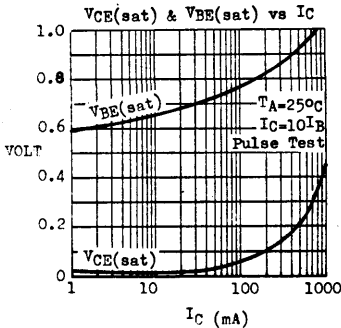

1.78.8100B

BC546 through BC550

NPN SILICON AF SMALL SIGNAL TRANSISTORS

THE BC546 THROUGH BC550 ARE NPN SILICON PLANAR EPITAXIAL TRANSISTORS FOR USE IN AF SMALL SIGNAL AMPLIFIER STAGES AND DIRECT COUPLED CIRCUITS. THEY ARE COMPLEMENTARY TO BC556 THROUGH BC560.

THE BC549, BC550 ARE CHARACTERIZED BY LOW NOISE FIGURE.

CASE TO-92P



CEB

ABSOLUTE MAXIMUM RATINGS

		BC546	BC547	BC548	BC549	BC550
Collector-Base Voltage	V _{CB0}	80V	50V	30V	30V	50V
Collector-Emitter Voltage (V _{BE} =0)	V _{CE5}	80V	50V	30V	30V	50V
Collector-Emitter Voltage (I _B =0)	V _{CEO}	65V	45V	30V	30V	45V
Emitter-Base Voltage	V _{EB0}	6V	6V	5V	5V	5V
Collector Current	I _C			100mA		
Collector Peak Current	I _{CM}			200mA		
Total Power Dissipation (T _A ≤ 25°C)	P _{tot}			500mW		
				derate 4mW/°C above 25°C		
Operating Junction & Storage Temperature T _j , T _{stg}				-55 to 150°C		

ELECTRICAL CHARACTERISTICS (T_A=25°C unless otherwise noted)*

PARAMETER	SYMBOL	MIN	TYP	MAX	UNIT	TEST CONDITIONS
Collector-Base Breakdown Voltage	BV _{CB0}					I _C =10 μ A I _B =0
BC546		80			V	
BC547		50			V	
BC548		30			V	
BC549		30			V	
BC550	50			V		
Collector-Emitter Breakdown Voltage	BV _{CE5}					I _C =10 μ A V _{BE} =0
BC546		80			V	
BC547		50			V	
BC548		30			V	
BC549		30			V	
BC550	50			V		
Collector-Emitter Breakdown Voltage	LV _{CEO}					I _C =2mA (Pulsed) I _B =0
BC546		65			V	
BC547		45			V	
BC548		30			V	
BC549		30			V	
BC550	45			V		

BC546 through BC550

PARAMETER	SYMBOL	MIN	TYP	MAX	UNIT	TEST CONDITIONS
Emitter-Base Breakdown Voltage BC546, 547 BC548, 549, 550	V _{BEBO}	6			V	I _E =1 μ A I _C =0
		5			V	
Collector Cutoff Current	I _{CBO}		15		nA	V _{CB} =30V I _E =0
				5	μ A	V _{CB} =30V I _E =0 T _A =150°C
Collector-Emitter Saturation Voltage	V _{CE(sat)}	0.07	0.25		V	I _C =10mA I _B =0.5mA
		0.22	0.6		V	I _C =100mA I _B =5mA (Pulsed)
Collector-Emitter Knee Voltage	V _{CEK}	0.3	0.6		V	I _C =10mA, I _B =value at which I _C =11mA V _{CE} =1V
Base-Emitter Saturation Voltage	V _{BE(sat)}	0.7			V	I _C =10mA I _B =0.5mA
		0.9			V	I _C =100mA I _B =5mA (Pulsed)
Base-Emitter Voltage	V _{BE}	0.58	0.63	0.7	V	I _C =2mA V _{CE} =5V
		0.68	0.77		V	I _C =10mA V _{CE} =5V
Current Gain-Bandwidth Product	f _T		250		MHz	I _C =10mA V _{CE} =5V
Collector-Base Capacitance	C _{ob}	2.7	4.5		pF	V _{CB} =10V I _E =0 f=1MHz
Noise Figure BC546, 547, 548 BC549, 550	NF		2	10	dB	I _C =0.2mA V _{CE} =5V R _G =2K Ω f=1kHz
			1.4	4	dB	Δ f=200Hz
Noise Figure BC549 only BC550 only	NF		1.2	4	dB	I _C =0.2mA V _{CE} =5V R _G =2K Ω f=30Hz-15kHz
			1.2	3	dB	
Flicker Noise Voltage Referred to Base BC549, 550 only	\overline{E}_n		0.135		μ V	I _C =0.2mA V _{CE} =5V R _G =2K Ω f=10Hz-50Hz

FLICKER NOISE MEASUREMENT

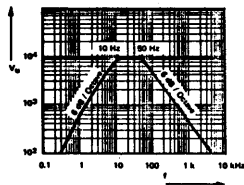
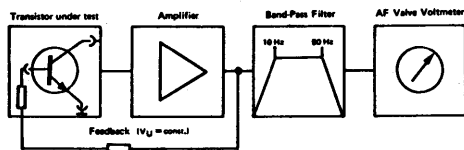

BC546 through BC550

D.C. CURRENT GAIN (H_{FE}) AT $V_{CE}=5V$ $T_A=25^\circ C$

I_C	BC546, BC547 BC548			BC546, BC547 BC548 BC549, BC550			BC548 BC549, BC550		
	HFE GROUP A			HFE GROUP B			HFE GROUP C		
	MIN	TYP	MAX	MIN	TYP	MAX	MIN	TYP	MAX
0.01mA	90			170			290		
2mA	110	170	220	200	300	450	420	520	800
100mA	100			160			270		

h - PARAMETERS AT $I_C=2mA$ $V_{CE}=5V$ $f=1kHz$ $T_A=25^\circ C$

h - PARAMETER	SYMBOL	HFE GROUP A			HFE GROUP B			HFE GROUP C			UNIT
		MIN	TYP	MAX	MIN	TYP	MAX	MIN	TYP	MAX	
Input Impedance	h_{ie}	1.6	2.7	4.5	3.2	4.5	8.5	6	8.7	15	$k\Omega$
Voltage Feedback Ratio	h_{re}	1.5			2			3			$\times 10^{-4}$
Small Signal Current Gain	h_{fe}	125	190	260	240	330	500	450	580	900	
Output Admittance	h_{oe}	18			30			60			μS

TYPICAL CHARACTERISTICS AT $T_A=25^\circ C$ (Pulse Test)

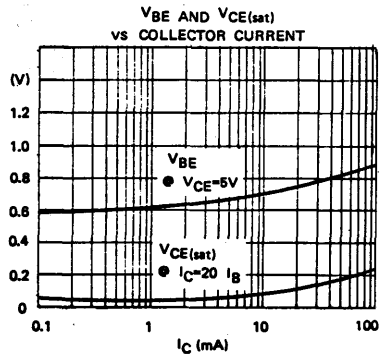
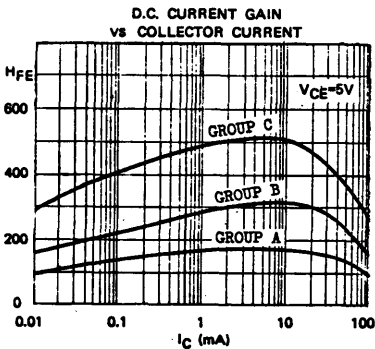

BC546 through BC550

TYPICAL CHARACTERISTICS ($T_A=25^\circ\text{C}$ UNLESS OTHERWISE SPECIFIED)

COMMON EMITTER
OUTPUT CHARACTERISTICS

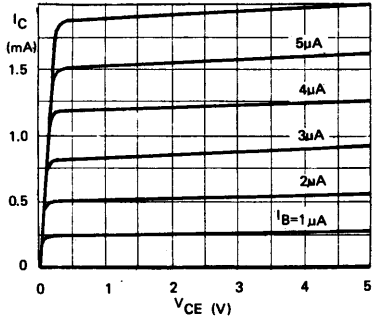

CURRENT GAIN - BANDWIDTH PRODUCT
VS COLLECTOR CURRENT

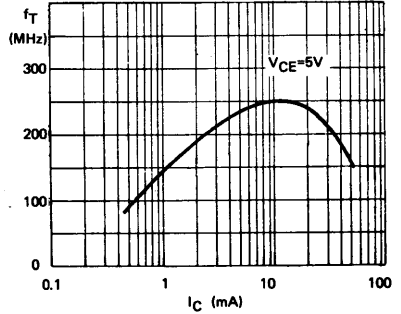

COLLECTOR CUTOFF CURRENT
VS AMBIENT TEMPERATURE

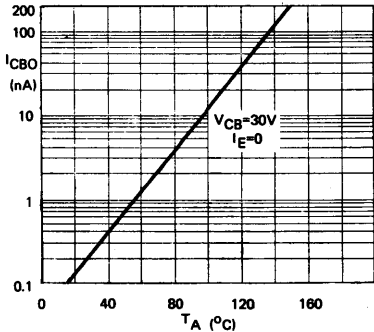

h-PARAMETERS (NORMALIZED)
VS COLLECTOR CURRENT

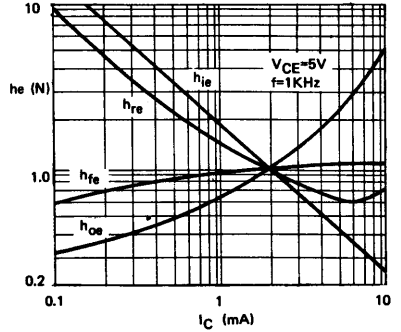

EQUIVALENT NOISE VOLTAGE AT BASE
VS COLLECTOR CURRENT

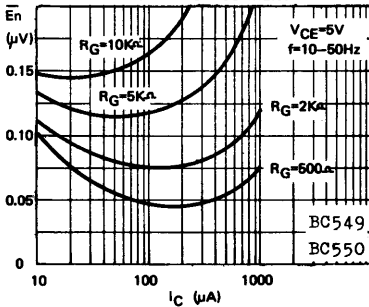

BROAD BAND NOISE FIGURE
VS COLLECTOR CURRENT

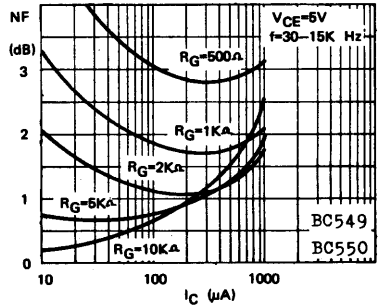

BC556 through BC560

PNP SILICON AF SMALL SIGNAL TRANSISTORS

THE BC556 THROUGH BC560 ARE PNP SILICON PLANAR EPITAXIAL TRANSISTORS FOR USE IN AF SMALL SIGNAL AMPLIFIER STAGES AND DIRECT COUPLED CIRCUITS. THEY ARE COMPLEMENTARY TO BC546 THROUGH BC550.

THE BC559, BC560 ARE CHARACTERIZED BY LOW NOISE FIGURE.

CASE TO-92F



ABSOLUTE MAXIMUM RATINGS

		BC556	BC557	BC558	BC559	BC560
Collector-Base Voltage	-V _{CB0}	80V	50V	30V	30V	50V
Collector-Emitter Voltage (V _{BE} =0)	-V _{CE5}	80V	50V	30V	30V	50V
Collector-Emitter Voltage (I _B =0)	-V _{CE0}	65V	45V	30V	30V	45V
Emitter-Base Voltage	-V _{EB0}			5V		
Collector Current	-I _C			100mA		
Collector Peak Current	-I _{CM}			200mA		
Total Power Dissipation (T _A ≤ 25°C)	P _{tot}			500mW		
				derate 4mW/°C above 25°C		
Operating Junction & Storage Temperature T _j , T _{stg}				-55 to 150°C		

ELECTRICAL CHARACTERISTICS (T_A=25°C unless otherwise noted)

PARAMETER	SYMBOL	MIN	TYP	MAX	UNIT	TEST CONDITIONS
Collector-Base Breakdown Voltage	-BV _{CB0}					-I _C =10μA I _E =0
BC556		80			V	
BC557		50			V	
BC558		30			V	
BC559		30			V	
BC560		50			V	
Collector-Emitter Breakdown Voltage	-BV _{CE5}					-I _C =10μA V _{BE} =0
BC556		80			V	
BC557		50			V	
BC558		30			V	
BC559		30			V	
BC560		50			V	
Collector-Emitter Breakdown Voltage	-LV _{CE0}					-I _C =2mA (Pulsed) I _B =0
BC556		65			V	
BC557		45			V	
BC558		30			V	
BC559		30			V	
BC560		45			V	

BC556 through BC560

D.C. CURRENT GAIN (HFE) AT $-V_{CE}=5V$ $T_A=25^\circ C$

$\ominus -I_C$	BC556, BC557 BC558			BC556, BC557 BC558 BC559, BC560			BC556, BC557 BC558 BC559, BC560			BC558 BC559, BC560		
	HFE GROUP VI			HFE GROUP A			HFE GROUP B			HFE GROUP C		
	MIN	TYP	MAX	MIN	TYP	MAX	MIN	TYP	MAX	MIN	TYP	MAX
0.01mA	70			110			200			330		
2mA	70	110	140	110	170	220	200	300	450	420	520	800
100mA	60			80			140			240		

h - PARAMETERS AT $-I_C=2mA$ $-V_{CE}=5V$ $f=1kHz$ $T_A=25^\circ C$

h - PARAMETER	SYMBOL	HFE GROUP VI			HFE GROUP A			HFE GROUP B			HFE GROUP C			UNIT
		MIN	TYP	MAX	MIN	TYP	MAX	MIN	TYP	MAX	MIN	TYP	MAX	
Input Impedance	h_{ie}	1.4			2.7			4.5			8.7			Ω
Voltage Feedback Ratio	h_{re}	2.5			3			3.5			4			$\times 10^{-4}$
Small Signal Current Gain	h_{fe}	75	110	150	125	190	260	240	330	500	450	580	900	
Output Admittance	h_{oe}	20			25			35			60			μV

TYPICAL CHARACTERISTICS AT $T_A=25^\circ C$ (Pulse Test)

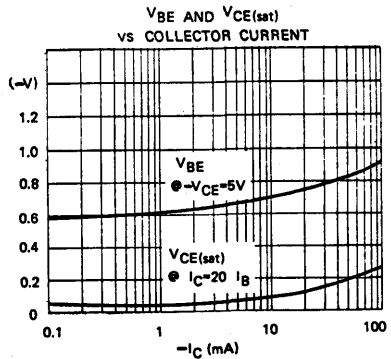
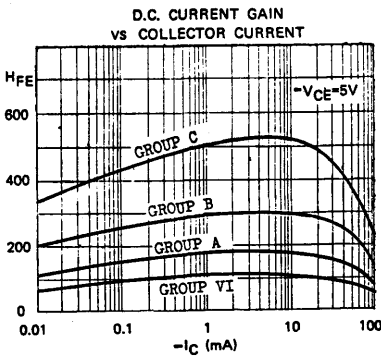

BC556 through BC560

PARAMETER	SYMBOL	MIN	TYP	MAX	UNIT	TEST CONDITIONS
Emitter-Base Breakdown Voltage	$-BV_{EBO}$	5			V	$-I_B=1\mu A$ $I_C=0$
Collector Cutoff Current	$-I_{CBO}$		15		nA	$-V_{CB}=30V$ $I_B=0$
			5		μA	$-V_{CB}=30V$ $I_B=0$ $T_A=150^\circ C$
Collector-Emitter Saturation Voltage	$-V_{CE(sat)}$	0.1	0.3		V	$-I_C=10mA$ $-I_B=0.5mA$
		0.25	0.65		V	$-I_C=100mA$ $-I_B=5mA$ (Pulsed)
Collector-Emitter Knee Voltage	$-V_{CEK}$	0.3	0.6		V	$-I_C=10mA$, I_B -value at which $-I_C=11mA$ $-V_{CE}=1V$
Base-Emitter Saturation Voltage	$-V_{BE(sat)}$	0.72			V	$-I_C=10mA$ $-I_B=0.5mA$
		0.92			V	$-I_C=100mA$ $-I_B=5mA$ (Pulsed)
Base-Emitter Voltage	$-V_{BE}$	0.6	0.65	0.75	V	$-I_C=2mA$ $-V_{CE}=5V$
		0.7	0.82		V	$-I_C=10mA$ $-V_{CE}=5V$
Current Gain-Bandwidth Product	f_T		180		MHz	$-I_C=10mA$ $-V_{CE}=5V$
Collector-Base Capacitance	C_{ob}		3.2		pF	$-V_{CB}=10V$ $I_E=0$ $f=1MHz$
Noise Figure BC556, 557, 558 BC559, 560	NF		2	10	dB	$-I_C=0.2mA$ $-V_{CE}=5V$ $R_G=2K\Omega$ $f=1kHz$
			1.2	4	dB	$\Delta f=200Hz$
Noise Figure BC559 only BC560 only	NF		1.2	4	dB	$-I_C=0.2mA$ $-V_{CE}=5V$ $R_G=2K\Omega$ $f=30Hz-15kHz$
			1.2	2	dB	
Flicker Noise Voltage Referred to Base BC559, 560 only	\overline{E}_n			0.11	μV	$-I_C=0.2mA$ $-V_{CE}=5V$ $R_G=2K\Omega$ $f=10-50Hz$

FLICKER NOISE MEASUREMENT

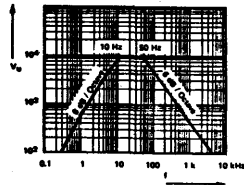
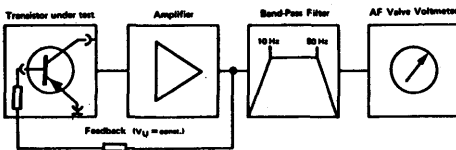

BC556 through BC560

TYPICAL CHARACTERISTICS ($T_A=25^\circ\text{C}$ UNLESS OTHERWISE SPECIFIED)

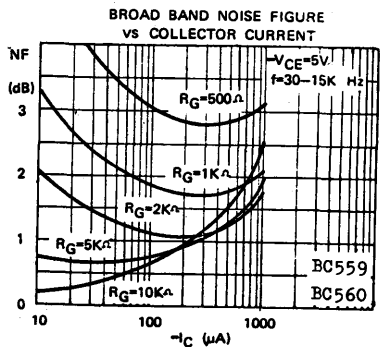
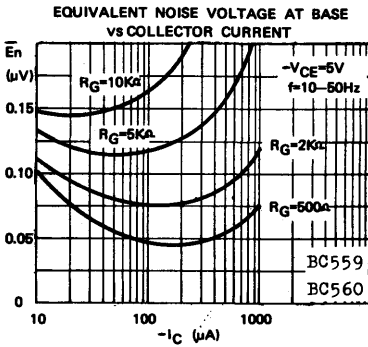
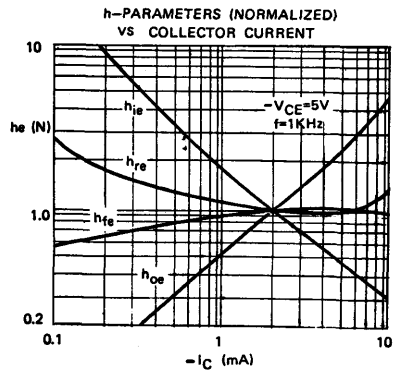
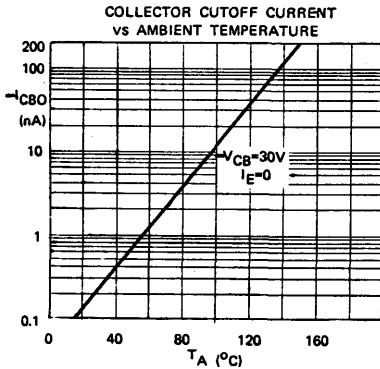
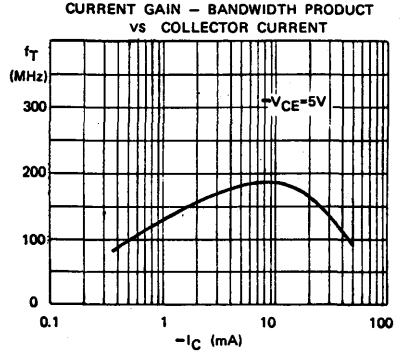
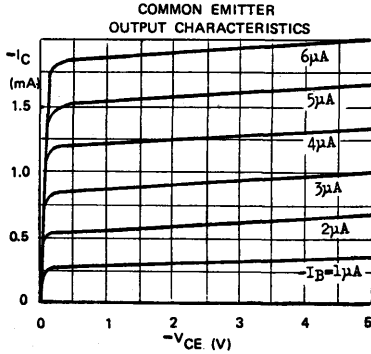

BC727 BC728

PNP SILICON AF MEDIUM POWER TRANSISTORS

THE BC727, BC728 ARE PNP SILICON PLANAR EPITAXIAL TRANSISTORS FOR USE IN AF DRIVER AND OUTPUT STAGES, AS WELL AS FOR UNIVERSAL APPLICATIONS. THE BC727, BC728 ARE COMPLEMENTARY TO THE NPN TYPE BC737, BC738 RESPECTIVELY.

CASE TO-92A



EBC

ABSOLUTE MAXIMUM RATINGS

	BC727	BC728
Collector-Base Voltage	-V _{CB0} 50V	30V
Collector-Emitter Voltage	-V _{CE0} 40V	25V
Emitter-Base Voltage	-V _{EB0}	5V
Collector Current	-I _C	1.5A
Collector Peak Current (t ≤ 10ms)	-I _{CM}	2.5A
Total Power Dissipation (@ T _C ≤ 25°C) (@ T _A ≤ 25°C)	P _{tot}	1.5W 625mW
Operating Junction & Storage Temperature	T _j , T _{stg}	-55 to 150°C

THERMAL RESISTANCE

Junction to Case	θ _{jc}	83°C/W max.
Junction to Ambient	θ _{ja}	200°C/W max.

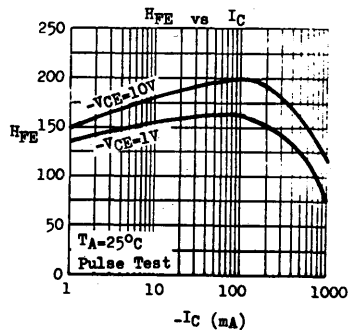
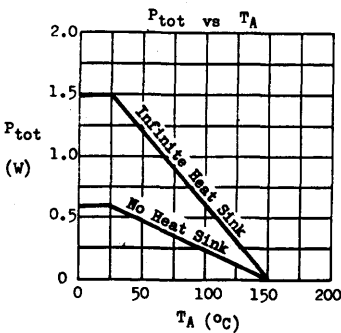

BC727 BC728

ELECTRICAL CHARACTERISTICS (T_A=25°C unless otherwise noted)

PARAMETER	SYMBOL	BC727		BC728		UNIT	TEST CONDITIONS
		MIN	TYP	MAX	MIN		
Collector-Base Breakdown Voltage	-BV _{CEO}	50			30	V	-I _C =0.1mA I _B =0
Collector-Emitter Breakdown Voltage	-LV _{CEO} *	40			25	V	-I _C =10mA I _B =0
Emitter-Base Breakdown Voltage	-BV _{EBO}	5			5	V	-I _E =0.1mA I _C =0
Collector Cutoff Current	-I _{CBO}		100			nA	-V _{CB} =40V I _E =0
					100	nA	-V _{CB} =25V I _E =0
Emitter Cutoff Current	-I _{EBO}		100		100	nA	-V _{EB} =4V I _C =0
Collector-Emitter Saturation Voltage	-V _{CE(sat)} *		0.7		0.7	V	-I _C =500mA -I _B =50mA
Base-Emitter Saturation Voltage	-V _{BE(sat)} *		1.2		1.2	V	-I _C =500mA -I _B =50mA
			1.3		1.3	V	-I _C =1A -I _B =0.1A
D.C. Current Gain	h _{FE} *	63	630	63	630		-I _C =100mA -V _{CE} =1V
Group 10		63	160	63	160		
Group 16		100	250	100	250		
Group 25		160	400	160	400		
Group 40		250	630	250	630		
	h _{FE} *	63		63			-I _C =500mA -V _{CE} =1V
All Groups		15		30			-I _C =1A -V _{CE} =1V
Current Gain-Bandwidth Product	f _T	40	120	40	120	MHz	-I _C =50mA -V _{CE} =10V
Collector-Base Capacitance	C _{ob}		17	20	17	20	pF
							-V _{CB} =10V I _E =0
							f=1MHz

* Pulse Test : Pulse Width=0.3ms, Duty Cycle=1%

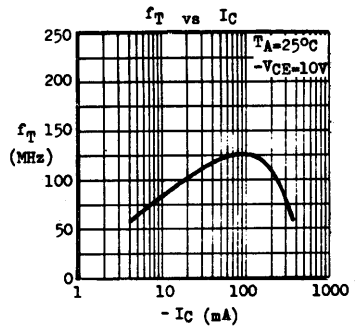
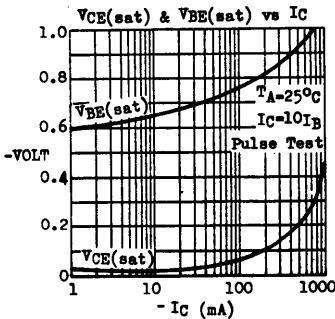

BC737 BC738

NPN SILICON AF MEDIUM POWER TRANSISTORS

THE BC737, BC738 ARE NPN SILICON PLANAR EPITAXIAL TRANSISTORS FOR USE IN AF DRIVER AND OUTPUT STAGES, AS WELL AS FOR UNIVERSAL APPLICATIONS. THE BC737, BC738 ARE COMPLEMENTARY TO THE PNP TYPE BC727, BC728 RESPECTIVELY.

CASE TO-92A



ABSOLUTE MAXIMUM RATINGS

Collector-Base Voltage
 Collector-Emitter Voltage
 Emitter-Base Voltage
 Collector Current
 Collector Peak Current ($t \leq 10\text{ms}$)
 Total Power Dissipation ($@ T_C \leq 25^\circ\text{C}$)
 ($@ T_A \leq 25^\circ\text{C}$)
 Operating Junction & Storage Temperature

	BC737	BC738
Collector-Base Voltage	50V	30V
Collector-Emitter Voltage	40V	25V
Emitter-Base Voltage		5V
Collector Current		1.5A
Collector Peak Current ($t \leq 10\text{ms}$)		2.5A
Total Power Dissipation ($@ T_C \leq 25^\circ\text{C}$) ($@ T_A \leq 25^\circ\text{C}$)	1.5W	625mW
Operating Junction & Storage Temperature	T_j, T_{stg}	-55 to 150°C

THERMAL RESISTANCE

Junction to Case
 Junction to Ambient

Junction to Case	θ_{jc}	83°C/W max.
Junction to Ambient	θ_{ja}	200°C/W max.

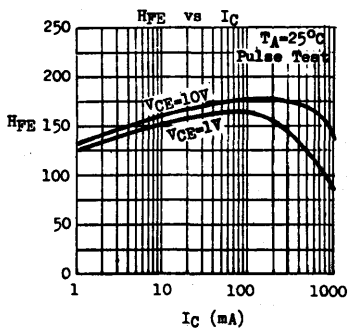
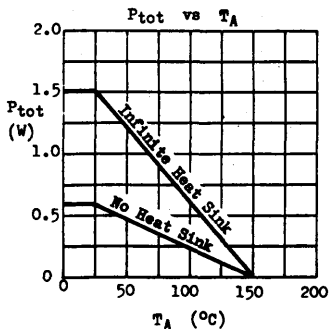

BC737 BC738

ELECTRICAL CHARACTERISTICS (T_A=25°C unless otherwise noted)

PARAMETER	SYMBOL	BC737		BC738		UNIT	TEST CONDITIONS	
		MIN	TYP MAX	MIN	TYP MAX			
Collector-Base Breakdown Voltage	BV _{CBO}	50		30		V	I _C =0.1mA I _B =0	
Collector-Emitter Breakdown Voltage	LV _{CEO} *	40		25		V	I _C =10mA I _B =0	
Emitter-Base Breakdown Voltage	BV _{EBO}	5		5		V	I _E =0.1mA I _C =0	
Collector Cutoff Current	I _{CBO}		100		100	nA	V _{CB} =40V I _E =0 V _{CB} =25V I _E =0	
Emitter Cutoff Current	I _{EBO}		100		100	nA	V _{EB} =4V I _C =0	
Collector-Emitter Saturation Voltage	V _{CE(sat)} *		0.7		0.7	V	I _C =500mA I _B =500mA	
Base-Emitter Saturation Voltage	V _{BE(sat)} *		1.2		1.2	V	I _C =500mA I _B =500mA	
			1.3		1.3	V	I _C =1A I _B =0.1A	
D.C. Current Gain	H _{FE} *	63	630	63	630		I _C =100mA V _{CE} =1V	
		Group 10	63	160	63	160		
		Group 16	100	250	100	250		
		Group 25	160	400	160	400		
		Group 40	250	630	250	630		
	All Groups	H _{FE} *	63 15	63 30			I _C =500mA V _{CE} =1V I _C =1A V _{CE} =1V	
Current Gain-Bandwidth Product	f _T	40	150	40	150	MHz	I _C =50mA V _{CE} =10V	
Collector-Base Capacitance	C _{ob}		12 20		12 20	pF	V _{CB} =10V I _E =0 f=1MHz	

* Pulse Test : Pulse Width=0.5ms, Duty Cycle=1%

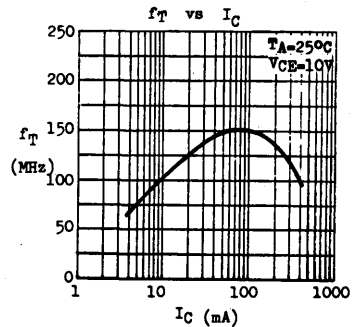
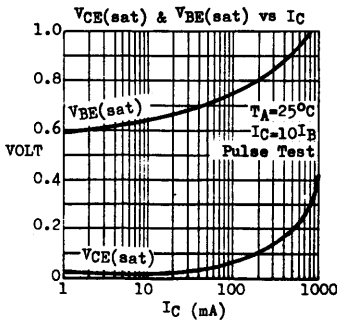

BD220 BD221 BD222

NPN SILICON SINGLE DIFFUSED MESA POWER TRANSISTORS

THE BD 220, BD 221 AND BD 222 ARE NPN SILICON SINGLE DIFFUSED MESA POWER TRANSISTORS DESIGNED FOR LOW SPEED SWITCHING AND AUDIO AMPLIFIER APPLICATIONS. THEY FEATURE LARGE SAFE OPERATING AREA.

CASE TO-220B



ABSOLUTE MAXIMUM RATINGS

Collector-Base Voltage
 Collector-Emitter Voltage
 Emitter-Base Voltage
 Collector Current
 Base Current
 Total Power Dissipation @ $T_C < 25^\circ\text{C}$
 @ $T_A < 25^\circ\text{C}$
 Junction Temperature
 Storage Temperature Range

	<u>BD 220</u>	<u>BD 221</u>	<u>BD 222</u>
V_{CB0}	80V	60V	80V
V_{CE0}	70V	40V	60V
V_{EB0}	7V	5V	5V
I_C		4A	
I_B		2A	
P_{tot}		36W	
		1.8W	
T_j		150°C	
T_{stg}		-55 to +150°C	

THERMAL RESISTANCE

Junction to Case
 Junction to Ambient

θ_{jc}	3.5°C/W	max.
θ_{ja}	70°C/W	max.

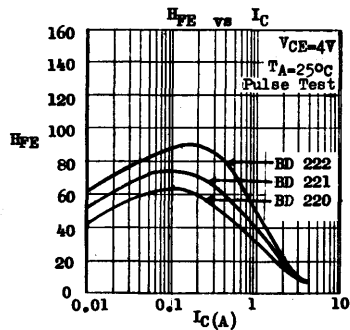
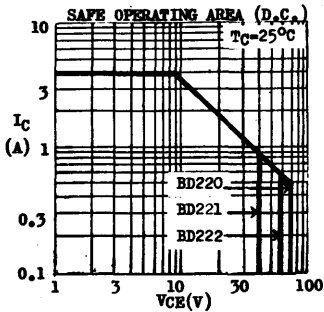

BD220 BD221 BD222

ELECTRICAL CHARACTERISTICS ($T_A=25^{\circ}\text{C}$ unless otherwise noted)

PARAMETER	SYMBOL	MIN	TYP	MAX	UNIT	TEST CONDITIONS
Collector-Emitter Breakdown Voltage	V_{CE0}^*					$I_C=0.1\text{A}$ $I_B=0$
BD 220		70			V	
BD 221		40			V	
BD 222		60			V	
Collector-Emitter Breakdown Voltage	V_{CER}^*					$I_C=0.1\text{A}$ $R_{BE}=100\Omega$
BD 220		75			V	
BD 221		50			V	
BD 222		70			V	
Collector-Emitter Breakdown Voltage	V_{CEV}^*					$I_C=0.1\text{A}$ $V_{EB}=1.5\text{V}$
BD 220/222		80			V	
BD 221		60			V	
Collector Cutoff Current	I_{CER}			0.5	mA	$V_{CE}=50\text{V}$ $R_{BE}=100\Omega$
BD 220/222				2	mA	$V_{CE}=50\text{V}$ $R_{BE}=100\Omega$
Collector Cutoff Current	I_{CEV}			0.5	mA	$V_{CE}=65\text{V}$ $V_{EB}=1.5\text{V}$
BD 220/222				2	mA	$V_{CE}=35\text{V}$ $V_{EB}=1.5\text{V}$
Collector Cutoff Current	I_{CEV}			3	mA	$V_{CE}=65\text{V}$ $V_{EB}=1.5\text{V}$
BD 220/222				5	mA	$V_{CE}=35\text{V}$ $V_{EB}=1.5\text{V}$
BD 221						$T_C=150^{\circ}\text{C}$
Emitter Cutoff Current	I_{EBO}			1	mA	$V_{EB}=7\text{V}$ $I_C=0$
BD 220				1	mA	$V_{EB}=5\text{V}$ $I_C=0$
BD 221/222						
Base-Emitter Voltage	V_{BE}^*	0.70	1.1		V	$I_C=0.5\text{A}$ $V_{CE}=4\text{V}$
BD 220		0.80	1.3		V	$I_C=1\text{A}$ $V_{CE}=4\text{V}$
BD 221		0.90	1.5		V	$I_C=1.5\text{A}$ $V_{CE}=4\text{V}$
BD 222						
Collector-Emitter Saturation Voltage	$V_{CE(sat)}^*$					
BD 220		0.15	1		V	$I_C=0.5\text{A}$ $I_B=0.05\text{A}$
BD 221		0.20	1		V	$I_C=1\text{A}$ $I_B=0.1\text{A}$
BD 222		0.30	1		V	$I_C=1.5\text{A}$ $I_B=0.15\text{A}$
D.C. Current Gain	H_{FE}^*	30		120		$I_C=0.5\text{A}$ $V_{CE}=4\text{V}$
BD 220		30		120		$I_C=1\text{A}$ $V_{CE}=4\text{V}$
BD 221		20		80		$I_C=1.5\text{A}$ $V_{CE}=4\text{V}$
BD 222						
Current Gain-Bandwidth product	f_T	0.8			MHz	$I_C=0.2\text{A}$ $V_{CE}=4\text{V}$

* Pulse Test : Pulse Width=0.3ms, Duty Cycle=1%

BD239 BD239A BD239B

NPN SILICON EPITAXIAL BASE POWER TRANSISTORS

THE BD 239, BD 239A AND BD 239B ARE NPN SILICON EPITAXIAL BASE POWER TRANSISTORS DESIGNED FOR SWITCHING, DRIVER AND OUTPUT STAGES IN AUDIO AMPLIFIERS. THE BD 239, BD 239A AND BD 239B ARE COMPLEMENTARY TO BD 240, BD 240A AND BD 240B RESPECTIVELY.

CASE TO-220B



ABSOLUTE MAXIMUM RATINGS

Collector-Emitter Voltage
with $R_{BE}=100\Omega$
with base open

Emitter-Base Voltage

Collector Current

Base Current

Total Power Dissipation ($T_C < 25^\circ\text{C}$)

Junction Temperature

Storage Temperature Range

	BD 239	BD 239A	BD 239B
V_{CE}	55V	70V	90V
V_{CE0}	45V	60V	80V
V_{EB0}		5V	
I_C		2A	
I_B		1A	
P_{tot}		30W	
T_j		150°C	
T_{stg}		-55 to +150°C	

THERMAL RESISTANCE

Junction to Case

θ_{jc} 4.17°C/W max.

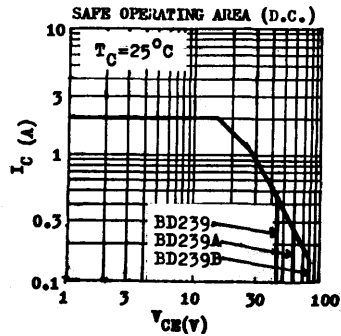
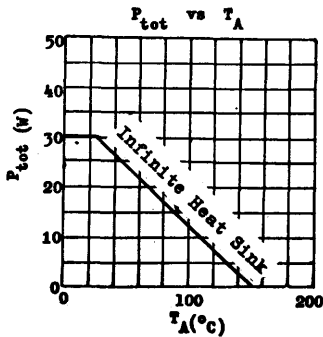

BD239 BD239A BD239B

ELECTRICAL CHARACTERISTICS ($T_A = 25^\circ\text{C}$ unless otherwise noted)

PARAMETER	SYMBOL	MIN	MAX	UNIT	TEST CONDITIONS
Collector-Emitter Breakdown Voltage : with external base-emitter resistance	V_{CEB} *	55		V	$I_C = 30\text{mA}$ $R_{BE} = 100\ \Omega$
		70		V	
		90		V	
with base open	V_{CE0} *	45		V	$I_C = 30\text{mA}$ $I_B = 0$
		60		V	
		80		V	
Collector Cutoff Current	I_{CE0}		0.3	mA	$V_{CE} = 30\text{V}$ $I_B = 0$ $V_{CE} = 60\text{V}$ $I_B = 0$
		BD 239, BD 239A BD 239B		0.3	
Collector Cutoff Current	I_{CES}	BD 239	0.2	mA	$V_{CE} = 45\text{V}$ $V_{BE} = 0$ $V_{CE} = 60\text{V}$ $V_{BE} = 0$ $V_{CE} = 80\text{V}$ $V_{BE} = 0$
		BD 239A	0.2	mA	
		BD 239B	0.2	mA	
Emitter Cutoff Current	I_{EB0}		1	mA	$V_{EB} = 5\text{V}$ $I_C = 0$
Collector-Emitter Saturation Voltage	$V_{CE(sat)}$ *		0.7	V	$I_C = 1\text{A}$ $I_B = 0.2\text{A}$
Base-Emitter Voltage	V_{BE} *		1.3	V	$I_C = 1\text{A}$ $V_{CE} = 4\text{V}$
D.C. Current Gain	H_{FE} *	40			$I_C = 0.2\text{A}$ $V_{CE} = 4\text{V}$
		15			$I_C = 1\text{A}$ $V_{CE} = 4\text{V}$
Current Gain-Bandwidth Product	f_T	3		MHz	$I_C = 0.2\text{A}$ $V_{CE} = 10\text{V}$

* False Test : Pulse Width = 0.3ms, Duty Cycle = 1%

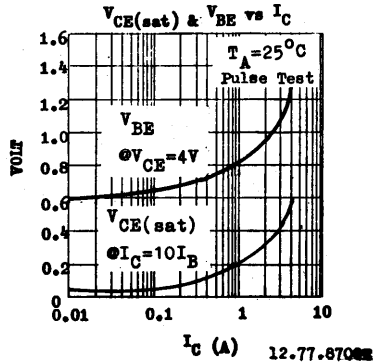
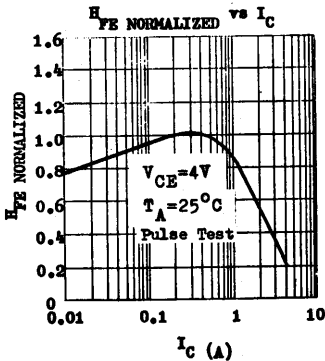

12.77-87002

BD239C through BD242C

COMPLEMENTARY

SILICON EPITAXIAL BASE AF POWER TRANSISTORS

THE BD239C THROUGH BD242C ARE COMPLEMENTARY SILICON EPITAXIAL BASE AF POWER TRANSISTORS. THEY FEATURE 100V MINIMUM COLLECTOR TO EMITTER BREAKDOWN VOLTAGE. THE BD239C, BD241C ARE NPN. THE BD240C, BD242C ARE PNP.

CASE TO-220B



ABSOLUTE MAXIMUM RATINGS For p-n-p device, voltage and current values are negative.

	BD239C(NPN) BD240C(PNP)	BD241C(NPN) BD242C(PNP)
Collector-Emitter Voltage ($I_{BE}=100\mu A$)	V_{CE} 115V	115V
Collector-Emitter Voltage ($I_B=0$)	V_{CEO} 100V	100V
Emitter-Base Voltage	V_{EB} 5V	5V
Collector Current	I_C 2A	3A
Total Power Dissipation ($T_C \leq 25^\circ C$)	P_{tot} 30W	40W
		2W
Operating Junction & Storage Temperature	T_j, T_{stg}	-55 to 150°C

THERMAL RESISTANCE

Junction to Case	θ_{jc} 4.17°C/W max.	3.12°C/W max.
Junction to Ambient	θ_{ja} 62.5°C/W max.	62.5°C/W max.

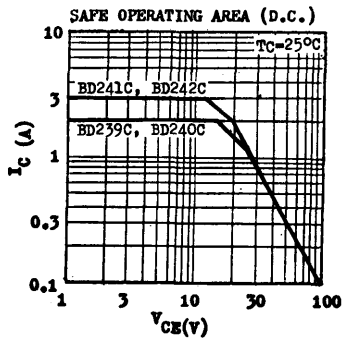
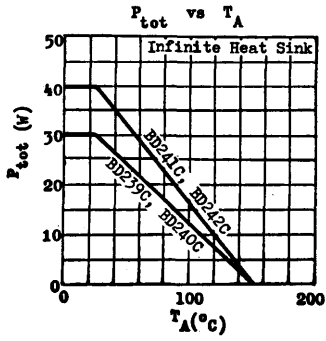

BD239C through BD242C

ELECTRICAL CHARACTERISTICS (T_A=25°C)

PARAMETER	SYMBOL	BD239C BD240C		BD241C BD242C		UNIT	TEST CONDITIONS
		MIN	MAX	MIN	MAX		
Collector-Emitter Breakdown Voltage	LV _{CER} *	115		115		V	I _C =30mA R _{BE} =100Ω
Collector-Emitter Breakdown Voltage	LV _{CBO} *	100		100		V	I _C =30mA I _B =0
Collector Cutoff Current	I _{CBO}	0.3		0.3		mA	V _{CE} =60V I _B =0
Collector Cutoff Current	I _{CES}	0.2		0.2		mA	V _{CE} =100V V _{BE} =0
Emitter Cutoff Current	I _{EBO}	1		1		mA	V _{EB} =5V I _C =0
Collector-Emitter Saturation Voltage	V _{CE(sat)} *	0.7		1.2		V	I _C =1A I _B =0.2A
						V	I _C =3A I _B =0.6A
Base-Emitter Voltage	V _{BE} *	1.3		1.8		V	I _C =1A V _{CE} =4V
						V	I _C =3A V _{CE} =4V
D.C. Current Gain	h _{FE} *	40		25			I _C =0.2A V _{CE} =4V
		15		10			I _C =1A V _{CE} =4V
							I _C =3A V _{CE} =4V
Small Signal Current Gain	h _{fe}			20			I _C =0.5A V _{CE} =10V f=1kHz
Current Gain-Bandwidth Product	f _T	3		3		MHz	I _C =0.2A V _{CE} =10V
						MHz	I _C =0.5A V _{CE} =10V

* Pulse Test : Pulse Width=0.3ms, Duty Cycle=1%

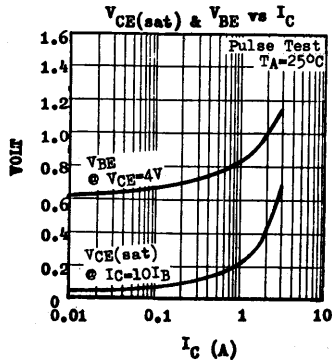
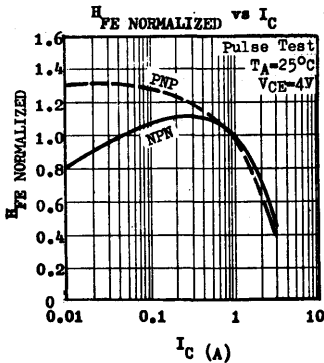

BD240 BD240A BD240B

PNP SILICON EPITAXIAL BASE POWER TRANSISTORS

THE BD 240, BD 240A AND BD 240B ARE PNP SILICON EPITAXIAL BASE POWER TRANSISTORS DESIGNED FOR SWITCHING, DRIVER AND OUTPUT STAGES IN AUDIO AMPLIFIERS. THE BD 240, BD 240A AND BD 240B ARE COMPLEMENTARY TO BD 239, BD 239A AND BD 239B RESPECTIVELY.

CASE TO-220B



ABSOLUTE MAXIMUM RATINGS

Collector-Emitter Voltage
with $R_{BE}=100\Omega$
with base open

$-V_{CE}$
 $-V_{CEO}$

BD 240 BD 240A BD 240B

55V 70V 90V
45V 60V 80V

Emitter-Base Voltage

$-V_{EB}$

5V

Collector Current

$-I_C$

2A

Base Current

$-I_B$

1A

Total Power Dissipation ($T_C < 25^\circ\text{C}$)

P_{tot}

30W

Junction Temperature

T_j

150°C

Storage Temperature Range

T_{stg}

-55 to +150°C

THERMAL RESISTANCE

Junction to Case

θ_{jc}

4.17°C/W max.

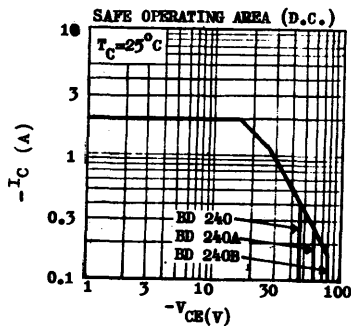
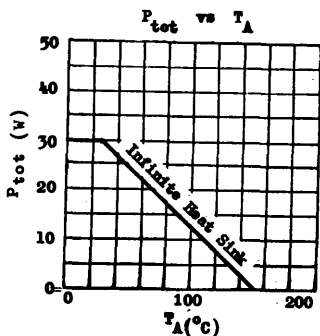

BD240 BD240A BD240B

ELECTRICAL CHARACTERISTICS ($T_A=25^\circ\text{C}$ unless otherwise noted)

PARAMETER	SYMBOL	MIN	MAX	UNIT	TEST CONDITIONS
Collector-Emitter Breakdown Voltage With external base-emitter resistance	$-V_{CER}^*$				$-I_C=50\text{mA}$ $R_{BE}=100\Omega$
BD 240		55		V	
BD 240A		70		V	
BD 240B		90		V	
With base open	$-V_{CEO}^*$				$-I_C=50\text{mA}$ $I_B=0$
BD 240		45		V	
BD 240A		60		V	
BD 240B		80		V	
Collector Cutoff Current	$-I_{CEO}$				
BD 240, BD 240A		0.3		mA	$-V_{CE}=30\text{V}$ $I_B=0$
BD 240B		0.3		mA	$-V_{CE}=60\text{V}$ $I_B=0$
Collector Cutoff Current	$-I_{CES}$				
BD 240		0.2		mA	$-V_{CE}=45\text{V}$ $V_{BE}=0$
BD 240A		0.2		mA	$-V_{CE}=60\text{V}$ $V_{BE}=0$
BD 240B		0.2		mA	$-V_{CE}=80\text{V}$ $V_{BE}=0$
Emitter Cutoff Current	$-I_{EBO}$		1	mA	$-V_{BE}=5\text{V}$ $I_C=0$
Collector-Emitter Saturation Voltage	$-V_{CE(sat)}^*$	0.7		V	$-I_C=1\text{A}$ $-I_B=0.2\text{A}$
Base-Emitter Voltage	$-V_{BE}^*$	1.3		V	$-I_C=1\text{A}$ $-V_{CE}=4\text{V}$
D.C. Current Gain	H_{FE}^*	40			$-I_C=0.2\text{A}$ $-V_{CE}=4\text{V}$
		15			$-I_C=1\text{A}$ $-V_{CE}=4\text{V}$
Current Gain-Bandwidth Product	f_T	3		MHz	$-I_C=0.2\text{A}$ $-V_{CE}=10\text{V}$

* Pulse Test : Pulse Width=0.3ms, Duty Cycle=1%

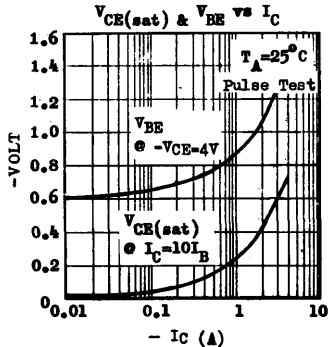
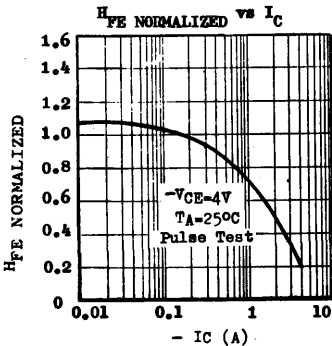

BD241 BD241A BD241B

NPN SILICON EPITAXIAL BASE POWER TRANSISTORS

THE BD 241, BD 241A AND BD 241B ARE NPN SILICON EPITAXIAL BASE POWER TRANSISTORS DESIGNED FOR SWITCHING, DRIVER AND OUTPUT STAGES IN AUDIO AMPLIFIERS. THE BD 241, BD 241A AND BD 241B ARE COMPLEMENTARY TO BD 242, BD 242A AND BD 242B RESPECTIVELY.

CASE TO-220B



ABSOLUTE MAXIMUM RATINGS

Collector-Emitter Voltage ($R_{BE}=100\Omega$)
 Collector-Emitter Voltage ($I_B=0$)
 Emitter-Base Voltage
 Collector Current
 Base Current
 Total Power Dissipation @ $T_C \leq 25^\circ\text{C}$
 @ $T_A \leq 25^\circ\text{C}$
 Junction and Storage Temperature

	BD241	BD241A	BD241B
V_{CE}	55V	70V	90V
V_{CEO}	45V	60V	80V
V_{EB}		5V	
I_C		3A	
I_B		1A	
P_{tot}		40W	
		2W	
T_j, T_{stg}		-55 to +150°C	

THERMAL RESISTANCE

Junction to Case
 Junction to Ambient

θ_{jc}	3.12°C/W	max.
θ_{ja}	62.5°C/W	max.

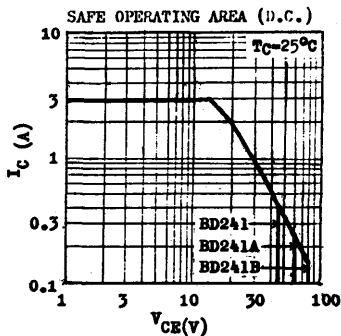
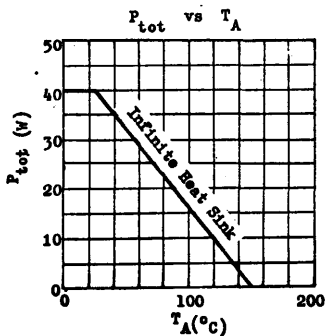

BD241 BD241A BD241B

ELECTRICAL CHARACTERISTICS (TA=25°C unless otherwise noted)

PARAMETER	SYMBOL	MIN	MAX	UNIT	TEST CONDITIONS
Collector-Emitter Breakdown Voltage	V_{CE0}^*				$I_C=30mA \quad I_B=0$
BD241		45		V	
BD241A		60		V	
BD241B		80		V	
Collector Cutoff Current	I_{CE0}				$V_{CE}=30V \quad I_B=0$ $V_{CE}=60V \quad I_B=0$
BD241, BD241A		0.3		mA	
BD241B		0.3		mA	
Collector Cutoff Current	I_{CES}				$V_{CE}=45V \quad V_{BE}=0$ $V_{CE}=60V \quad V_{BE}=0$ $V_{CE}=80V \quad V_{BE}=0$
BD241		0.2		mA	
BD241A BD241B		0.2		mA	
Emitter Cutoff Current	I_{E0}		1	mA	$V_{BE}=5V \quad I_C=0$
Base-Emitter Voltage	V_{BE}^*		1.8	V	$I_C=3A \quad V_{CE}=4V$
Collector-Emitter Saturation Voltage	$V_{CE(sat)}^*$		1.2	V	$I_C=3A \quad I_B=0.6A$
D.C. Current Gain	H_{FE}^*	25			$I_C=1A \quad V_{CE}=4V$
		10			$I_C=3A \quad V_{CE}=4V$
Small Signal Current Gain	h_{fe}	20			$I_C=0.5A \quad V_{CE}=10V$ $f=1kHz$
Current Gain-Bandwidth Product	f_T	3		MHz	$I_C=0.5A \quad V_{CE}=10V$

* Pulse Test : Pulse Width=0.3ms, Duty Cycle=1%

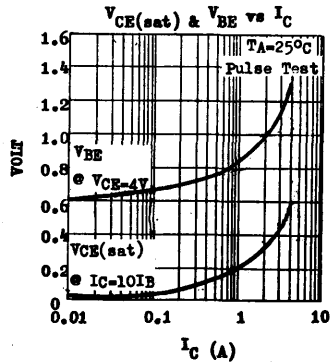
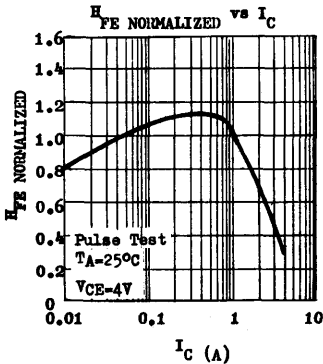

BD242 BD242A BD242B

PNP SILICON EPITAXIAL BASE POWER TRANSISTORS

THE BD 242, BD 242A AND BD 242B ARE PNP SILICON EPITAXIAL BASE POWER TRANSISTORS DESIGNED FOR SWITCHING, DRIVER AND OUTPUT STAGES IN AUDIO AMPLIFIERS. THE BD 242, BD 242A AND BD 242B ARE COMPLEMENTARY TO BD 241, BD 241A AND BD 241B RESPECTIVELY.

CASE TO-220B



ABSOLUTE MAXIMUM RATINGS

		BD242	BD242A	BD242B
Collector-Emitter Voltage (RBE=100 Ω)	-V _{CE}	55V	70V	90V
Collector-Emitter Voltage (I _B =0)	-V _{CEO}	45V	60V	80V
Emitter-Base Voltage	-V _{EB0}		5V	
Collector Current	-I _C		3A	
Base Current	-I _B		1A	
Total Power Dissipation ● T _C ≤ 25°C	P _{tot}		40W	
● T _A ≤ 25°C			2W	
Junction and Storage Temperature	T _j , T _{stg}		-55 to +150°C	

THERMAL RESISTANCE

Junction to Case	θ_{jc}	3.12°C/W	max.
Junction to Ambient	θ_{ja}	62.5°C/W	max.

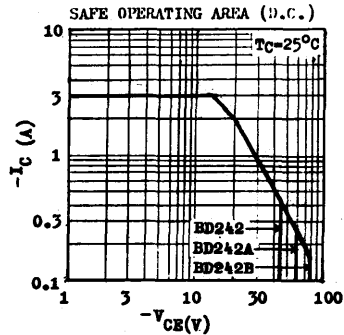
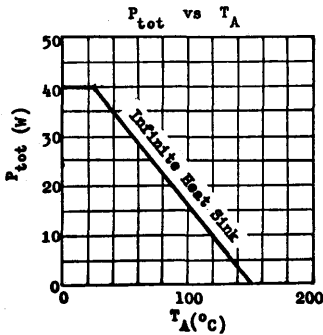

BD242 BD242A BD242B

ELECTRICAL CHARACTERISTICS ($T_A=25^\circ\text{C}$ unless otherwise noted)

PARAMETER	SYMBOL	MIN	MAX	UNIT	TEST CONDITIONS
Collector-Emitter Breakdown Voltage BD242 BD242A BD242B	$-V_{CE0}^*$	45 60 80		V V V	$-I_C=30\text{mA}$ $I_B=0$
Collector Cutoff Current BD242, BD242A BD242B	$-I_{CE0}$	0.3 0.3		mA mA	$-V_{CE}=30\text{V}$ $I_B=0$ $-V_{CE}=60\text{V}$ $I_B=0$
Collector Cutoff Current BD242 BD242A BD242B	$-I_{CES}$	0.2 0.2 0.2		mA mA mA	$-V_{CE}=45\text{V}$ $V_{BE}=0$ $-V_{CE}=60\text{V}$ $V_{BE}=0$ $-V_{CE}=80\text{V}$ $V_{BE}=0$
Emitter Cutoff Current	$-I_{E0}$	1		mA	$-V_{EB}=5\text{V}$ $I_C=0$
Base-Emitter Voltage	$-V_{BE}^*$	1.8		V	$-I_C=3\text{A}$ $-V_{CE}=4\text{V}$
Collector-Emitter Saturation Voltage	$-V_{CE(sat)}^*$	1.2		V	$-I_C=3\text{A}$ $-I_B=0.6\text{A}$
D.C. Current Gain	H_{FE}^*	25 10			$-I_C=1\text{A}$ $-V_{CE}=4\text{V}$ $-I_C=3\text{A}$ $-V_{CE}=4\text{V}$
Small Signal Current Gain	h_{fe}	20			$-I_C=0.5\text{A}$ $-V_{CE}=10\text{V}$ $f=1\text{kHz}$
Current Gain-Bandwidth Product	f_T	3		MHz	$-I_C=0.5\text{A}$ $-V_{CE}=10\text{V}$

* Pulse Test : Pulse Width=0.3ms, Duty Cycle=1%

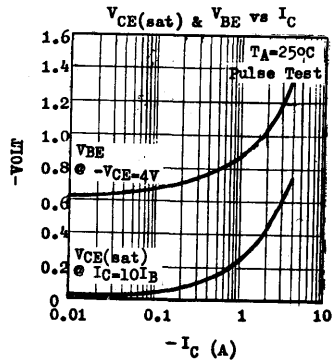
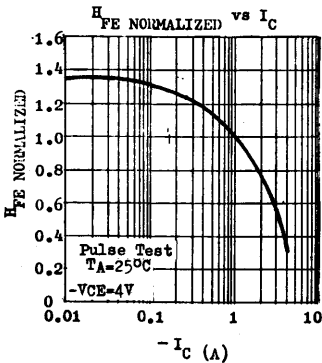

BD533 BD535 BD537

NPN SILICON EPITAXIAL BASE POWER TRANSISTORS

THE BD 533, BD 535 AND BD 537 ARE NPN SILICON EPITAXIAL BASE POWER TRANSISTORS DESIGNED FOR SWITCHING, DRIVER AND OUTPUT STAGES IN AUDIO AMPLIFIERS. THE BD 533, BD 535 AND BD 537 ARE COMPLEMENTARY TO ED 534, ED 536 AND ED 538 RESPECTIVELY.

CASE TO-220B



ABSOLUTE MAXIMUM RATINGS

Collector-Base Voltage	V_{CB0}
Collector-Emitter Voltage	V_{CE0}
Emitter-Base Voltage	V_{EB0}
Collector Current	I_C
Collector Peak Current ($t \leq 10\mu\text{s}$)	I_{CM}
Base Current	I_B
Total Power Dissipation @ $T_{CC}25^\circ\text{C}$	P_{tot}
Junction Temperature	T_j
Storage Temperature Range	T_{stg}

BD 533	BD 535	BD 537
45V	60V	80V
45V	60V	80V
	5V	
	4A	
	8A	
	1A	
	50W	
	150°C	
	-55 to +150°C	

THERMAL RESISTANCE

Junction to Case	θ_{jc}	2.5°C/W	max.
Junction to Ambient	θ_{ja}	70°C/W	max.

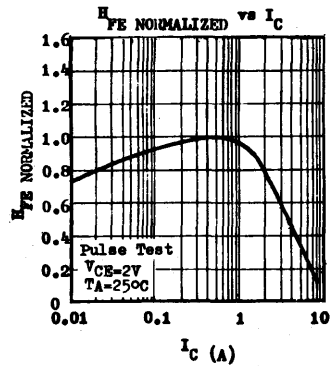
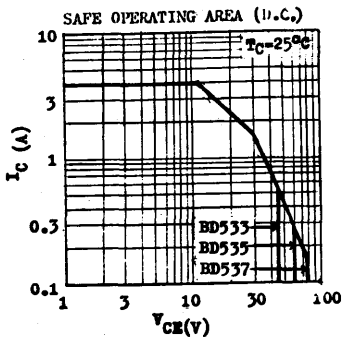

BD533 BD535 BD537

ELECTRICAL CHARACTERISTICS ($T_A=25^{\circ}\text{C}$ unless otherwise noted)

PARAMETER	SYMBOL	MIN	TYP	MAX	UNIT	TEST CONDITIONS
Collector-Base Breakdown Voltage	BV _{CB0}	45			V	I _C =0.1mA I _E =0
BD 533		60			V	
BD 535		80			V	
Collector-Base Breakdown Voltage	LV _{CE0} *	45			V	I _C =100mA I _B =0
BD 533		60			V	
BD 535		80			V	
Emitter-Base Breakdown Voltage	BV _{EB0}	5			V	I _E =0.1mA I _C =0
BD 533, BD 535, BD 537						
Collector Cutoff Current	I _{CBO}			100	μA	V _{CB} =45V I _E =0
BD 533				100	μA	V _{CB} =60V I _E =0
BD 535				100	μA	V _{CB} =80V I _E =0
Collector Cutoff Current	I _{CES}			100	μA	V _{CE} =45V V _{BE} =0
BD 533, BD 535, BD 537						
Emitter Cutoff Current	I _{EB0}			100	μA	V _{EB} =5V I _C =0
Collector-Emitter Saturation Voltage	V _{CE(sat)} *	0.27	0.8		V	I _C =2A I _B =0.2A
			0.8			V
Base-Emitter Voltage	V _{BE} *	0.92	1.5		V	I _C =2A V _{CE} =2V
D.C. Current Gain	H _{FE} *	20				I _C =10mA V _{CE} =5V
BD 533		20				
BD 535		15				
BD 537		25				I _C =2A V _{CE} =2V
BD 533		25				
BD 535		15				
All types	40				I _C =500mA V _{CE} =2V	
Current Gain-Bandwidth Product	f _T	3			MHz	I _C =250mA V _{CE} =1V

* Pulse Test : Pulse Width=0.3mS, Duty Cycle=1%

BD534 BD536 BD538

PNP SILICON EPITAXIAL BASE POWER TRANSISTORS

THE BD 534, BD 536 AND BD 538 ARE PNP SILICON EPITAXIAL BASE POWER TRANSISTORS DESIGNED FOR SWITCHING, DRIVER AND OUTPUT STAGES IN AUDIO AMPLIFIERS. THE BD 534, BD 536 AND BD 538 ARE COMPLEMENTARY TO BD 533, BD 535 AND BD 537 RESPECTIVELY.

CASE TO-220B



ABSOLUTE MAXIMUM RATINGS

		BD 534	BD 536	BD 538
Collector-Base Voltage	-V _{CB0}	45V	60V	80V
Collector-Emitter Voltage	-V _{CE0}	45V	60V	80V
Emitter-Base Voltage	-V _{EB0}		5V	
Collector Current	-I _C		4A	
Collector Peak Current (t < 10ms)	-I _{CM}		8A	
Base Current	-I _B		1A	
Total Power Dissipation @ T _C < 25°C	P _{tot}		50W	
Junction Temperature	T _j		150°C	
Storage Temperature Range	T _{atg}		-55 to +150°C	

THERMAL RESISTANCE

Junction to Case	θ _{jc}	2.50°C/W	max.
Junction to Ambient	θ _{ja}	700°C/W	max.

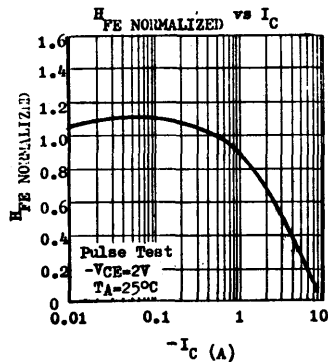
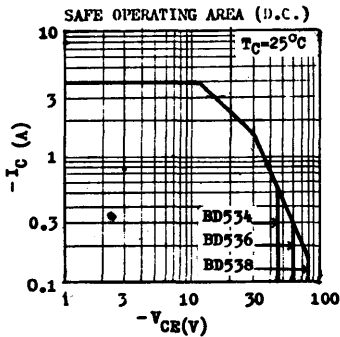

BD534 BD536 BD538

ELECTRICAL CHARACTERISTICS (TA=25°C unless otherwise noted)

PARAMETER	SYMBOL	MIN	TYP	MAX	UNIT	TEST CONDITIONS
Collector-Base Breakdown Voltage	-BV _{CB0}					-I _C =0.1mA I _B =0
BD 534		45			V	
BD 536		60			V	
BD 538		80			V	
Collector-Emitter Breakdown Voltage	-LV _{CE0} *					-I _C =100mA I _B =0
BD 534		45			V	
BD 536		60			V	
BD 538		80			V	
Emitter-Base Breakdown Voltage	-BV _{EB0}					-I _E =0.1mA I _C =0
BD 534, BD 536, BD 538		5			V	
Collector Cutoff Current	-I _{CBO}					
BD 534				100	μA	-V _{CB} =45V I _E =0
BD 536				100	μA	-V _{CB} =60V I _E =0
BD 538				100	μA	-V _{CB} =80V I _E =0
Collector Cutoff Current	-I _{CES}					
BD 534				100	μA	-V _{CE} =45V V _{BE} =0
BD 536				100	μA	
BD 538				100	μA	
Emitter Cutoff Current	-I _{EB0}			100	μA	-V _{EB} =5V I _C =0
Collector-Emitter Saturation Voltage	-V _{CE(sat)} *	0.3	0.8		V	-I _C =2A -I _B =0.2A
		0.8			V	-I _C =6A -I _B =0.6A
Base-Emitter Voltage	-V _{BE} *	0.95	1.5		V	-I _C =2A -V _{CE} =2V
D.C. Current Gain	H _{FE} *	20				-I _C =10mA -V _{CE} =5V
		20				
		15				
		25				-I _C =2A -V _{CE} =2V
		25				
		15				
	All types	40				-I _C =500mA -V _{CE} =2V
Current Gain-Bandwidth Product	f _T	3			MHz	-I _C =250mA -V _{CE} =1V

* Pulse Test : Pulse Width=0.3ms, Duty Cycle=1%

BD633 through BD638

COMPLEMENTARY SILICON EPITAXIAL BASE AF POWER TRANSISTORS

THE BD633 THROUGH BD638 ARE SILICON EPITAXIAL BASE POWER TRANSISTORS DESIGNED FOR SWITCHING, DRIVER AND OUTPUT STAGES IN AUDIO AMPLIFIERS. THE BD633, BD635, BD637 ARE NPN AND ARE COMPLEMENTARY TO THE PNP TYPE BD634, BD636, BD638.

CASE TO-220B



ABSOLUTE MAXIMUM RATINGS

For p-n-p devices, voltage and current values are negative

		BD633(NPN) BD634(PNP)	BD635(NPN) BD636(PNP)	BD637(NPN) BD638(PNP)
Collector-Base Voltage	V _{CB0}	45V	60V	100V
Collector-Emitter Voltage	V _{CE0}	45V	60V	80V
Emitter-Base Voltage	V _{EB0}	5V	5V	5V
Collector Current	I _C	2A	2A	2A
Collector Peak Current	I _{CM}	5A	5A	5A
Total Power Dissipation (T _C ≤ 25°C)	P _{tot}	30W		
		(T _A ≤ 25°C) 2W		
Operating Junction & Storage Temperature	T _j , T _{stg}	-55 to 150°C		

THERMAL RESISTANCE

Junction to Case	θ _{jc}	4.17°C/W max.
Junction to Ambient	θ _{ja}	62.5°C/W max

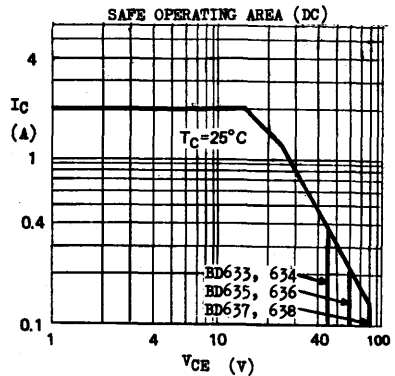
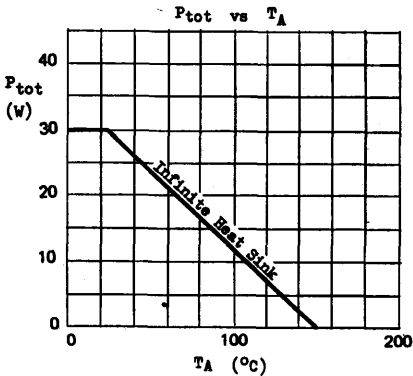

BD633 through BD638

ELECTRICAL CHARACTERISTICS ($T_A=25^\circ\text{C}$ unless otherwise noted)

PARAMETER	SYMBOL	MIN	MAX	UNIT	TEST CONDITIONS
Collector-Base Breakdown Voltage	V _{CB0}	45		V	I _C =0.1mA I _B =0
BD633, 634		60		V	
BD635, 636 BD637, 638		100		V	
Collector-Emitter Breakdown Voltage	V _{CE0} *	45		V	I _C =30mA I _B =0
BD633, 634		60		V	
BD635, 636 BD637, 638		80		V	
Emitter-Base Breakdown Voltage	V _{EB0}	5		V	I _B =1mA I _C =0
Collector Cutoff Current	I _{CES}		0.2	mA	V _{CE} =45V V _{BE} =0
BD633, 634			0.2	mA	V _{CE} =60V V _{BE} =0
BD635, 636 BD637, 638			0.2	mA	V _{CE} =100V V _{BE} =0
Collector-Emitter Saturation Voltage	V _{CE(sat)} *		0.6	V	I _C =1A I _B =0.1A
Base-Emitter Voltage	V _{BE} *		1.3	V	I _C =1A V _{CE} =2V
D.C. Current Gain	h _{FE} *	40			I _C =25mA V _{CE} =2V
		25			I _C =1A V _{CE} =2V
Current Gain-Bandwidth Product	f _T	3		MHz	I _C =0.2A V _{CE} =10V

* Pulse Test : Pulse Width=0.3ms, Duty Cycle=1%

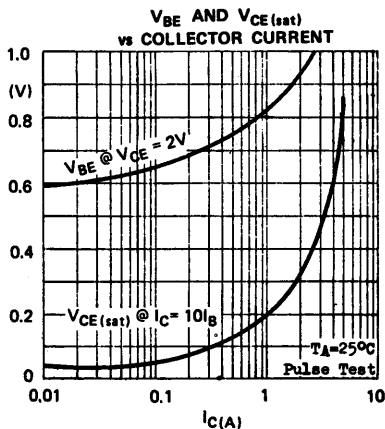
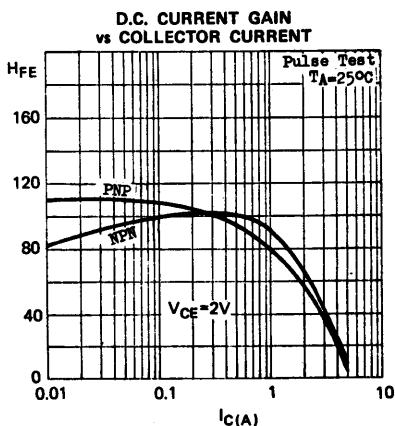

BF158 BF159 BF160

NPN SILICON RF SMALL SIGNAL TRANSISTORS

THE BF158, BF159, BF160 ARE NPN SILICON PLANAR EPITAXIAL TRANSISTORS FOR RF SMALL SIGNAL APPLICATIONS SUCH AS RF-IF AMPLIFIERS IN FM RECEIVERS AND TRIO VIDEO IF AMPLIFIERS IN TV RECEIVERS.

CASE T0-106



ABSOLUTE MAXIMUM RATINGS

Collector-Base Voltage	VCBO	
Collector-Emitter Voltage	VCEO	
Emitter-Base Voltage	VEBO	
Collector Current	IC	
Total Power Dissipation (TA < 25°C)	Ptot	
Operating Junction & Storage Temperature	Tj, Tstg	

	BF158	BF159	BF160
VCBO	30V	40V	30V
VCEO	12V	20V	12V
VEBO	2V	2V	2V
IC		50mA	
Ptot		200mW	
derate	2mW/°C above 25°C		
	-55 to 125°C		

ELECTRICAL CHARACTERISTICS (TA=25°C unless otherwise noted)

PARAMETER	SYMBOL	MIN	TYP	MAX	UNIT	TEST CONDITIONS
Collector-Base Breakdown Voltage BF158, BF160 BF159	BVCBO	30		40	V	IC=0.1mA IE=0
Collector-Emitter Breakdown Voltage BF158, BF160 BF159	LVCEO	12		20	V	IC=3mA (pulsed) IE=0
Emitter-Base Breakdown Voltage All types	BVEBO	2			V	IE=0.1mA IC=0
Collector Cutoff Current All types	ICBO		100	5	nA µA	VCE=15V IE=0 VCB=15V IE=0 TA=65°C
Collector-Emitter Saturation Voltage All types	VCE(sat)		0.1	0.5	V	IC=10mA IE=1mA
D.C. Current Gain BF158, BF159 BF160	hFE	20	70	70		IC=4mA VCE=10V IC=3mA VCE=10V
Current Gain-Bandwidth Product BF158, BF159 BF160	fT	400	700	600	MHz	IC=5mA VCE=10V IC=3mA VCE=10V
Feedback Capacitance BF158, BF159 BF160	Cre	0.8	1.2	1.2	pF	IC=5mA VCE=10V f=1MHz IC=3mA VCE=10V f=1MHz
Power Gain BF158, BF159 BF160	Gpe	22	26	32	dB	IC=5mA VCE=10V f=40MHz IC=3mA VCE=8V f=10.7MHz
Output Conductance BF158 only	Soe	0.2	0.3		mU	IC=5mA VCE=10V f=40MHz
Noise Figure All types	NF		3.5		dB	IC=4mA VCE=10V RQ=400Ω f=40MHz

BF158 BF159 BF160

TYPICAL CHARACTERISTICS AT $T_A=25^\circ\text{C}$

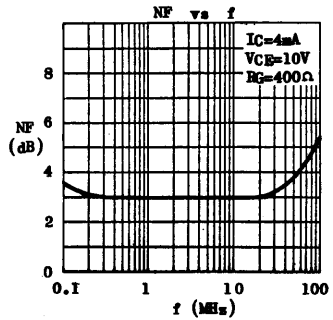
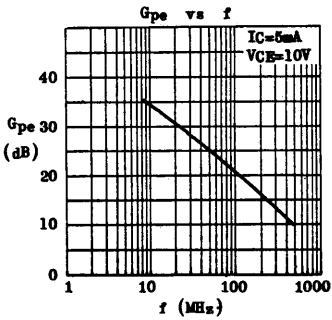
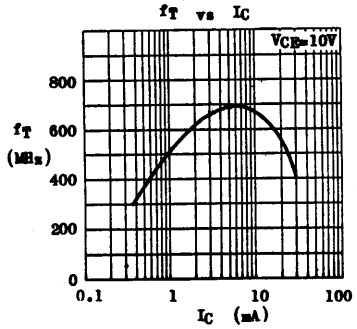
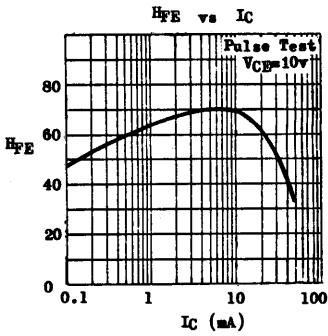

BF254 BF255

NPN SILICON RF SMALL SIGNAL TRANSISTORS

THE BF254, BF255 ARE NPN SILICON PLANAR EPITAXIAL TRANSISTORS. THE BF254 IS INTENDED FOR USE IN AM/FM IF AMPLIFIERS AND FOR INPUT STAGES IN THE SHORT, MEDIUM AND LONG WAVE BANDS. THE BF255 IS INTENDED FOR USE IN PRE-STAGES AND CONVERTER STAGES IN THE VHF BAND.

CASE TO-92E



CBE

ABSOLUTE MAXIMUM RATINGS

		<u>BF254</u>	<u>BF255</u>
Collector-Base Voltage	V _{CB0}	30V	30V
Collector-Emitter Voltage	V _{CE0}	20V	20V
Emitter-Base Voltage	V _{EB0}	5V	5V
Collector Current	I _C	30mA	
Total Power Dissipation (T _A ≤ 25°C)	P _{tot}	300mW	
		derate 3mW/°C above 25°C	
Operating Junction & Storage Temperature	T _j , T _{stg}	-55 to 125°C	

ELECTRICAL CHARACTERISTICS (T_A=25°C unless otherwise noted)

PARAMETER	SYMBOL	BF254		BF255		UNIT	TEST CONDITIONS
		MIN	TYP MAX	MIN	TYP MAX		
Emitter-Base Breakdown Voltage	V _{EB0}	5		5		V	I _E =10μA I _C =0
Collector Cutoff Current	I _{CB0}		0.1		0.1	μA	V _{CB} =30V I _E =0
Collector Cutoff Current	I _{CE0}		1		1	μA	V _{CE} =20V I _B =0
Collector-Emitter Saturation Voltage	V _{CE(sat)}	0.1		0.1		V	I _C =10mA I _B =1mA
Base-Emitter Voltage	V _{BE}	0.67	0.74	0.67	0.74	V	I _C =1mA V _{CE} =10V
D.C. Current Gain	h _{FE}	67	115 220	36	67 125		I _C =1mA V _{CE} =10V
Current Gain-Bandwidth Product	f _T	260		200		MHz	I _C =1mA V _{CE} =10V
Feedback Time Constant	C _{o'fbb'}	25	40	20	35	pS	I _C =1mA V _{CE} =5V f=31.8MHz
Feedback Capacitance	C _{re}	0.85		0.85		pF	I _C =1mA V _{CE} =10V f=450KHz
Noise Figure	NF	4		4		dB	I _C =1mA V _{CE} =10V R _G =100Ω f=100MHz

BF254 BF255

BF254 TYPICAL y-PARAMETERS AT $T_A=25^\circ\text{C}$ $I_C=1\text{mA}$ $V_{CE}=10\text{V}$

f=450kHz Common Emitter	$g_{11}=0.33\text{m}\Omega$	$ y_{12} =2.8\mu\text{S}$	$ y_{21} =36\text{m}\Omega$	$g_{22}=6\mu\text{S}$
	$b_{11}=0.065\text{m}\Omega$	$-g_{12}=-90^\circ$	$-g_{21}=-0^\circ$	$b_{22}=4.5\mu\text{S}$
	$C_{11}=23\text{pF}$			$C_{22}=1.6\text{pF}$
f=10.7MHz Common Emitter	$g_{11}=0.45\text{m}\Omega$	$ y_{12} =65\mu\text{S}$	$ y_{21} =36\text{m}\Omega$	$g_{22}=8.5\mu\text{S}$
	$b_{11}=1.5\text{m}\Omega$	$-g_{12}=-90^\circ$	$-g_{21}=-10^\circ$	$b_{22}=0.11\text{m}\Omega$
	$C_{11}=22\text{pF}$			$C_{22}=1.6\text{pF}$
f=100MHz Common Base	$g_{11}=36\text{m}\Omega$	$ y_{12} =420\mu\text{S}$	$ y_{21} =33\text{m}\Omega$	$g_{22}=22\mu\text{S}$
	$-b_{11}=3\text{m}\Omega$	$-g_{12}=-88^\circ$	$-g_{21}=-146^\circ$	$b_{22}=1.1\text{m}\Omega$
	$-C_{11}=4.8\text{pF}$			$C_{22}=1.75\text{pF}$

BF255 TYPICAL y-PARAMETERS AT $T_A=25^\circ\text{C}$ $I_C=1\text{mA}$ $V_{CE}=10\text{V}$

f=450kHz Common Emitter	$g_{11}=0.5\text{m}\Omega$	$ y_{12} =2.6\mu\text{S}$	$ y_{21} =36\text{m}\Omega$	$g_{22}=2.7\mu\text{S}$
	$b_{11}=0.1\text{m}\Omega$	$-g_{12}=-90^\circ$	$-g_{21}=-0^\circ$	$b_{22}=4.5\mu\text{S}$
	$C_{11}=32\text{pF}$			$C_{22}=1.6\text{pF}$
f=10.7MHz Common Emitter	$g_{11}=0.6\text{m}\Omega$	$ y_{12} =60\mu\text{S}$	$ y_{21} =36\text{m}\Omega$	$g_{22}=4.5\mu\text{S}$
	$b_{11}=2\text{m}\Omega$	$-g_{12}=-90^\circ$	$-g_{21}=-10^\circ$	$b_{22}=0.11\text{m}\Omega$
	$C_{11}=30\text{pF}$			$C_{22}=1.6\text{pF}$
f=100MHz Common Base	$g_{11}=38\text{m}\Omega$	$ y_{12} =410\mu\text{S}$	$ y_{21} =34\text{m}\Omega$	$g_{22}=12\mu\text{S}$
	$-b_{11}=1\text{m}\Omega$	$-g_{12}=-85^\circ$	$-g_{21}=-140^\circ$	$b_{22}=1.1\text{m}\Omega$
	$-C_{11}=1.6\text{pF}$			$C_{22}=1.75\text{pF}$

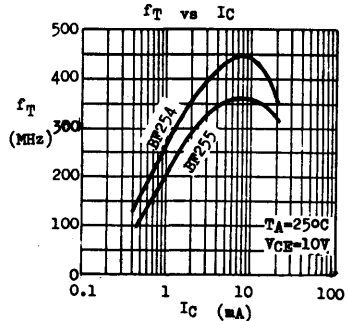
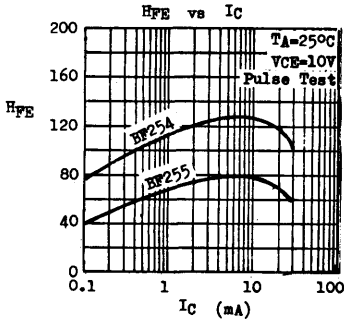

BF257 BF258 BF259

NPN HIGH VOLTAGE VIDEO AMPLIFIERS

THE BF257, BF258, BF259 ARE NPN SILICON PLANAR TRANSISTORS DESIGNED FOR HIGH VOLTAGE VIDEO OUTPUT STAGES IN BLACK-AND-WHITE AND COLOUR TV-RECEIVERS.

CASE TO-39



ABSOLUTE MAXIMUM RATINGS

		BF257	BF258	BF259
Collector-Base Voltage	V _{CB0}	160V	250V	300V
Collector-Emitter Voltage	V _{CE0}	160V	250V	300V
Emitter-Base Voltage	V _{EB0}		5V	
Collector Current	I _C		100mA	
Total Power Dissipation @ T _C ≤ 25°C	P _{tot}		5W	
			800mW	
Operating Junction & Storage Temperature	T _j , T _{stg}	-65 to 200°C		

THERMAL RESISTANCE

Junction to Case	θ _{jc}	35°C/W	max.
Junction to Ambient	θ _{ja}	220°C/W	max.

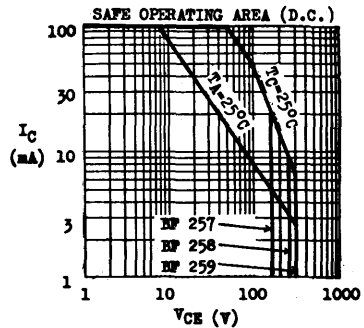
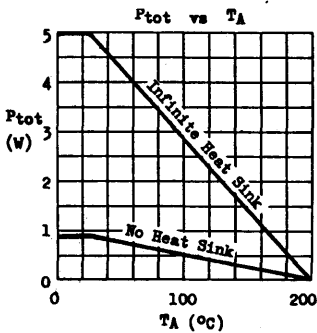

BF257 BF258 BF259

ELECTRICAL CHARACTERISTICS (T_A=25°C unless otherwise noted)

PARAMETER	SYMBOL	BF257		BF258		BF259		UNIT	TEST CONDITIONS
		MIN	MAX	MIN	MAX	MIN	MAX		
Collector-Base Breakdown Voltage	BV_{CBO}	160	250	300	300	300		V	$I_C=0.1mA$ $I_E=0$
Collector-Emitter Breakdown Voltage	BV_{CEO}^*	160	250	300	300	300		V	$I_C=10mA$ $I_B=0$
Emitter-Base Breakdown Voltage	BV_{EBO}	5	5	5	5	5		V	$I_E=0.1mA$ $I_C=0$
Collector Cutoff Current	I_{CBO}	50	50	50	50	50		nA	$V_{CB}=100V$ $I_E=0$
								nA	$V_{CB}=200V$ $I_E=0$
								nA	$V_{CB}=250V$ $I_E=0$
Emitter Cutoff Current	I_{EBO}	50	50	50	50	50		nA	$V_{EB}=3V$ $I_C=0$
D.C. Current Gain	H_{FE}^*	25	25	25	25	25			$I_C=30mA$ $V_{CE}=10V$
Collector-Emitter Saturation Voltage	$V_{CE(sat)}^*$	1	1	1	1	1		V	$I_C=30mA$ $I_B=6mA$
Current Gain-Bandwidth Product	f_T	50	50	50	50	50		MHz	$I_C=15mA$ $V_{CE}=20V$
Collector-Base Capacitance	C_{cb}	5	5	5	5	5		pF	$V_{CB}=30V$ $I_E=0$ $f=1MHz$

* Pulse Test : Pulse Width=0.3ms, Duty Cycle=1%

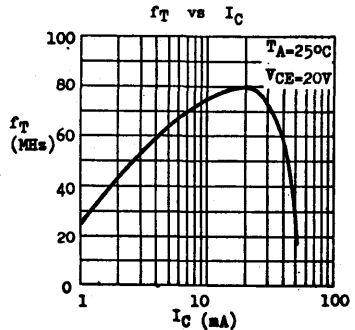
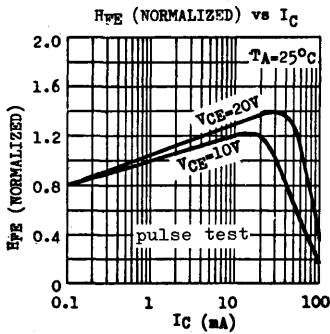

BF297 BF298 BF299

NPN HIGH VOLTAGE VIDEO AMPLIFIERS

THE BF297, BF298, BF299 ARE NPN SILICON PLANAR TRANSISTORS DESIGNED FOR HIGH VOLTAGE VIDEO AMPLIFIERS IN TELEVISION RECEIVERS. THEY FEATURE GOOD FREQUENCY CHARACTERISTICS.

CASE TO-92F



ABSOLUTE MAXIMUM RATINGS

		BF297	BF298	BF299
Collector-Base Voltage	V_{CBO}	160V	250V	300V
Collector-Emitter Voltage	V_{CEO}	160V	250V	300V
Emitter-Base Voltage	V_{EBO}		5V	
Collector Current	I_C		100mA	
Total Power Dissipation • $T_C \leq 25^\circ\text{C}$ • $T_A \leq 25^\circ\text{C}$	P_{tot}		1.5W	625mW
Operating Junction & Storage Temperature	T_j & T_{stg}		-55 to 150°C	

ELECTRICAL CHARACTERISTICS ($T_A = 25^\circ\text{C}$ unless otherwise noted)

PARAMETER	SYMBOL	BF297		BF298		BF299		UNIT	TEST CONDITIONS
		MIN	MAX	MIN	MAX	MIN	MAX		
Collector-Base Breakdown Voltage	V_{CBO}	160		250		300		V	$I_C = 0.1\text{mA}$ $I_E = 0$
Collector-Emitter Breakdown Voltage	V_{CEO}	160		250		300		V	$I_C = 10\text{mA}$ $I_B = 0$
Emitter-Base Voltage	V_{EBO}	5		5		5		V	$I_E = 0.1\text{mA}$ $I_C = 0$
Collector Cutoff Current	I_{CBO}		50					nA	$V_{CB} = 100\text{V}$ $I_E = 0$
					50			nA	$V_{CB} = 200\text{V}$ $I_E = 0$
						50		nA	$V_{CB} = 250\text{V}$ $I_E = 0$
Emitter Cutoff Current	I_{EBO}		50		50		50	nA	$V_{EB} = 3\text{V}$ $I_C = 0$
Collector-Emitter Saturation Voltage	$V_{CE(sat)}$		1		1		1	V	$I_C = 30\text{mA}$ $I_B = 3\text{mA}$
Base-Emitter Saturation Voltage	$V_{BE(sat)}$		0.85		0.85		0.85	V	$I_C = 30\text{mA}$ $I_B = 3\text{mA}$
D.C. Current Gain	h_{FE}	10		10		10			$I_C = 5\text{mA}$ $V_{CE} = 10\text{V}$
		30	150	30	150	30	150		$I_C = 30\text{mA}$ $V_{CE} = 10\text{V}$
		10		10		10			$I_C = 100\text{mA}$ $V_{CE} = 10\text{V}$
Current Gain-Bandwidth Product	f_T	50		50		50		MHz	$I_C = 30\text{mA}$ $V_{CE} = 10\text{V}$
Collector-Base Capacitance	C_{ob}		5		5		5	pF	$V_{CB} = 30\text{V}$ $I_E = 0$ $f = 1\text{MHz}$

BF297 BF298 BF299

TYPICAL CHARACTERISTICS ($T_A=25^\circ\text{C}$ unless otherwise noted)

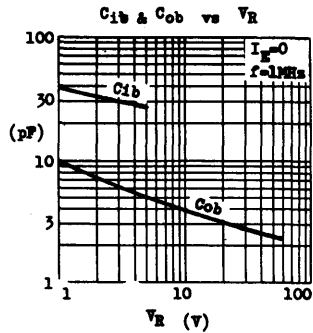
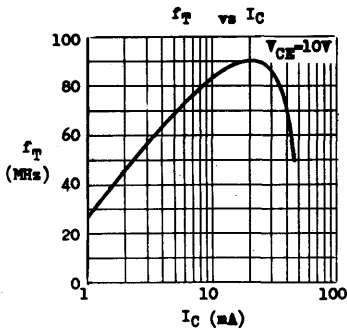
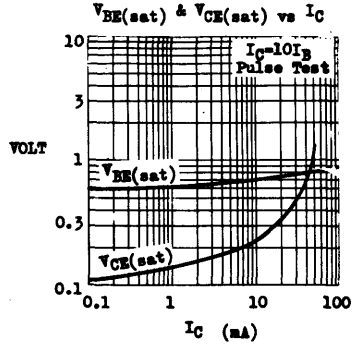
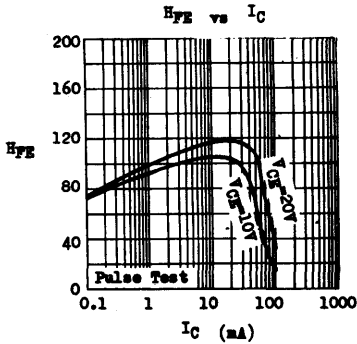
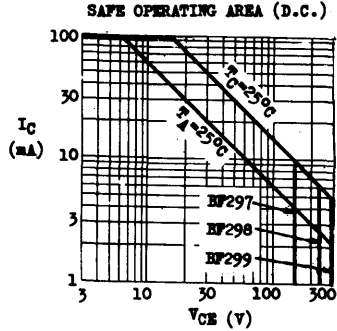
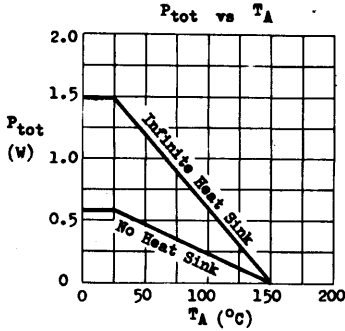

BF336 BF337 BF338

NPN HIGH VOLTAGE VIDEO AMPLIFIERS

THE BF336, BF337, BF338 ARE NPN SILICON PLANAR TRANSISTORS DESIGNED FOR R-G-B AND COLOUR DIFFERENCE OUTPUT CIRCUITS OF COLOUR TELEVISION RECEIVERS. THEY FEATURE HIGH BREAKDOWN VOLTAGE AND GOOD FREQUENCY CHARACTERISTICS.

CASE TO-39



C E B

ABSOLUTE MAXIMUM RATINGS

		<u>BF336</u>	<u>BF337</u>	<u>BF338</u>
Collector-Emitter Voltage ($I_{BE}=1\text{mA}$)	V_{CE}	185V	250V	300V
Collector-Emitter Voltage ($I_B=0$)	V_{CEO}	180V	200V	225V
Emitter-Base Voltage	V_{EB0}		5V	
Collector Current	I_C		100mA	
Total Power Dissipation @ $T_C \leq 25^\circ\text{C}$	P_{tot}		5W	
@ $T_A \leq 25^\circ\text{C}$			800mW	
Operating Junction & Storage Temperature	T_j & T_{stg}		-65 to 200°C	

THERMAL RESISTANCE

Junction to Case	θ_{jc}	35°C/W	max.
Junction to Ambient	θ_{ja}	220°C/W	max.

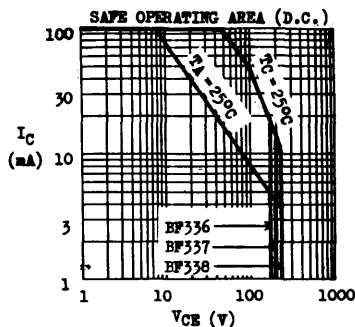
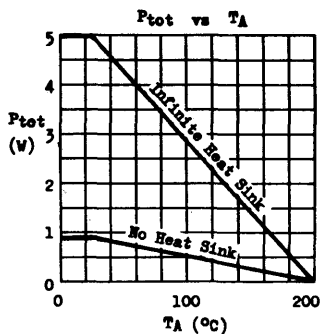

BF336 BF337 BF338

ELECTRICAL CHARACTERISTICS ($T_A=25^\circ\text{C}$ unless otherwise noted)

PARAMETER	SYMBOL	BF336		BF337		BF338		UNIT	TEST CONDITIONS
		MIN	MAX	MIN	MAX	MIN	MAX		
Collector-Base Breakdown Voltage	V_{CB0}	185	250	250	300	300		V	$I_C=0.1\text{mA}$ $I_E=0$
Collector-Emitter Breakdown Voltage	V_{CE0}^*	185	250	250	300	300		V	$I_C=1\text{mA}$ $R_{BE}=1\text{k}\Omega$ $T_J \leq 150^\circ\text{C}$
Collector-Emitter Breakdown Voltage	V_{CE0}^*	180	200	200	225	225		V	$I_C=4\text{mA}$ $I_B=0$
Emitter-Base Breakdown Voltage	V_{EB0}	5	5	5	5	5		V	$I_E=0.1\text{mA}$ $I_C=0$
Collector Cutoff Current	I_{CER}	100		100		100		μA	$V_{CE}=150\text{V}$ $R_{BE}=1\text{k}\Omega$
								μA	$V_{CE}=200\text{V}$ $R_{BE}=1\text{k}\Omega$
								μA	$V_{CE}=250\text{V}$ $R_{BE}=1\text{k}\Omega$
Base-Emitter Voltage	V_{BE}^*	1.2	1.2	1.2	1.2	1.2		V	$I_C=30\text{mA}$ $V_{CE}=10\text{V}$
D.C. Current Gain	H_{FE}^*	20	20	20	20	20			$I_C=30\text{mA}$ $V_{CE}=10\text{V}$
Current Gain-Bandwidth Product	f_T	50	50	50	50	50		MHz	$I_C=30\text{mA}$ $V_{CE}=20\text{V}$
Feedback Capacitance	C_{re}	3.5	3.5	3.5	3.5	3.5		pF	$I_C=10\text{mA}$ $V_{CE}=20\text{V}$ $f=0.5\text{MHz}$
Feedback Time Constant	Corbb'	100	100	100	100	100		pS	$I_E=30\text{mA}$ $V_{CB}=20\text{V}$ $f=10\text{MHz}$

* Pulse Test : Pulse Width=0.3mS, Duty Cycle=1%

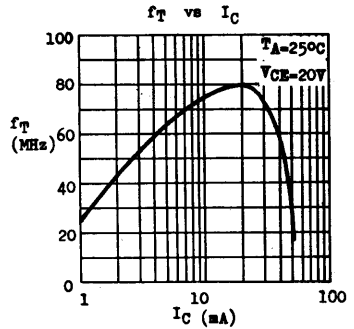
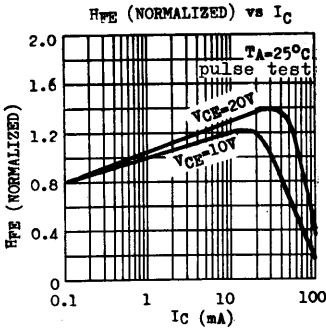

BF368 BF369

NPN SILICON RF SMALL SIGNAL TRANSISTORS

THE BF368, BF369 ARE NPN SILICON PLANAR EPITAXIAL TRANSISTORS FOR RF-IF SMALL SIGNAL AMPLIFIER AND OSCILLATOR APPLICATIONS.

CASE TO-92A



EBC

ABSOLUTE MAXIMUM RATINGS

		BF368	BF369
Collector-Base Voltage	V _{CB0}	25V	30V
Collector-Emitter Voltage	V _{CE0}	15V	20V
Emitter-Base Voltage	V _{EB0}	4V	4V
Collector Current	I _C	50mA	
Total Power Dissipation (T _A ≤ 25°C)	P _{tot}	310mW	
		derate 2.81mW/°C above 25°C	
Operating Junction & Storage Temperature	T _j , T _{stg}	-55 to 135°C	

ELECTRICAL CHARACTERISTICS (T_A = 25°C)

PARAMETER	SYMBOL	BF368			BF369			UNIT	TEST CONDITIONS
		MIN	TYP	MAX	MIN	TYP	MAX		
Collector-Base Breakdown Voltage	V _{CB0}	25			30			V	I _C =0.1mA I _B =0
Collector-Emitter Breakdown Voltage	V _{CE0} *	15			20			V	I _C =3mA I _B =0
Emitter-Base Breakdown Voltage	V _{EB0}	4			4			V	I _B =0.01mA I _C =0
Collector Cutoff Current	I _{CB0}			100			100	mA	V _{CB} =15V I _B =0
Collector-Emitter Saturation Voltage	V _{CE(sat)}	0.12	0.4		0.1	0.4		V	I _C =10mA I _B =1mA
Base-Emitter Saturation Voltage	V _{BE(sat)}	0.84	1.0		0.84	1.0		V	I _C =10mA I _B =1mA
D.C. Current Gain	h _{FE}	35	60	125	70	110	220		I _C =1mA V _{CE} =10V
Current Gain-Bandwidth Product	f _T	250	400		400	520		MHz	I _C =1mA V _{CE} =10V
Output Capacitance	C _{ob}		1.3	1.7		1.3	1.7	pF	V _{CB} =10V I _B =0 f=1MHz
Collector-Base Time Constant	C _{crbb'}		20			25		pS	I _C =1mA V _{CB} =5V f=31.8MHz

* Pulse Test : Pulse Width=0.3ms, Duty Cycle=1%

TYPICAL CHARACTERISTICS AT $T_A=25^\circ\text{C}$

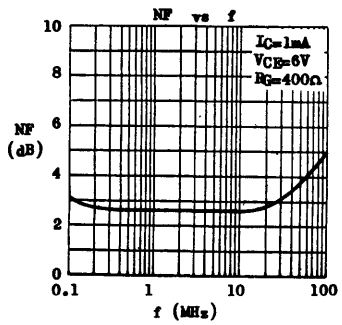
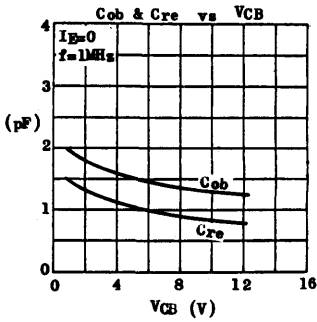
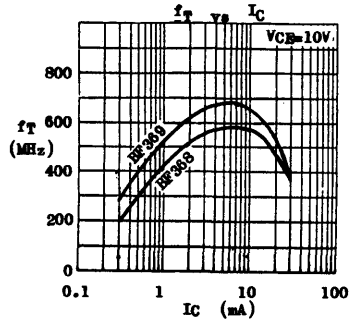
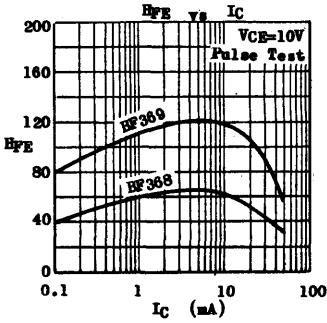

TYPICAL COMMON BASE y -PARAMETERS AT $f=100\text{MHz}$ $V_{CB}=5\text{V}$ $T_A=25^\circ\text{C}$

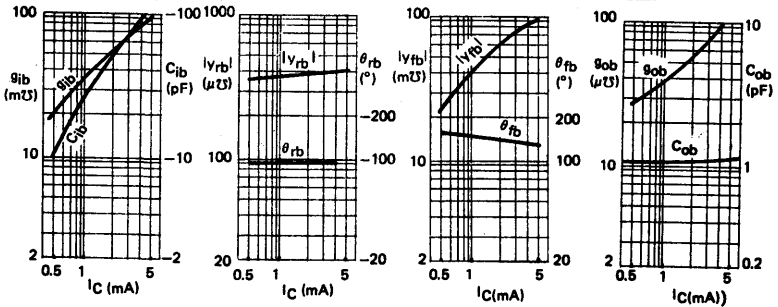

BF391 BF392 BF393

NPN HIGH VOLTAGE VIDEO AMPLIFIERS

THE BF391, BF392, BF393 ARE NPN SILICON PLANAR TRANSISTORS DESIGNED FOR HIGH VOLTAGE VIDEO AMPLIFIERS IN TELEVISION RECEIVERS. THEY FEATURE 200V MINIMUM COLLECTOR-EMITTER BREAKDOWN VOLTAGE AND GOOD FREQUENCY CHARACTERISTICS.

CASE TC-92A



ABSOLUTE MAXIMUM RATINGS

		<u>BF391</u>	<u>BF392</u>	<u>BF393</u>
Collector-Base Voltage	V _{CB0}	200V	250V	300V
Collector-Emitter Voltage	V _{CE0}	200V	250V	300V
Emitter-Base Voltage	V _{EB0}	6V	8V	8V
Collector Current	I _{CM}		500mA	
Total Power Dissipation @ T _C < 25°C	P _{tot}		1.5W	
			625mW	
Operating Junction & Storage Temperature	T _j & T _{stg}		-55 to 150°C	

ELECTRICAL CHARACTERISTICS (T_A=25°C unless otherwise noted)

PARAMETER	SYMBOL	BF391		BF392		BF393		UNIT	TEST CONDITIONS
		MIN	MAX	MIN	MAX	MIN	MAX		
Collector-Base Breakdown Voltage	V _{CB0}	200		250		300		V	I _C =0.1mA I _B =0
Collector-Emitter Breakdown Voltage	V _{CE0}	200		250		300		V	I _C =1mA I _B =0
Emitter-Base Breakdown Voltage	V _{EB0}	6		8		8		V	I _E =0.1mA I _C =0
Collector Cutoff Current	I _{CB0}		0.1					μA	V _{CB} =160V I _B =0
					0.1	0.1		μA	V _{CB} =200V I _B =0
Emitter Cutoff Current	I _{EB0}		0.1					μA	V _{EB} =4V I _C =0
					0.1	0.1		μA	V _{EB} =6V I _C =0
Collector-Emitter Saturation Voltage	V _{CE(sat)}		2		2		2	V	I _C =20mA I _B =2mA
Base-Emitter Saturation Voltage	V _{BE(sat)}		2		2		2	V	I _C =20mA I _B =2mA
D.C. Current Gain	h _{FE}	25		25		25			I _C =1mA V _{CE} =10V
		40		40		40			I _C =10mA V _{CE} =10V
Current Gain-Bandwidth Product	f _T	50		50		50		MHz	I _C =10mA V _{CE} =20V
Feedback Capacitance	C _{re}		2		2		2	pF	V _{CB} =60V I _B =0 f=1MHz

BF391 BF392 BF393

TYPICAL CHARACTERISTICS ($T_A=25^\circ\text{C}$ unless otherwise noted)

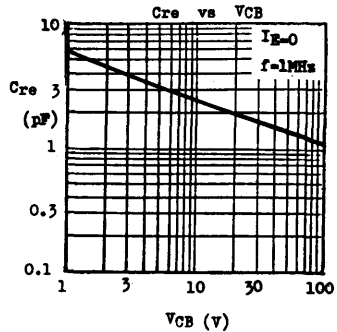
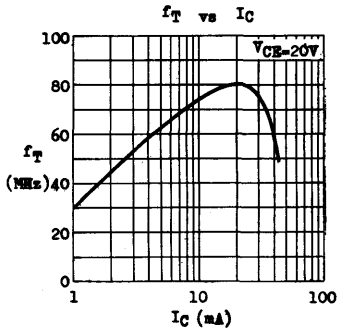
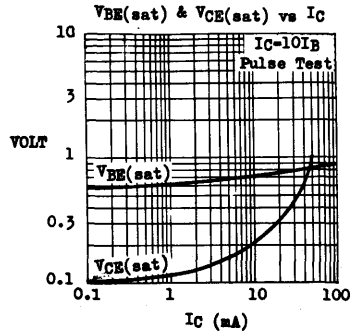
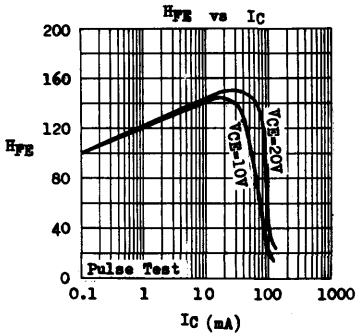
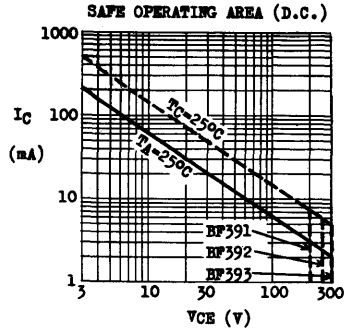
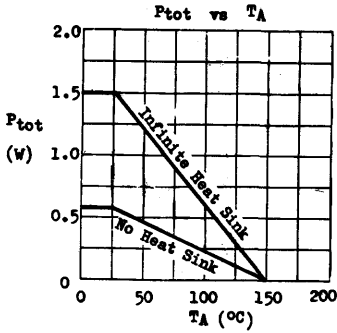

12.77.7300B

BF494 BF495

NPN SILICON RF SMALL SIGNAL TRANSISTORS

THE BF494, BF495 ARE NPN SILICON PLANAR EPITAXIAL TRANSISTORS FOR RF SMALL SIGNAL APPLICATIONS UP TO 100MHz.

CASE TO-92E



ABSOLUTE MAXIMUM RATINGS

		BF494	BF495
Collector-Base Voltage	V _{CB0}	30V	30V
Collector-Emitter Voltage	V _{CE0}	20V	20V
Emitter-Base Voltage	V _{EB0}	5V	5V
Collector Current	I _C	30mA	
Total Power Dissipation (T _A ≤ 75°C)	P _{tot}	300mW	
		derate 4mW/°C above 75°C	
Operating Junction & Storage Temperature	T _j , T _{stg}	-55 to 150°C	

ELECTRICAL CHARACTERISTICS (T_A = 25°C unless otherwise noted)

PARAMETER	SYMBOL	BF494			BF495			UNIT	TEST CONDITIONS
		MIN	TYP	MAX	MIN	TYP	MAX		
Emitter-Base Breakdown Voltage	V _{EB0}	5			5			V	I _B = 10μA I _C = 0
Collector Cutoff Current	I _{CB0}			0.1			0.1	μA	V _{CB} = 30V I _E = 0
Collector Cutoff Current	I _{CE0}			1			1	μA	V _{CE} = 20V I _B = 0
Collector-Emitter Saturation Voltage	V _{CE(sat)}		0.1			0.1		V	I _C = 10mA I _B = 1mA
Base-Emitter Voltage	V _{BE}	.65	.68	.74	.65	.68	.74	V	I _C = 1mA V _{CE} = 10V
D.C. Current Gain	h _{FE}	67	115	220	36	67	125		I _C = 1mA V _{CE} = 10V
Current Gain-Bandwidth Product	f _T		260			200		MHz	I _C = 1mA V _{CE} = 10V
Feedback Capacitance	C _{re}		.85			.85		pF	I _C = 1mA V _{CE} = 10V f = 450KHz
Noise Figure	N _F		4			4		dB	I _C = 1mA V _{CE} = 10V R _G = 100Ω f = 100MHz
Mixing Noise Figure	N _{Fc}		2					dB	I _C = 1mA V _{CE} = 10V R _G = 83Ω f = 1MHz
	N _{Fc}					2.5		dB	I _C = 1mA V _{CE} = 10V R _G = 67Ω f = 1MHz

BF494 BF495

BF494 TYPICAL y-PARAMETERS AT $T_A=25^\circ\text{C}$ $I_C=1\text{mA}$ $V_{CE}=10\text{V}$

f=450kHz Common Emitter	$S_{11} = 0.33\text{mV}$	$ y_{12} = 2.8\mu\text{V}$	$ y_{21} = 36\text{mV}$	$S_{22} = 6\mu\text{V}$
	$b_{11} = 0.065\text{mV}$	$-o_{12} = -90^\circ$	$-o_{21} = 0^\circ$	$b_{22} = 4.5\mu\text{V}$
	$C_{11} = 23\text{pF}$			$C_{22} = 1.6\text{pF}$
f=10.7MHz Common Emitter	$S_{11} = 0.45\text{mV}$	$ y_{12} = 65\mu\text{V}$	$ y_{21} = 36\text{mV}$	$S_{22} = 8.5\mu\text{V}$
	$b_{11} = 1.5\text{mV}$	$-o_{12} = -90^\circ$	$-o_{21} = -10^\circ$	$b_{22} = 0.11\text{mV}$
	$C_{11} = 22\text{pF}$			$C_{22} = 1.6\text{pF}$
f=100MHz Common Base	$S_{11} = 36\text{mV}$	$ y_{12} = 420\mu\text{V}$	$ y_{21} = 33\text{mV}$	$S_{22} = 22\mu\text{V}$
	$-b_{11} = 3\text{mV}$	$-o_{12} = -88^\circ$	$-o_{21} = -146^\circ$	$b_{22} = 1.1\text{mV}$
	$-C_{11} = 4.8\text{pF}$			$C_{22} = 1.75\text{pF}$

BF495 TYPICAL y-PARAMETERS AT $T_A=25^\circ\text{C}$ $I_C=1\text{mA}$ $V_{CE}=10\text{V}$

f=450kHz Common Emitter	$S_{11} = 0.5\text{mV}$	$ y_{12} = 2.6\mu\text{V}$	$ y_{21} = 36\text{mV}$	$S_{22} = 2.7\mu\text{V}$
	$b_{11} = 0.1\text{mV}$	$-o_{12} = -90^\circ$	$-o_{21} = 0^\circ$	$b_{22} = 4.5\mu\text{V}$
	$C_{11} = 32\text{pF}$			$C_{22} = 1.6\text{pF}$
f=10.7MHz Common Emitter	$S_{11} = 0.6\text{mV}$	$ y_{12} = 60\mu\text{V}$	$ y_{21} = 36\text{mV}$	$S_{22} = 4.5\mu\text{V}$
	$b_{11} = 2\text{mV}$	$-o_{12} = -90^\circ$	$-o_{21} = -10^\circ$	$b_{22} = 0.11\text{mV}$
	$C_{11} = 30\text{pF}$			$C_{22} = 1.6\text{pF}$
f=100MHz Common Base	$S_{11} = 36\text{mV}$	$ y_{12} = 410\mu\text{V}$	$ y_{21} = 34\text{mV}$	$S_{22} = 12\mu\text{V}$
	$-b_{11} = 1\text{mV}$	$-o_{12} = -85^\circ$	$-o_{21} = -140^\circ$	$b_{22} = 1.1\text{mV}$
	$-C_{11} = 1.6\text{pF}$			$C_{22} = 1.75\text{pF}$

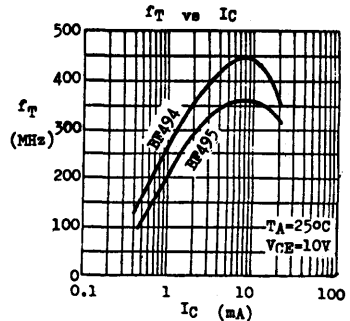
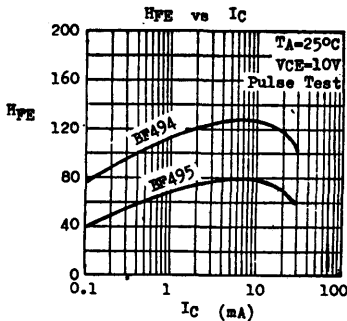

CL055 CL066

COMPLEMENTARY SILICON PLANAR LOW VCEK TRANSISTORS

THE CL055 (PNP) AND CL066 (NPN) ARE SILICON PLANAR EPITAXIAL COMPLEMENTARY PAIR SPECIALLY DESIGNED FOR 1-WATT AUDIO AMPLIFIER OUTPUT AND SWITCHING APPLICATIONS. THEY FEATURE LOW COLLECTOR-EMITTER KNEE VOLTAGE AND GOOD LINEARITY OF D.C. CURRENT GAIN.

CASE TO-92A X-67 Heat Sink

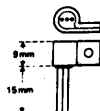

ABSOLUTE MAXIMUM RATINGS For p-n-p devices, voltage and current values are negative

Collector-Base Voltage	VCBO	25V
Collector-Emitter Voltage	VCEO	20V
Emitter-Base Voltage	VEBO	5V
Collector Current	IC	1A
Collector Peak Current ($t \leq 50\text{ms}$)	ICM	1.5A
Total Power Dissipation @ $T_C 25^\circ\text{C}$	Ptot	1.5W
With X-67 Heat Sink @ $T_A 25^\circ\text{C}$		800mW
Without Heat Sink @ $T_A 25^\circ\text{C}$		625mW
Operating Junction & Storage Temperature	T_j, T_{stg}	-55 to 150°C

ELECTRICAL CHARACTERISTICS ($T_A=25^\circ\text{C}$ unless otherwise noted)

PARAMETER	SYMBOL	MIN	TYP	MAX	UNIT	TEST CONDITIONS
Collector-Base Breakdown Voltage	VCBO	25			V	$I_C=100\mu\text{A}$ $I_B=0$
Collector-Emitter Breakdown Voltage	LVCEO *	20			V	$I_C=10\text{mA}$ $I_B=0$
Collector-Emitter Cutoff Current	ICES		0.5		μA	$V_{CE}=20\text{V}$ $V_{BE}=0$
Emitter-Base Cutoff Current	IEBO		1.0		μA	$V_{EB}=5\text{V}$ $I_C=0$
Collector-Emitter Knee Voltage	VCEK	0.25	0.5		V	$I_C=0.2\text{A}$ $I_B=\text{value at which } I_C=0.22\text{A}$ $V_{CE}=1\text{V}$
Collector-Emitter Saturation Voltage	VCE(sat)*	0.21	0.4		V	$I_C=0.5\text{A}$ $I_B=0.05\text{A}$
Base-Emitter Voltage	VBE *	0.87	1.2		V	$I_C=0.5\text{A}$ $V_{CE}=1\text{V}$
D.C. Current Gain (Note)	HFE 1 *	50	160	360		$I_C=0.1\text{A}$ $V_{CE}=1\text{V}$
	HFE 2 *	20	80			$I_C=1\text{A}$ $V_{CE}=2\text{V}$
Current Gain-Bandwidth Product	f_T	120			MHz	$I_C=50\text{mA}$ $V_{CE}=10\text{V}$

Note : HFE 1 is classified as follows.

Group A : 50-100

Group B : 80-160

Group C : 120-240

Group D : 180-360

* Pulse Test : Pulse Width=0.3ms, Duty Cycle=1%

TYPICAL CHARACTERISTICS
 ($T_A=25^\circ\text{C}$ unless otherwise noted)

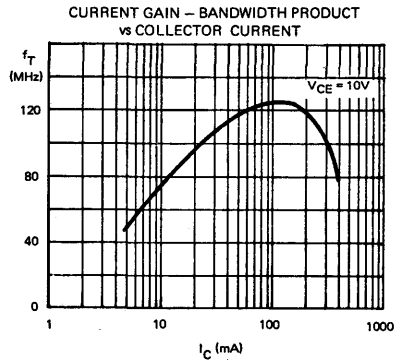
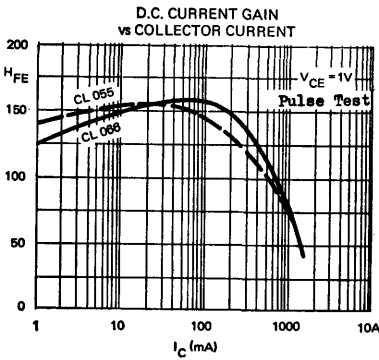
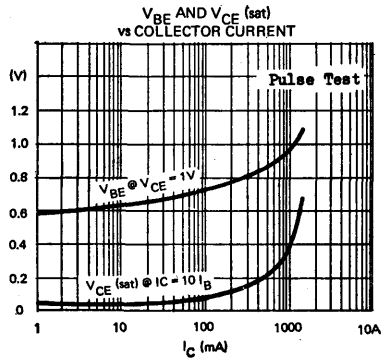
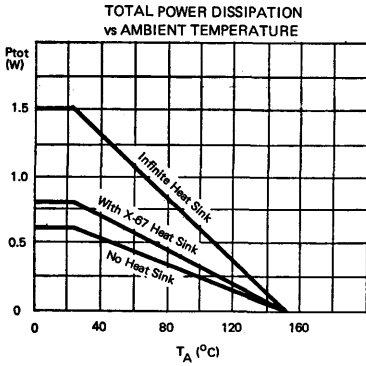

CL138

NPN SILICON PHOTO DARLINGTON TRANSISTOR

THE CL138 IS AN NPN SILICON PHOTO DARLINGTON TRANSISTOR FOR USE IN PHOTO DETECTOR CIRCUITS IN WHICH VERY SENSITIVE LIGHT CURRENT IS REQUIRED. THE DEVICE IS SUPPLIED IN SELECTED LIGHT CURRENT GROUPS.

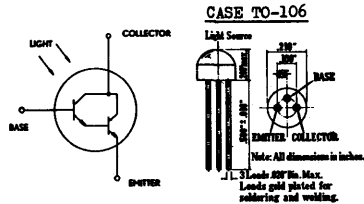

Note : The base terminal may be isolated from the internal silicon chip upon request.

ABSOLUTE MAXIMUM RATINGS

Collector-Emitter Voltage	V _{CEO}	18V
Emitter-Collector Voltage	V _{ECO}	5V
Collector Current	I _C	100mA
Total Power Dissipation @ T _A ≤ 25°C	P _{tot}	300mW
Operating Junction & Storage Temperature	T _j , T _{stg}	-55 to 100°C

ELECTRICAL CHARACTERISTICS (T_A=25°C unless otherwise noted)

PARAMETER	SYMBOL	MIN	TYP	MAX	UNIT	TEST CONDITIONS	
Collector-Emitter Breakdown Voltage	V _{CEO} *	18	35		V	I _C =10mA (Pulsed) I _B =0	
Emitter-Collector Breakdown Voltage	V _{ECO} *	5	8.5		V	I _E =0.1mA I _B =0	
Collector Cutoff Current (=Dark Current)	I _{CEO} *			1	μA	V _{CE} =5V I _B =0	
Light Current	I _L **	15		80	mA	V _{CE} =3V H=2mW/cm ²	
		Group A	15	25	40	mA	V _{CE} =3V H=2mW/cm ²
		Group B	30	50	80	mA	V _{CE} =3V H=2mW/cm ²

* Tested in complete darkness.

** The light current is the collector to emitter current measured at specified irradiance (H). The radiation source is an unfiltered tungsten filament lamp at 2874°K color temperature.

TYPICAL CHARACTERISTICS AT $T_A=25^\circ\text{C}$

SWITCHING TIME

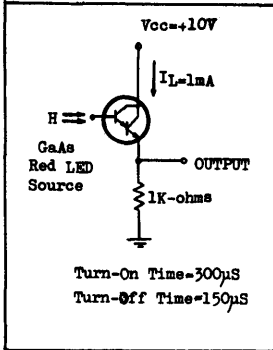

LIGHT CURRENT vs COLLECTOR-EMITTER VOLTAGE

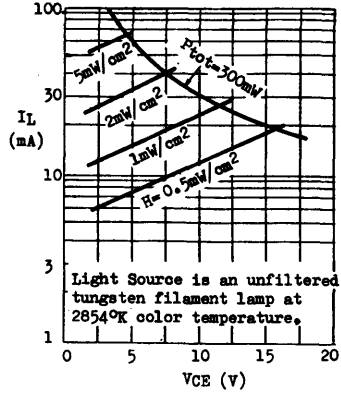

SPECTRAL RESPONSE

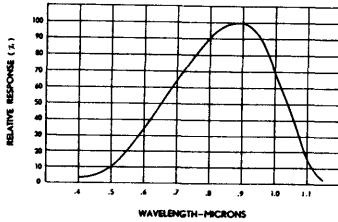

RELATIVE RESPONSE VS. INCIDENT ANGLE

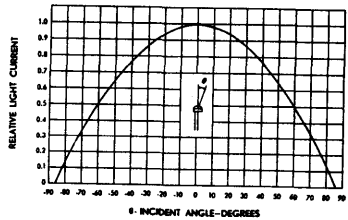

CL155 CL166

COMPLEMENTARY SILICON PLANAR LOW VCEK TRANSISTORS

THE CL155 (PNP) AND CL166 (NPN) ARE SILICON PLANAR EPITAXIAL COMPLEMENTARY PAIR SPECIALLY DESIGNED FOR 2-WATT AUDIO AMPLIFIER OUTPUT AND SWITCHING APPLICATIONS. THEY FEATURE LOW COLLECTOR-EMITTER KNEE VOLTAGE AND GOOD LINEARITY OF D.C. CURRENT GAIN.

TO-92A



EBC

X-67 HEAT SINK

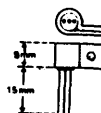

ABSOLUTE MAXIMUM RATINGS

For pin 1 device, voltage and current values are negative

Collector-Base Voltage	V_{CB0}	30V
Collector-Emitter Voltage	V_{CE0}	25V
Emitter-Base Voltage	V_{EB0}	5V
Collector Current	I_C	1.5A
Collector Peak Current ($t \leq 50\text{ms}$)	I_{CM}	2.2A
Total Power Dissipation @ $T_A \leq 25^\circ\text{C}$	P_{tot}	1.5W
With X-67 Heat Sink @ $T_A \leq 25^\circ\text{C}$		800mW
Without Heat Sink @ $T_A \leq 25^\circ\text{C}$		625mW
Operating Junction & Storage Temperature	T_j, T_{stg}	-55 to 150°C

ELECTRICAL CHARACTERISTICS ($T_A = 25^\circ\text{C}$ unless otherwise noted)

PARAMETER	SYMBOL	MIN	TYP	MAX	UNIT	TEST CONDITIONS
Collector-Base Breakdown Voltage	BV_{CB0}	30			V	$I_C = 100\mu\text{A}$ $I_B = 0$
Collector-Emitter Breakdown Voltage	LV_{CE0}^*	25			V	$I_C = 10\text{mA}$ $I_B = 0$
Collector Cutoff Current	I_{CES}			0.5	μA	$V_{CE} = 20\text{V}$ $V_{BE} = 0$
Emitter Cutoff Current	I_{EB0}			1.0	μA	$V_{EB} = 5\text{V}$ $I_C = 0$
Collector-Emitter Knee Voltage	V_{CEK}		0.2	0.4	V	$I_C = 0.2\text{A}$ $I_B = \text{value at which } I_C = 0.22\text{A}$ $V_{CE} = 1\text{V}$
Collector-Emitter Saturation Voltage	$V_{CE(sat)}^*$		0.25	0.45	V	$I_C = 1\text{A}$ $I_B = 0.1\text{A}$
Base-Emitter Voltage	V_{BE}^*		0.82	1.2	V	$I_C = 0.5\text{A}$ $V_{CE} = 1\text{V}$
D.C. Current Gain (Note)	$H_{FE} 1^*$	50	160	360		$I_C = 0.1\text{A}$ $V_{CE} = 1\text{V}$
	$H_{FE} 2^*$	30	110			$I_C = 1\text{A}$ $V_{CE} = 2\text{V}$
Current Gain-Bandwidth Product	f_T		120		MHz	$I_C = 50\text{mA}$ $V_{CE} = 10\text{V}$

Note : $H_{FE} 1$ is classified as follows.

Group A : 50-100

Group B : 80-160

Group C : 120-240

Group D : 180-360

* Pulse Test : Pulse Width=0.3ms, Duty Cycle=1%

TYPICAL CHARACTERISTICS

($T_A = 25^\circ\text{C}$ UNLESS OTHERWISE NOTED)

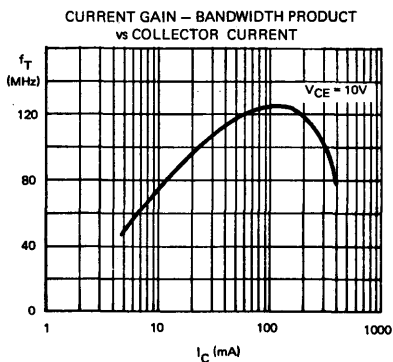
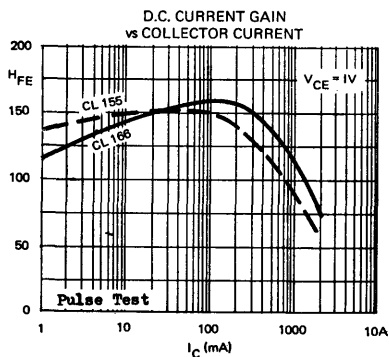
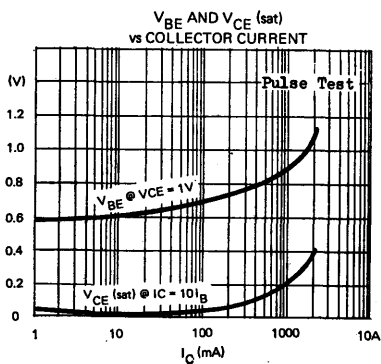
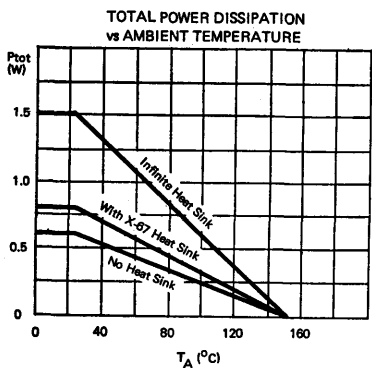

APPLICATION NOTE (MEAP 168)

LOW VOLTAGE OTL AUDIO AMPLIFIER (RL=4~8Ω)

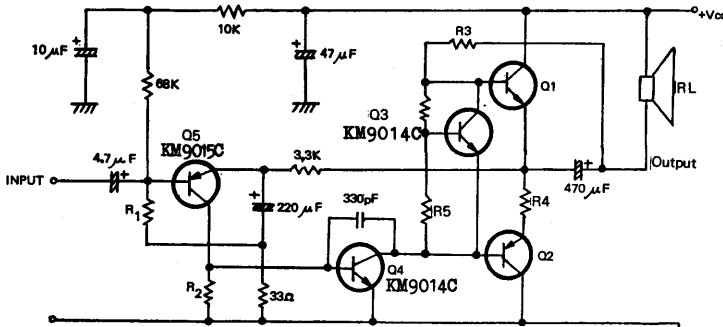

All resistances are in ohms. Quiescent current is very stable when Q3 is placed close to Q2.

CIRCUIT DETAILS	SUPPLY VOLTAGE (RL=8 ohms)					SUPPLY VOLTAGE (RL=4ohms)			
	12V	9V	7.5V	6V	4.5V	9V	7.5V	6V	4.5V
R1	56K	47K	39K	33K	27K	56K	39K	33K	27K
R2	2.2K	2.2K	2.2K	2.4K	3K	2.7K	2.4K	2.4K	3K
R3	390	390	330	220	120	270	270	220	120
R4	1	1	0	0	0	1	0	0	0
R5	560	470	470	470	470	510	510	470	470
Q1,HFE group C or D	CL166	CL066	CL066	CL066	CL066	CL166	CL166	CL066	CL066
Q2,HFE group C or D	CL155	CL055	CL055	CL055	CL055	CL155	CL155	CL055	CL055
10% THD Output	* 2W	1.1W	0.75W	0.5W	0.23W	*1.9W	*1.5W	0.9W	0.4W
Input Impedance	55K	55K	53K	50K	47K	53K	50K	47K	45K
Input Sensitivity	43mV	34mV	27mV	23mV	16mV	35mV	28mV	24mV	16mV
THD @ 0.5W Output	0.5%	0.6%	1%	10%	—	0.5%	0.7%	1%	—
Frequency Response	42Hz to 38KHz, -3dB					70Hz to 38KHz, -3dB			
Current Drain									
@ no signal	14mA	13mA	13mA	13mA	13mA	16mA	15mA	14mA	14mA
@ 10% THD output	230mA	170mA	140mA	120mA	72mA	290mA	255mA	210mA	145mA

* Output transistors mounted to X-67 heat sink.

USING X-67 HEAT SINK TO ITS FULL ADVANTAGES

The X-67 heat sink is specially designed for the low V_{CEK} transistors to perform two functions.

1. Permits 2-Watts continuous output power in the amplifier circuit shown in last page.
2. Provides excellent stability of quiescent current when the biasing transistor (Q3) shares common heat sink with the PNP output transistor (Q2). The arrangement is shown in the following diagram.

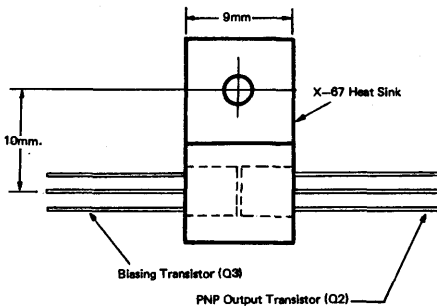

CL855 CL866

COMPLEMENTARY SILICON AF MEDIUM POWER TRANSISTORS

THE CL855 (PNP) AND CL866 (NPN) ARE SILICON PLANAR EPITAXIAL TRANSISTORS OF COMPLEMENTARY CHARACTERISTICS. THEY ARE DESIGNED FOR USE IN AF LARGE SIGNAL AMPLIFIERS AND MEDIUM SPEED SWITCHING UP TO 1.5A PEAK CURRENT.

CASE TO-92A X-67 HEAT SINK

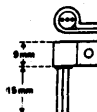

ABSOLUTE MAXIMUM RATINGS

For p-n-p device, voltage and current values are negative

Collector-Base Voltage	V _{CB0}	70V
Collector-Emitter Voltage	V _{CE0}	60V
Emitter-Base Voltage	V _{EB0}	5V
Collector Current	I _C	1A
Collector Peak Current (t ≤ 50μs)	I _{CM}	1.5A
Total Power Dissipation @ T _C ≤ 25°C	P _{tot}	1.5W
With X-67 Heat Sink @ T _A ≤ 25°C		800mW
No Heat Sink @ T _A ≤ 25°C		625mW
Operating Junction & Storage Temperature	T _j , T _{stg}	-55 to 150°C

ELECTRICAL CHARACTERISTICS (T_A=25°C unless otherwise noted)

PARAMETER	SYMBOL	MIN	TYP	MAX	UNIT	TEST CONDITIONS
Collector-Base Breakdown Voltage	V _{CB0}	70			V	I _C =100μA I _B =0
Collector-Emitter Breakdown Voltage	V _{CE0} *	60			V	I _C =10mA I _B =0
Collector Cutoff Current	I _{CES}			0.5	μA	V _{CE} =50V V _{BE} =0
Emitter Cutoff Current	I _{EB0}			1	μA	V _{EB} =5V I _C =0
Collector-Emitter Knee Voltage	V _{CEK}		0.45		V	I _C =0.2A, I _B =value at which I _C =0.22A V _{CE} =1V
Collector-Emitter Saturation Voltage	V _{CE(sat)} *		0.23	0.5	V	I _C =0.5A I _B =0.05A
Base-Emitter Voltage	V _{BE} *		0.85	1.2	V	I _C =0.5A V _{CE} =2V
D.C. Current Gain (Note)	h _{FE} 1*	50	120	240		I _C =0.1A V _{CE} =2V
	h _{FE} 2*	20	55			I _C =1A V _{CE} =4V
Current Gain-Bandwidth Product	f _T	50	150		MHz	I _C =50mA V _{CE} =10V
Collector-Base Capacitance	C _{ob}		15	25	pF	V _{CB} =10V I _B =0 f=1MHz

* Pulse Test : Pulse Width=0.3μs, Duty Cycle=1%

Note : h_{FE} 1 is classified as follows. Group A : 50-100 Group B : 80-160 Group C : 120-240

TYPICAL CHARACTERISTICS ($T_A = 25^\circ\text{C}$ UNLESS OTHERWISE SPECIFIED)

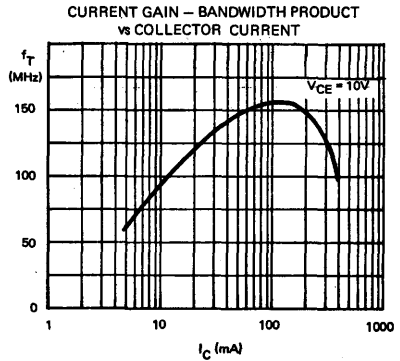
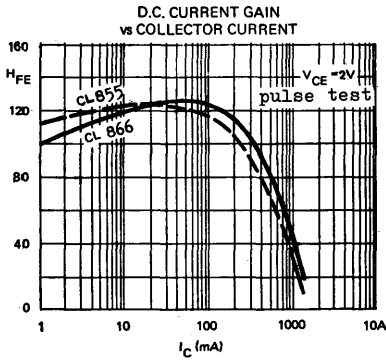
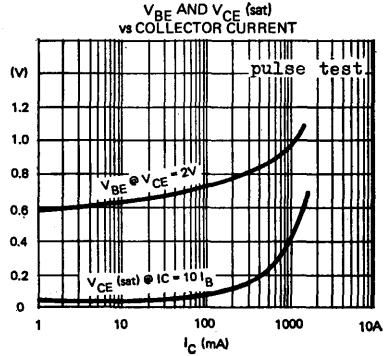
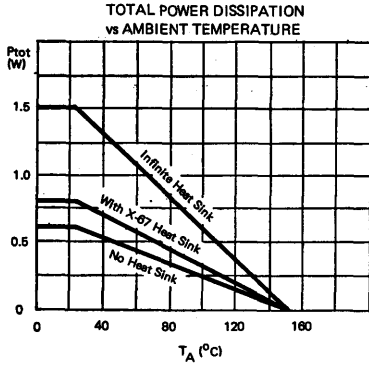

CX PRODUCT LINE

DISCRETE SILICON TRANSISTORS FOR PORTABLE B & W TV RECEIVERS

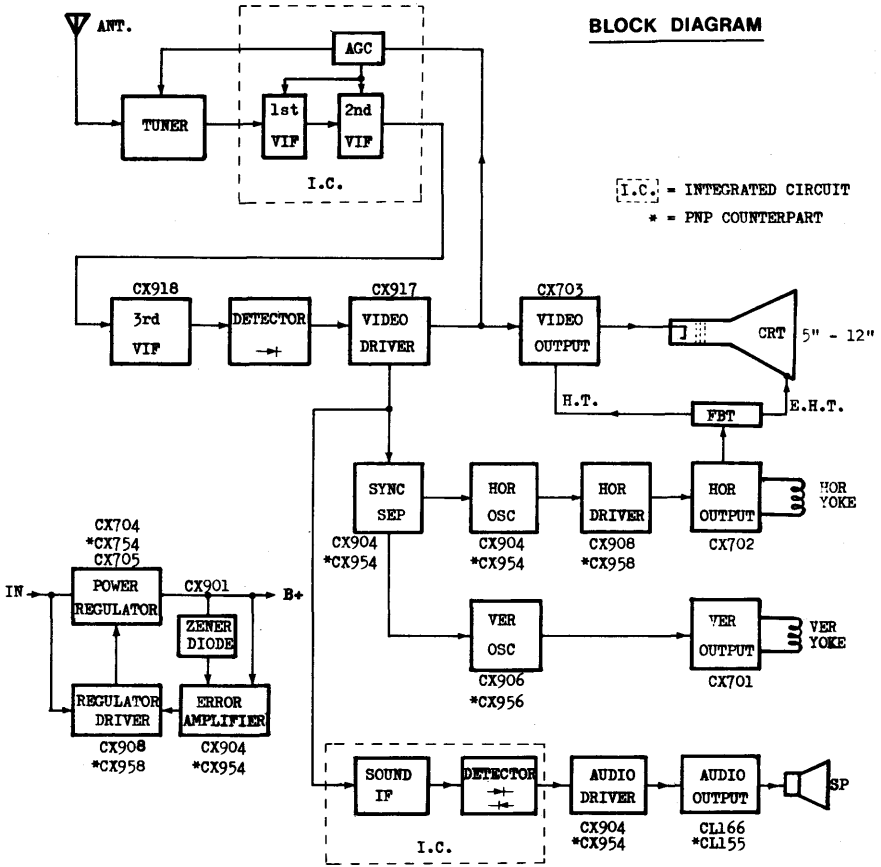

CX PRODUCT LINE

CX PRODUCT LINE --- DEVICE SPECIFICATIONS (T_A=25°C unless otherwise noted)

APPLICATIONS	TYPE		CASE		MAX RATINGS			ELECTRICAL CHARACTERISTICS				
	NPN	PNP	IC (mA)	V _{CEO} (V)	P _{tot} (mW)	I _{CEO} (μA)	V _{CE(sat)} (V)	IC / IB (mA)/(mA)	h _{FE} (mA)/(V)	f _T ● I _C /V _{CE} (MHz)(mA)/(V)	C _{ob} ● V _{CB} (pF) (V)	
VER. OUTPUT	CX701	-	2A	120		10 ● 100	1	● 1A/0.1A	30-120 ● 0.5A/5	-	-	
	CX701A	-	2A	150	(25W)	10 ● 100	1	● 1A/0.1A	30-120 ● 0.5A/5	-	-	
HOR. OUTPUT	CX702	-	5A	160		100 ● 100	2	● 4A/0.8A	15-70 ● 4A/5	-	-	
	CX702A	-	5A	(160)	(40W)	100 ● 100	2	● 4A/0.8A	15-70 ● 4A/5	-	-	
VIDEO OUTPUT	CX705	-	100	160		0.1 ● 120	1.5	● 20/2	40-200 ● 10/10	50	● 10/20	
	CX703A	-	100	200	625	0.1 ● 150	1.5	● 20/2	40-200 ● 10/10	50	● 10/20	
	CX703B	-	100	250	250	0.1 ● 150	1.5	● 20/2	40-200 ● 10/10	50	● 10/20	
POWER REGULATOR	CX704	-	4A	50	(30W)	1 ● 30	1	● 2A/0.2A	40-240 ● 1A/2	3	● 0.2A/5	
	CX705	-	7A	45	(75W)	200 ● 30	1.2	● 3A/0.3A	20-70 ● 3A/4	0.5	● 0.5A/10	
CX705A	-	7A	60	45	(75W)	200 ● 30	1.2	● 3A/0.3A	20-70 ● 3A/4	0.5	● 0.5A/10	
GENERAL PURPOSE	CX901	-	100	40	300	0.1 ● 30	0.4	● 50/5	40-150 ● 1/5	80	● 1/5	
	CX901	-	100	40	300	0.1 ● 30	0.4	● 50/5	40-150 ● 1/5	80	● 1/5	
HOR. OSC SYNC. SEPARATOR AUDIO DRIVER ERROR AMPLIFIER	CX904	-	100	40	300	0.1 ● 30	0.4	● 50/5	80-540 ● 5/5	80	● 10/10	
	CX904	-	100	40	300	0.1 ● 30	0.4	● 50/5	80-540 ● 5/5	80	● 10/10	
VER. OSC	CX906	-	500	40	500	0.1 ● 30	0.5	● 250/25	50-360 ● 50/1	80	● 50/10	
	CX906	-	500	40	500	0.1 ● 30	0.5	● 250/25	50-360 ● 50/1	80	● 50/10	
HOR. DRIVER REGULATOR DRIVER	CX908	-	1A	40	625	0.1 ● 30	0.5	● 500/50	80-360 ● 100/1	60	● 50/10	
	CX908	-	1A	40	625	0.1 ● 30	0.5	● 500/50	80-360 ● 100/1	60	● 50/10	
VIDEO DRIVER	CX917	-	50	30	250	0.1 ● 20	0.4	● 20/2	40-150 ● 5/10	200	● 5/10	
	CX917	-	50	30	250	0.1 ● 20	0.4	● 20/2	40-150 ● 5/10	200	● 5/10	
3rd VIDEO IF	CX918	-	50	20	250	0.1 ● 20	0.4	● 20/2	40-150 ● 7/10	400	● 7/10	
CX918	-	50	20	250	0.1 ● 20	0.4	● 20/2	40-150 ● 7/10	400	● 7/10		
AUDIO OUTPUT	See CL155 - CL166 data sheet.											



*C_{Te}

CX701 CX701A

NPN SILICON TRANSISTORS

FOR TV VERTICAL OUTPUT APPLICATIONS

THE CX701 AND CX701A ARE NPN SILICON POWER TRANSISTORS RECOMMENDED FOR THE VERTICAL OUTPUT STAGES OF 5" - 12" B & W TELEVISION RECEIVERS.

CASE TO-220B



ABSOLUTE MAXIMUM RATINGS

		<u>CX701</u>	<u>CX701A</u>
Collector-Base Voltage	V _{CB0}	150V	180V
Collector-Emitter Voltage	V _{CE0}	120V	150V
Emitter-Base Voltage	V _{EB0}		5V
Collector Current	I _C		2A
Collector Peak Current (t ≤ 10μS)	I _{CM}		4A
Total Power Dissipation (T _C ≤ 25°C)	P _{tot}		25W
(T _A ≤ 25°C)			1.5W
Operating Junction & Storage Temperature	T _j , T _{stg}		-55 to 150°C

ELECTRICAL CHARACTERISTICS (T_A=25°C unless otherwise noted)

PARAMETER	SYMBOL	CX701		UNIT	TEST CONDITIONS
		MIN	MAX		
Collector-Emitter Breakdown Voltage	V _{CE0} *	120	150	V	I _C =100mA I _B =0
Collector Cutoff Current	I _{CB0}	10	10	μA	V _{CB} =100V I _B =0
Emitter Cutoff Current	I _{EB0}	10	10	μA	V _{EB} =5V I _C =0
Collector-Emitter Saturation Voltage	V _{CE(sat)} *	1	1	V	I _C =1A I _B =0.1A
Base-Emitter Voltage	V _{BE} *	0.6 0.85	0.6 0.85	V	I _C =0.2A V _{CE} =5V
D.C. Current Gain	h _{FE} *	30 120	30 120		I _C =0.5A V _{CE} =5V

* Pulse Test : Pulse Width=0.3μS, Duty Cycle=1%

CX701 CX701A

TYPICAL CHARACTERISTICS

($T_A=25^\circ\text{C}$ unless otherwise noted)

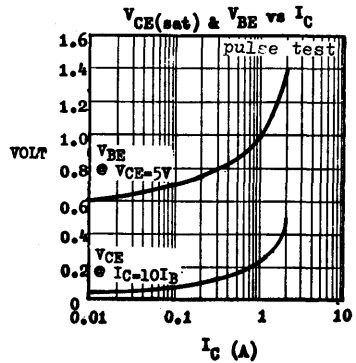
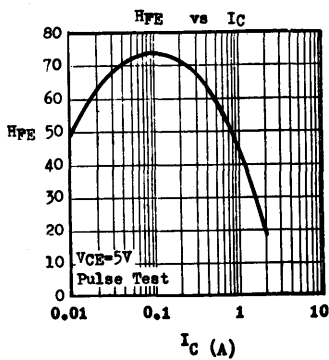
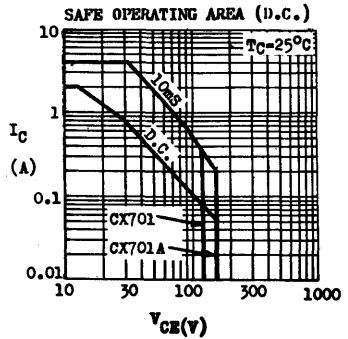
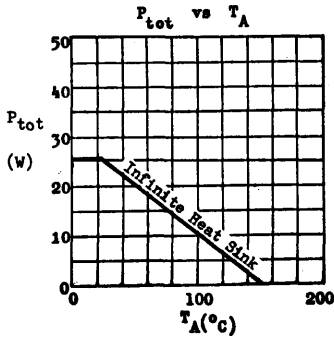

CX702 CX702A

NPN SILICON TRANSISTORS

FOR TV HORIZONTAL OUTPUT APPLICATIONS

THE CX702, CX702A ARE NPN SILICON POWER TRANSISTORS RECOMMENDED FOR THE HORIZONTAL OUTPUT STAGES OF 5" - 12" B & W TELEVISION RECEIVERS.

CASE TO-220B



ABSOLUTE MAXIMUM RATINGS

		CX702	CX702A
Collector-Base Voltage	V_{CB0}	160V	200V
Collector-Emitter Voltage ($V_{BE}=0$)	V_{CES}	160V	200V
Collector-Emitter Voltage ($I_B=0$)	V_{CE0}	80V	100V
Emitter-Base Voltage	V_{EBO}	8V	
Collector Current	I_C	5A	
Collector Peak Current ($t \leq 10\mu s$)	I_{CM}	8A	
Total Power Dissipation ($T_C \leq 25^\circ C$)	P_{tot}	40W	
Operating Junction & Storage Temperature	T_j, T_{stg}	-55 to $150^\circ C$	

ELECTRICAL CHARACTERISTICS ($T_A=25^\circ C$ unless otherwise noted)

PARAMETER	SYMBOL	CX702 MIN MAX	CX702A MIN MAX	UNIT	TEST CONDITIONS
Collector-Emitter Breakdown Voltage	V_{CES}^*	160	200	V	$I_C=100mA$ $V_{BE}=0$
Collector-Emitter Breakdown Voltage	V_{CE0}^*	80	100	V	$I_C=100mA$ $I_B=0$
Collector Cutoff Current	I_{CES}	100	100	μA	$V_{CE}=100V$ $V_{BE}=0$
Emitter Cutoff Current	I_{EBO}	10	10	μA	$V_{EB}=8V$ $I_C=0$
Collector-Emitter Saturation Voltage	$V_{CE(sat)}^*$	2	2	V	$I_C=4A$ $I_B=0.8A$
Base-Emitter Voltage	V_{BE}^*	2	2	V	$I_C=4A$ $V_{CE}=5V$
D.C. Current Gain	H_{FE}^*	15 70	15 70		$I_C=4A$ $V_{CE}=5V$
Fall Time	t_f	1	1	μs	$I_C=4A$ $I_{B1}=0.8A$ $-V_{EB}=5V$ $R_B=5\Omega$

* Pulse Test : Pulse Width=0.3ms, Duty Cycle=1%

CX702 CX702A

TYPICAL CHARACTERISTICS

($T_A=25^\circ\text{C}$ unless otherwise noted)

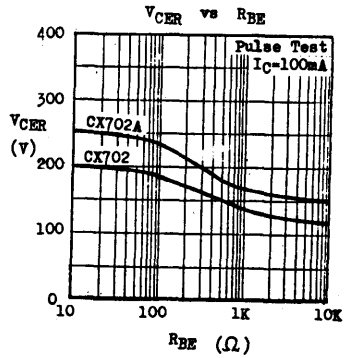
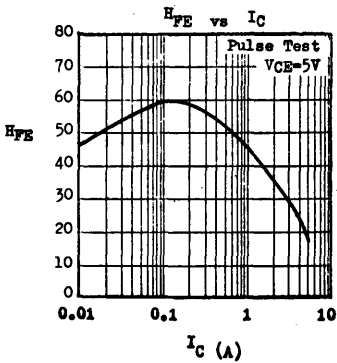
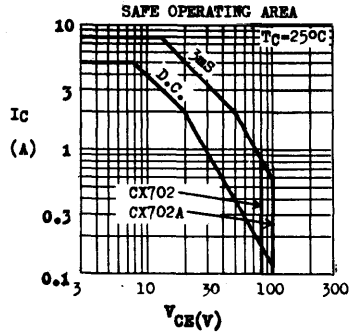
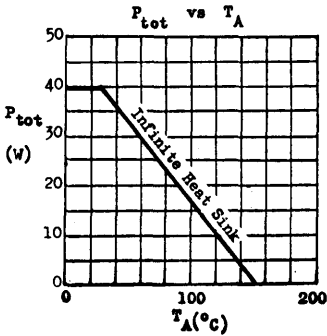

CX703 CX703A CX703B

NPN SILICON VIDEO AMPLIFIERS & HIGH VOLTAGE SWITCHES

THE CX703, CX703A, CX703B ARE NPN SILICON PLANAR TRANSISTORS RECOMMENDED FOR TV VIDEO OUTPUT STAGES AND HIGH VOLTAGE SWITCHES UP TO 100mA COLLECTOR CURRENT. THEY ARE SUPPLIED IN TO-92A PLASTIC CASE WITH OPTIONAL X-67 HEAT SINK.

TO-92A



EBC

X-67 HEAT SINK

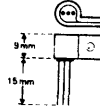

ABSOLUTE MAXIMUM RATINGS

		CX703	CX703A	CX703B
Collector-Base Voltage	V_{CBO}	160V	200V	250V
Collector-Emitter Voltage	V_{CEO}	160V	200V	250V
Emitter-Base Voltage	V_{EBO}		6V	
Collector Current	I_C		100mA	
Total Power Dissipation @ $T_C \leq 25^\circ C$	P_{tot}		1.5W	
With X-67 Heat Sink, $T_A \leq 25^\circ C$			800mW	
No Heat Sink, $T_A \leq 25^\circ C$			625mW	
Operating Junction & Storage Temperature	T_j, T_{stg}		-55 to 150°C	

ELECTRICAL CHARACTERISTICS ($T_A=25^\circ C$ unless otherwise noted)

PARAMETER	SYMBOL	CX703		CX703A		CX703B		UNIT	TEST CONDITIONS
		MIN	MAX	MIN	MAX	MIN	MAX		
Collector-Base Breakdown Voltage	BV_{CBO}	160	200	250				V	$I_C=0.1mA$ $I_E=0$
Collector-Emitter Breakdown Voltage	BV_{CEO}	160	200	250				V	$I_C=1mA$ $I_B=0$
Emitter-Base Breakdown Voltage	BV_{EBO}	6	6	6				V	$I_E=0.1mA$ $I_C=0$
Collector Cutoff Current	I_{CBO}	0.1		0.1	0.1			μA	$V_{CB}=120V$ $I_E=0$ $V_{CB}=150V$ $I_E=0$
Emitter Cutoff Current	I_{EBO}	0.1		0.1	0.1			μA	$V_{EB}=4V$ $I_C=0$
Collector-Emitter Saturation Voltage	$V_{CE(sat)}$	1.5	1.5	1.5				V	$I_C=20mA$ $I_B=2mA$
Base-Emitter Saturation Voltage	$V_{BE(sat)}$	1.2	1.2	1.2				V	$I_C=20mA$ $I_B=2mA$
D.C. Current Gain	h_{FE}	40	200	40	200	40	200		$I_C=10mA$ $V_{CE}=10V$
Current Gain-Bandwidth Product	f_T	50	50	50				MHz	$I_C=10mA$ $V_{CE}=20V$
Feedback Capacitance	C_{re}	3	3	3				pF	$V_{CB}=30V$ $I_E=0$ $f=1MHz$

CX703 CX703A CX703B

TYPICAL CHARACTERISTICS ($T_A=25^\circ\text{C}$ unless otherwise noted)

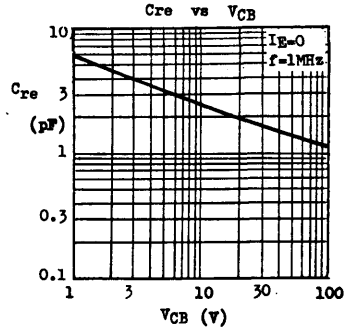
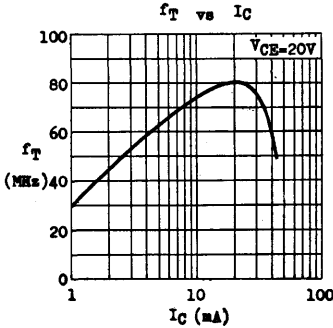
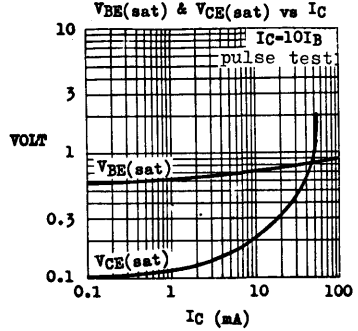
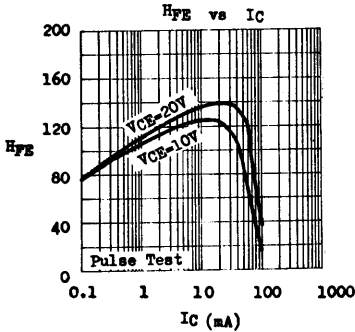
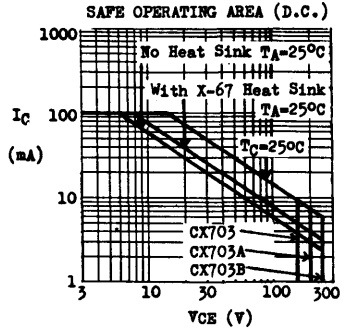
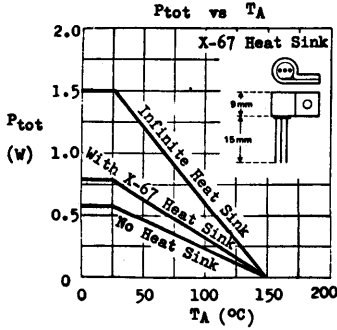

CX704 CX754

COMPLEMENTARY SILICON EPIBASE AF POWER TRANSISTORS

THE CX704 (NPN) AND CX754 (PNP) ARE
COMPLEMENTARY SILICON EPIBASE TRANSISTORS
RECOMMENDED FOR MEDIUM POWER APPLICATIONS
SUCH AS

- * POWER REGULATOR IN PORTABLE TV
- * 10W OTL AUDIO AMPLIFIER
- * MEDIUM SPEED SWITCH UP TO 4A

CASE TO-220B



ABSOLUTE MAXIMUM RATINGS

For a-c stresses, ratings and current values are negative

Collector-Emitter Voltage ($R_{BE}=100\Omega$)	V_{CER}	60V
Collector-Emitter Voltage ($I_B=0$)	V_{CEO}	50V
Emitter-Base Voltage	V_{EBO}	5V
Collector Current	I_C	4A
Collector Peak Current ($t \leq 10\mu s$)	I_{CM}	7A
Total Power Dissipation ($T_C \leq 25^\circ C$)	P_{tot}	30W
Operating Junction & Storage Temperature	T_j, T_{stg}	-55 to $150^\circ C$

THERMAL RESISTANCE

Junction to Case	θ_{jc}	4.17°C/W max.
------------------	---------------	---------------

ELECTRICAL CHARACTERISTICS ($T_A=25^\circ C$ unless otherwise noted)

PARAMETER	SYMBOL	MIN	TYP	MAX	UNIT	TEST CONDITIONS
Collector-Emitter Breakdown Voltage	V_{CER}^*	60			V	$I_C=100mA$ $R_{BE}=100\Omega$
Collector-Emitter Breakdown Voltage	V_{CEO}^*	50			V	$I_C=100mA$ $I_B=0$
Collector Cutoff Current	I_{CER}			1	μA	$V_{CE}=30V$ $R_{BE}=100\Omega$
Emitter Cutoff Current	I_{EBO}			1	μA	$V_{EB}=5V$ $I_C=0$
Collector-Emitter Saturation Voltage	$V_{CE(sat)}^*$	0.35	1		V	$I_C=2A$ $I_B=0.2A$
Base-Emitter Voltage	V_{BE}^*		1	1.5	V	$I_C=2A$ $V_{CE}=2V$
D.C. Current Gain (Note)	$H_{FE} 1^*$	40	160	240		$I_C=1A$ $V_{CE}=2V$
	$H_{FE} 2^*$	30	90			$I_C=10mA$ $V_{CE}=2V$
Current Gain-Bandwidth Product	f_T	3			MHz	$I_C=0.2A$ $V_{CE}=5V$

* Pulse Test : Pulse Width=0.5 μs , Duty Cycle=1%

Note : $H_{FE} 1$ is classified as follows. Group A : 40-80 Group B : 70-140
Group C : 120-240

TYPICAL CHARACTERISTICS

($T_A=25^\circ\text{C}$ unless otherwise noted)

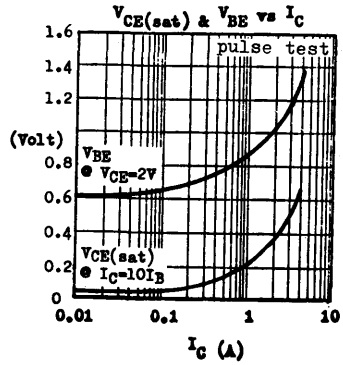
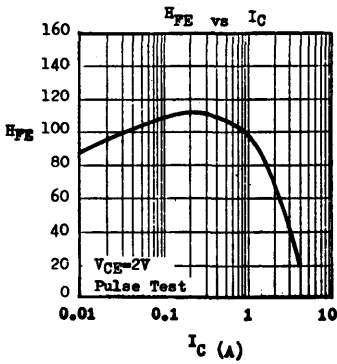
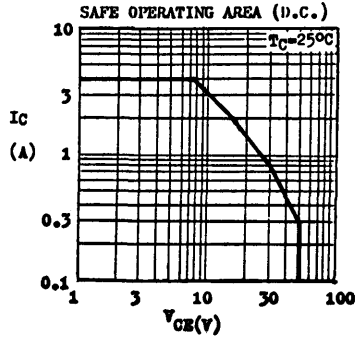
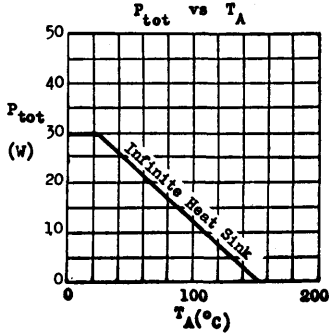

CX705 CX705A

NPN SILICON SINGLE DIFFUSED MESA POWER TRANSISTORS

THE CX705 AND CX705A ARE NPN SILICON SINGLE DIFFUSED MESA POWER TRANSISTORS RECOMMENDED FOR POWER REGULATORS, AUDIO AMPLIFIERS AND LOW SPEED SWITCHES REQUIRING VERY LARGE SAFE OPERATING AREA.

CASE TO-3



ABSOLUTE MAXIMUM RATINGS

		<u>CX705</u>	<u>CX705A</u>
Collector-Emitter Voltage ($R_{BE}=100\Omega$)	V _{CER}	55V	70V
Collector-Emitter Voltage ($I_B=0$)	V _{CEO}	45V	60V
Emitter-Base Voltage	V _{EBO}	7V	
Collector Current	I _C	7A	
Total Power Dissipation ($T_C \leq 25^\circ\text{C}$)	P _{tot}	75W	
Operating Junction & Storage Temperature	T _j , T _{stg}	-55 to 175°C	

THERMAL RESISTANCE

Junction to Case	θ_{jc}	20°C/W max.
------------------	---------------	-------------

ELECTRICAL CHARACTERISTICS ($T_A=25^\circ\text{C}$ unless otherwise noted)

PARAMETER	SYMBOL	CX705		CX705A		UNIT	TEST CONDITIONS
		MIN	MAX	MIN	MAX		
Collector-Emitter Breakdown Voltage	V _{CER} *	55		70		V	I _C =0.2A R _{BE} =100Ω
Collector-Emitter Breakdown Voltage	V _{CEO} *	45		60		V	I _C =0.2A I _B =0
Emitter-Base Breakdown Voltage	V _{EBO}	7		7		V	I _B =5mA I _C =0
Collector Cutoff Current	I _{CBO}		1		1	mA	V _{CE} =30V I _B =0
Collector Cutoff Current	I _{CER}		0.2		0.2	mA	V _{CE} =30V R _{BE} =100Ω
Collector-Emitter Saturation Voltage	V _{CE(sat)} *		1.2		1.2	V	I _C =3A I _B =0.3A
Base-Emitter Voltage	V _{BE} *		1.8		1.8	V	I _C =3A I _B =0.3A
D.C. Current Gain	h _{FE} *	20	70	20	70		I _C =3A V _{CE} =4V
		5		5			I _C =7A V _{CE} =4V
Current Gain-Bandwidth Product	f _T	0.5		0.5		MHz	I _C =0.5A V _{CE} =10V

* Pulse Test : Pulse Width=0.3μS, Duty Cycle=1%

CX705 CX705A

TYPICAL CHARACTERISTICS

($T_A=25^\circ\text{C}$ unless otherwise noted).

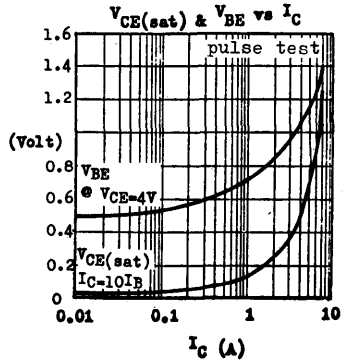
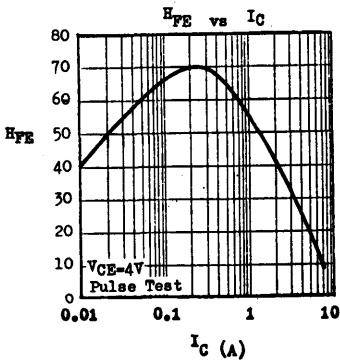
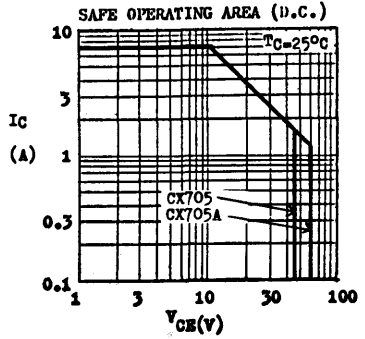
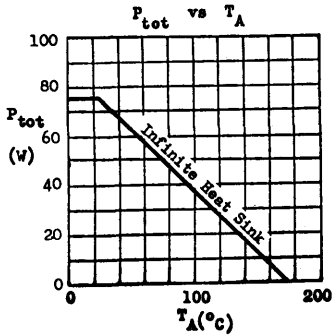

CX901

NPN SILICON GENERAL PURPOSE AMPLIFIER AND ZENER DIODE

THE CX901 IS NPN SILICON PLANAR EPITAXIAL TRANSISTOR FOR GENERAL PURPOSE SMALL SIGNAL APPLICATIONS FROM D.C. TO FREQUENCIES BEYOND 10MHz. ITS EMITTER-BASE JUNCTION CAN ALSO BE USED AS A 7-VOLT ZENER DIODE.

CASE TO-92A



EBC

ABSOLUTE MAXIMUM RATINGS

Collector-Base Voltage	V_{CBO}	45V
Collector-Emitter Voltage	V_{CEO}	40V
Collector Current	I_C	100mA
Total Power Dissipation ($T_A \leq 25^\circ C$)	P_{tot}	300mW
Operating Junction & Storage Temperature	T_j, T_{stg}	-55 to 150°C

ELECTRICAL CHARACTERISTICS ($T_A=25^\circ C$ unless otherwise noted)

PARAMETER	SYMBOL	MIN	TYP	MAX	UNIT	TEST CONDITIONS
Collector-Base Breakdown Voltage	BV_{CBO}	45			V	$I_C=0.1mA, I_E=0$
Collector-Emitter Breakdown Voltage	BV_{CEO}	40			V	$I_C=1mA, I_B=0$
Emitter-Base Breakdown Voltage	BV_{EBO}	6.7	7.2	7.7	V	$I_E=5mA, I_C=0$
			7.4		V	$I_E=25mA, I_C=0^*$
Collector Cutoff Current	I_{CBO}			100	nA	$V_{CE}=50V, I_E=0$
Emitter Cutoff Current	I_{EBO}			100	nA	$V_{EB}=3V, I_C=0$
Collector-Emitter Saturation Voltage	$V_{CE(sat)}$	0.15	0.4		V	$I_C=50mA, I_B=5mA$
Base-Emitter Voltage	V_{BE}	0.62	0.8		V	$I_C=1mA, V_{CE}=5V$
D.C. Current Gain	h_{FE}	40	70	150		$I_C=1mA, V_{CE}=5V$
		30	55			$I_C=0.1mA, V_{CE}=5V$
Current Gain-Bandwidth Product	f_T	80	140		MHz	$I_C=1mA, V_{CE}=5V$
Collector-Base Capacitance	C_{ob}	2.7	3.5		pF	$V_{CB}=10V, I_E=0$
						$f=1MHz$
Collector-Base Time Constant	τ_{cb}	60	150		pS	$I_C=1mA, V_{CE}=5V$
						$f=31.8MHz$

* Maximum operating emitter current is 30mA when the emitter-base junction is used as a zener diode (collector open).

TYPICAL CHARACTERISTICS
 (TA=25°C unless otherwise noted)

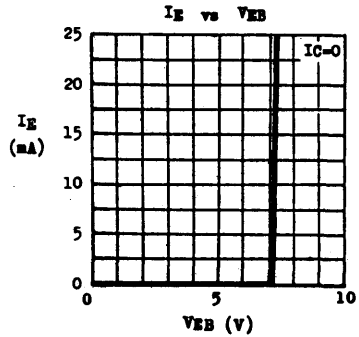
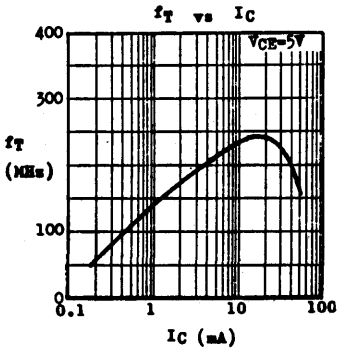
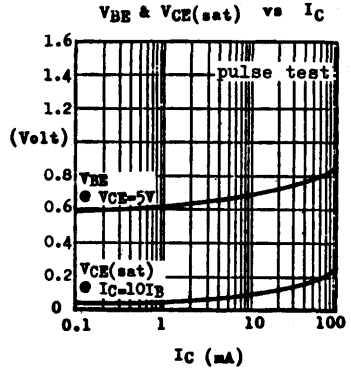
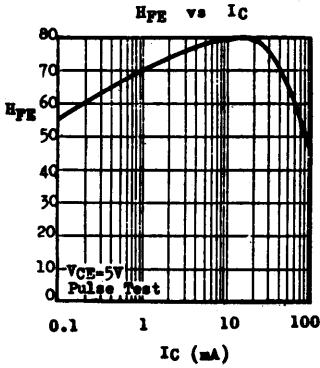

CX904 CX954

COMPLEMENTARY SILICON GENERAL PURPOSE AF AMPLIFIERS

THE CX904 (NPN) AND CX954 (PNP) ARE
COMPLEMENTARY SILICON PLANAR EPITAXIAL
TRANSISTORS RECOMMENDED FOR TV SMALL
SIGNAL PROCESSING CIRCUITS SUCH AS

- * SYNC. SEPARATOR
- * HORIZONTAL OSCILLATOR
- * ERROR AMPLIFIER
- * AUDIO DRIVER

CASE TO-92A



ABSOLUTE MAXIMUM RATINGS		
<small>For p-n-p devices, voltage and current values are negative</small>		
Collector-Base Voltage	V _{CB0}	45V
Collector-Emitter Voltage	V _{CE0}	40V
Emitter-Base Voltage	V _{EB0}	5V
Collector Current	I _C	100mA
Total Power Dissipation (T _A ≤ 25°C)	P _{tot}	300mW
Operating Junction & Storage Temperature	T _j , T _{stg}	-55 to 150°C

ELECTRICAL CHARACTERISTICS (T_A=25°C unless otherwise noted)

PARAMETER	SYMBOL	MIN	TYP	MAX	UNIT	TEST CONDITIONS
Collector-Base Breakdown Voltage	BV _{CB0}	45			V	I _C =0.1mA I _B =0
Collector-Emitter Breakdown Voltage	LV _{CE0}	40			V	I _C =1mA I _B =0
Collector Cutoff Current	I _{CB0}		100		nA	V _{CB} =30V I _B =0
Emitter Cutoff Current	I _{EB0}		100		nA	V _{EB} =4V I _C =0
Collector-Emitter Saturation Voltage	V _{CE(sat)}	0.14	0.4		V	I _C =50mA I _B =5mA
Base-Emitter Voltage	V _{BE}	0.65	0.8		V	I _C =5mA V _{CE} =5V
D.C. Current Gain (Note)	h _{FE} 1	80	260	540		I _C =5mA V _{CE} =5V
	h _{FE} 2	50	200			I _C =0.1mA V _{CE} =5V
Current Gain-Bandwidth Product	f _T	80	200		MHz	I _C =10mA V _{CE} =10V
Collector-Base Capacitance	C _{ob}		3	5	pF	V _{CB} =10V I _B =0 f=1MHz
Noise Figure	NF		2		dB	I _C =0.1mA V _{CE} =5V R _G =10KΩ f=30Hz - 15KHz

Note: h_{FE} 1 is classified as follows.

Group B : 80-160
Group D : 180-360

Group C : 120-240
Group E : 270-540

TYPICAL CHARACTERISTICS

($T_A=25^\circ\text{C}$ unless otherwise noted)

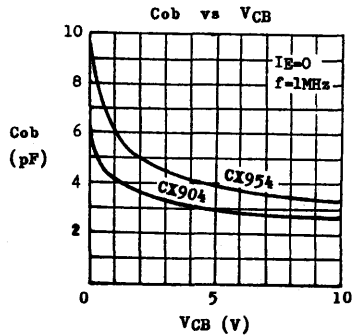
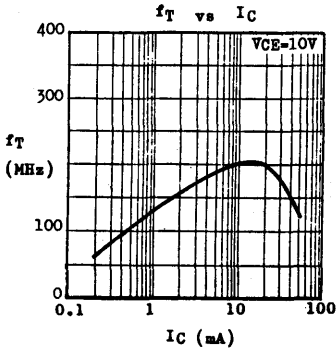
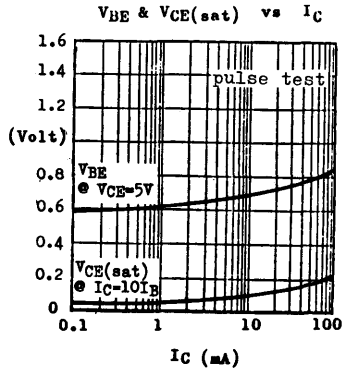
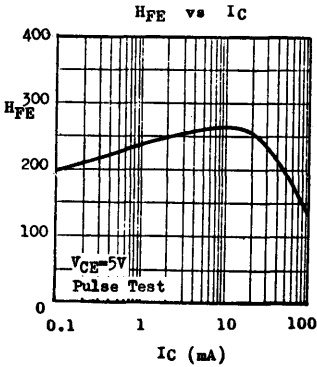

CX906 CX956

COMPLEMENTARY

SILICON AF MEDIUM POWER AMPLIFIERS & DRIVERS

THE CX906 (NPN) AND CX956 (PNP) ARE
 COMPLEMENTARY SILICON PLANAR EPITAXIAL
 TRANSISTORS RECOMMENDED FOR MEDIUM POWER
 APPLICATIONS SUCH AS

- * TV VERTICAL OSCILLATOR
- * POWER REGULATOR DRIVER
- * MEDIUM SPEED SWITCH UP TO 500mA
- * OTL AF AMPLIFIER UP TO 500mW

CASE TO-92A

X-67 Heat Sink

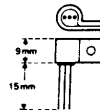

ABSOLUTE MAXIMUM RATINGS

For p-n-p devices, voltage and current values are negative

Collector-Base Voltage	V _{CBO}	45V
Collector-Emitter Voltage	V _{CEO}	40V
Emitter-Base Voltage	V _{EB0}	5V
Collector Current	I _C	500mA
Total Power Dissipation @ T _C ≤ 25°C	P _{tot}	1.2W
With X-67 Heat Sink @ T _A ≤ 25°C		700mW
No Heat Sink @ T _A ≤ 25°C		500mW
Operating Junction & Storage Temperature	T _J , T _{stg}	-55 to 150°C

ELECTRICAL CHARACTERISTICS (T_A=25°C unless otherwise noted)

PARAMETER	SYMBOL	MIN	TYP	MAX	UNIT	TEST CONDITIONS
Collector-Base Breakdown Voltage	V _{CBO}	45			V	I _C =0.1mA I _B =0
Collector-Emitter Breakdown Voltage	V _{CEO} *	40			V	I _C =10mA I _B =0
Collector-Cutoff Current	I _{CBO}			100	nA	V _{CB} =30V I _B =0
Emitter Cutoff Current	I _{EB0}			100	nA	V _{EB} =4V I _C =0
Collector-Emitter Saturation Voltage	V _{CE(sat)} *	0.25	0.5		V	I _C =250mA I _B =25mA
Base-Emitter Saturation Voltage	V _{BE(sat)} *	0.94	1.2		V	I _C =250mA I _B =25mA
D.C. Current Gain (Note)	H _{FE} 1 *	50	160	360		I _C =50mA V _{CE} =1V
	H _{FE} 2 *	30	100			I _C =250mA V _{CE} =2V
Current Gain-Bandwidth Product	f _T	80	200		MHz	I _C =50mA V _{CE} =10V
Collector-Base Capacitance CX906	C _{ob}		4	8	pF	V _{CB} =10V I _B =0
CX956			5	8	pF	f=1MHz

Note : H_{FE} 1 is classified as follows.

Group A : 50-100
 Group C : 120-240

Group B : 80-160
 Group D : 180-360

* Pulse Test : Pulse Width=0.3ms, Duty Cycle=1%

TYPICAL CHARACTERISTICS
 (T_A=25°C unless otherwise noted)

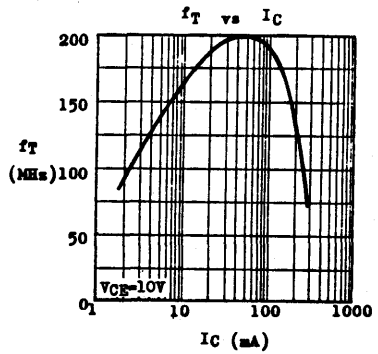
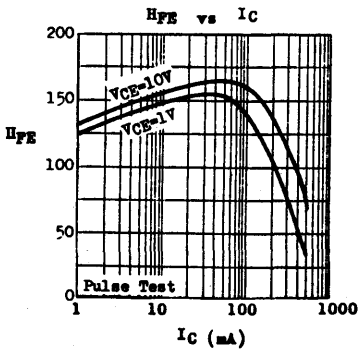
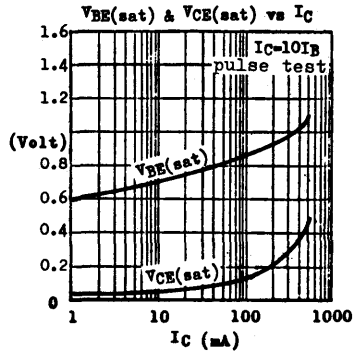
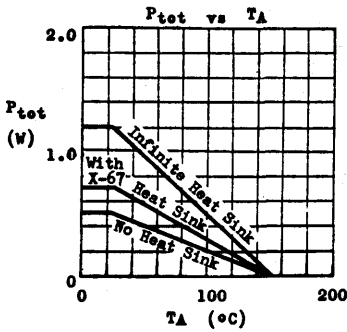

CX908 CX958 COMPLEMENTARY SILICON AF MEDIUM POWER AMPLIFIERS & DRIVERS

THE CX908 (NPN) AND CX958 (PNP) ARE
COMPLEMENTARY SILICON PLANAR EPITAXIAL
TRANSISTORS RECOMMENDED FOR MEDIUM
POWER APPLICATIONS SUCH AS

- * TV HORIZONTAL DRIVER
- * POWER REGULATOR DRIVER
- * MEDIUM SPEED SWITCH UP TO 1A
- * OFL AF AMPLIFIER UP TO 1W

CASE TO-92A

X-67 Heat Sink

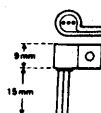

ABSOLUTE MAXIMUM RATINGS

For p-n-p device, voltage and current values are negative

Collector-Base Voltage	V _{CB0}	45V
Collector-Emitter Voltage	V _{CE0}	40V
Emitter-Base Voltage	V _{EB0}	5V
Collector Current	I _C	1A
Total Power Dissipation @ T _C ≤ 25°C	P _{tot}	1.5W
With X-67 Heat Sink @ T _A ≤ 25°C		800mW
No Heat Sink @ T _A ≤ 25°C		625mW
Operating Junction & Storage Temperature	T _j , T _{stg}	-55 to 150°C

ELECTRICAL CHARACTERISTICS (T_A=25°C unless otherwise noted)

PARAMETER	SYMBOL	MIN	TYP	MAX	UNIT	TEST CONDITIONS
Collector-Base Breakdown Voltage	V _{CB0}	45			V	I _C =0.1mA I _B =0
Collector-Emitter Breakdown Voltage	V _{CE0} *	40			V	I _C =10mA I _B =0
Collector Cutoff Current	I _{CB0}			100	nA	V _{CB} =30V I _B =0
Emitter Cutoff Current	I _{EB0}			100	nA	V _{EB} =4V I _C =0
Collector-Emitter Saturation Voltage	V _{CE(sat)} *		0.25	0.5	V	I _C =500mA I _B =50mA
Base-Emitter Saturation Voltage	V _{BE(sat)} *		0.92	1.2	V	I _C =500mA I _B =50mA
D.C. Current Gain (Note)	H _{FE} 1 *	80	170	360		I _C =100mA V _{CE} =1V
	H _{FE} 2 *	40	110			I _C =500mA V _{CE} =2V
Current Gain-Bandwidth Product	f _T	60	150		MHz	I _C =50mA V _{CE} =10V
Collector-Base Capacitance	C _{ob}				pF	V _{CB} =10V I _B =0
	CX908		9	18	pF	f=1MHz
	CX958		14	18	pF	

Note : H_{FE} 1 is classified as follows. Group B : 80-160 Group C : 120-240
Group D : 180-360

* Pulse Test : Pulse Width=0.3ms, Duty Cycle=1%

TYPICAL CHARACTERISTICS
 ($T_A=25^\circ\text{C}$ unless otherwise noted)

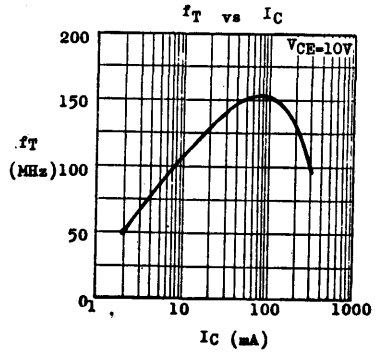
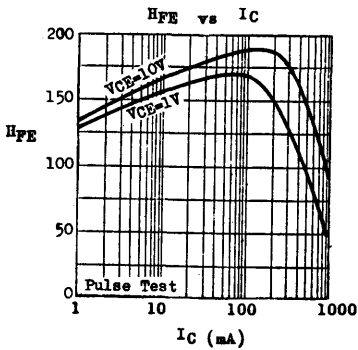
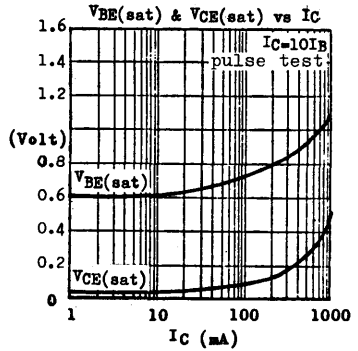
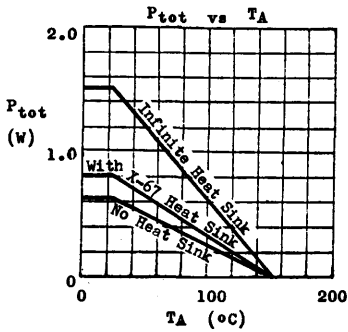

CX917

NPN SILICON HIGH FREQUENCY AMPLIFIER

THE CX917 IS NPN SILICON PLANAR EPITAXIAL TRANSISTOR RECOMMENDED FOR SMALL SIGNAL HIGH FREQUENCY APPLICATIONS SUCH AS

- * TV VIDEO DRIVER
- * FM IF STAGE
- * RF & CONVERTER STAGES UP TO SW BAND

CASE TO-92A



ABSOLUTE MAXIMUM RATINGS

Collector-Base Voltage	V _{CB0}	40V
Collector-Emitter Voltage	V _{CE0}	30V
Emitter-Base Voltage	V _{EB0}	4V
Collector Current	I _c	50mA
Total Power Dissipation (T _A ≤ 25°C)	P _{tot}	250mW
Operating Junction & Storage Temperature	T _j , T _{stg}	-55 to 150°C

ELECTRICAL CHARACTERISTICS (T_A=25°C unless otherwise noted)

PARAMETER	SYMBOL	MIN	TYP	MAX	UNIT	TEST CONDITIONS
Collector-Base Breakdown Voltage	BV _{CB0}	40			V	I _c =0.1mA I _B =0
Collector-Emitter Breakdown Voltage	LV _{CE0}	30			V	I _c =1mA I _B =0
Collector Cutoff Current	I _{cB0}			100	nA	V _{CB} =20V I _B =0
Emitter Cutoff Current	I _{EB0}			100	nA	V _{EB} =3V I _C =0
Collector-Emitter Saturation Voltage	V _{CE(sat)}	0.1	0.4		V	I _c =20mA I _B =2mA
Base-Emitter Voltage	V _{BE}	0.7	0.85		V	I _c =5mA V _{CE} =10V
D.C. Current Gain	h _{FE}	40	80	150		I _c =5mA V _{CE} =10V
		30	60			I _c =0.5mA V _{CE} =10V
Current Gain-Bandwidth Product	f _T	200	330		MHz	I _c =5mA V _{CE} =10V
Feedback Capacitance	C _{re}		0.95	2	pF	V _{CB} =10V I _B =0 f=1MHz
Collector-Base Time Constant	Corbb'		23	45	pS	I _c =1mA V _{CE} =5V f=31.8MHz

TYPICAL CHARACTERISTICS

(TA=25°C unless otherwise noted)

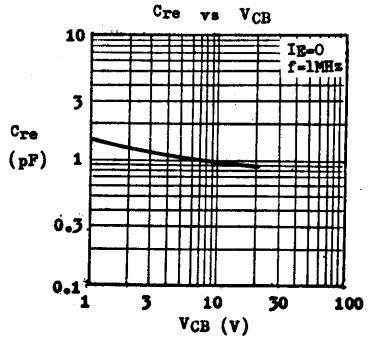
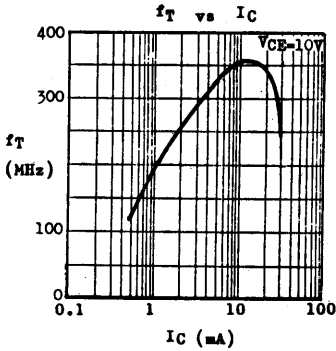
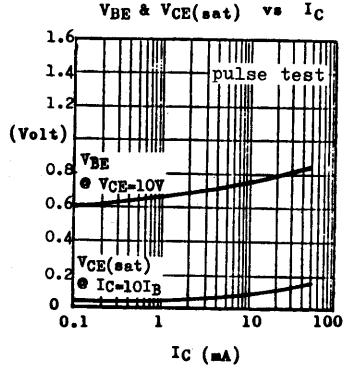
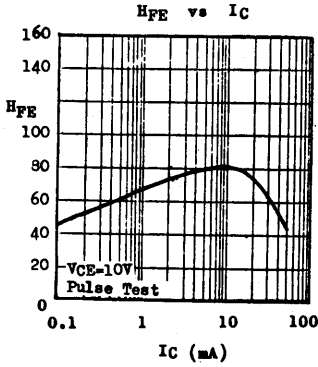

CX918

NPN SILICON VHF AMPLIFIER

THE CX918 IS NPN SILICON PLANAR
EPITAXIAL TRANSISTOR RECOMMENDED
FOR SMALL SIGNAL VHF APPLICATIONS
SUCH AS

- * TV THIRD VIDEO IF STAGE
- * FM RF & CONVERTER STAGES
- * VHF OSCILLATOR

CASE TO-92A



ABSOLUTE MAXIMUM RATINGS

Collector-Base Voltage	V_{CBO}	30V
Collector-Emitter Voltage	V_{CEO}	20V
Emitter-Base Voltage	V_{EBO}	4V
Collector Current	I_C	50mA
Total Power Dissipation ($T_A \leq 25^\circ\text{C}$)	P_{tot}	250mW
Operating Junction & Storage Temperature	T_j, T_{stg}	-55 to 150°C

ELECTRICAL CHARACTERISTICS ($T_A=25^\circ\text{C}$ unless otherwise noted)

PARAMETER	SYMBOL	MIN	TYP	MAX	UNIT	TEST CONDITIONS
Collector-Base Breakdown Voltage	BV_{CBO}	30			V	$I_C=0.1\text{mA}$ $I_E=0$
Collector-Emitter Breakdown Voltage	BV_{CEO}	20			V	$I_C=1\text{mA}$ $I_B=0$
Collector Cutoff Current	I_{CBO}			100	nA	$V_{CB}=20\text{V}$ $I_E=0$
Emitter Cutoff Current	I_{EBO}			100	nA	$V_{EB}=3\text{V}$ $I_C=0$
Collector-Emitter Saturation Voltage	$V_{CE(sat)}$	0.2	0.4		V	$I_C=20\text{mA}$ $I_B=2\text{mA}$
Base-Emitter Voltage	V_{BE}	0.76	0.85		V	$I_C=7\text{mA}$ $V_{CE}=10\text{V}$
D. C. Current Gain	h_{FE}	40	70	150		$I_C=7\text{mA}$ $V_{CE}=10\text{V}$
		30	55			$I_C=0.5\text{mA}$ $V_{CE}=10\text{V}$
Current Gain-Bandwidth Product	f_T	400	620		MHz	$I_C=7\text{mA}$ $V_{CE}=10\text{V}$
Feedback Capacitance	C_{re}	0.8	1.5		pF	$V_{CB}=10\text{V}$ $I_E=0$ $f=1\text{MHz}$
Collector-Base Time Constant	$C_{orbb'}$	20	35		pS	$I_C=1\text{mA}$ $V_{CE}=5\text{V}$ $f=31.8\text{MHz}$
A.C. Power Gain	G_{pe}	28			dB	$I_C=7\text{mA}$ $V_{CE}=10\text{V}$ $f=45\text{MHz}$

TYPICAL CHARACTERISTICS

($T_A=25^\circ\text{C}$ unless otherwise noted)

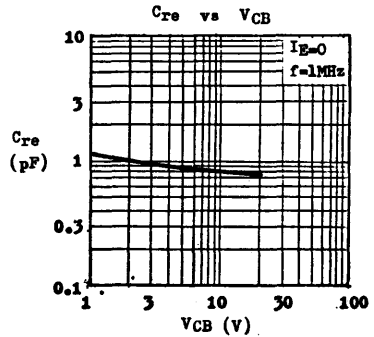
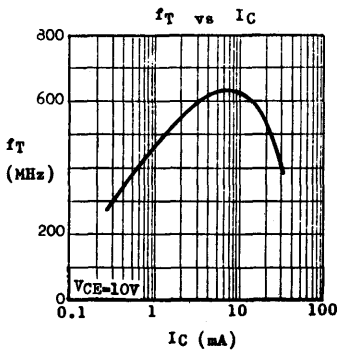
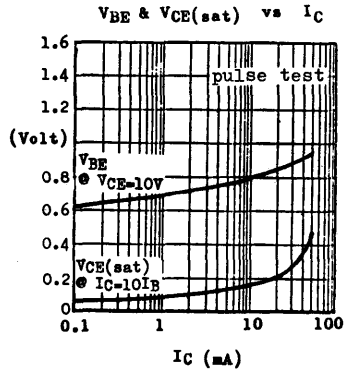
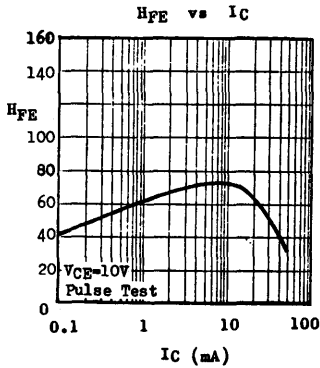

D20 U20

SEMICONDUCTOR KIT FOR BLINKING TOY APPLICATIONS

The D20 · U20 is a two-component semiconductor kit designed for blinking toy applications. It consists of a red LED lamp (D20) and a programmable unijunction transistor (U20). When they are connected with few resistors, a capacitor and a battery, the LED lamp will blink at 2 to 3 cycles per second.

D20 RED L.E.D. LAMP

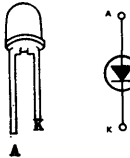

U20 PROGRAMMABLE UNIJUNCTION TRANSISTOR

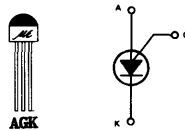

REFERENCE CIRCUIT

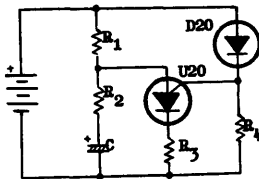

BATTERY (Volts)	R ₁ (ohms)	R ₂ (ohms)	R ₃ (ohms)	R ₄ (ohms)	C (μF/V)
12	6.8K	330	220	100K	22/10
9	6.8K	330	100	100K	22/10
6	6.8K	330	68	100K	33/6
4.5	6.8K	330	0	100K	33/6
3	6.8K	330	0	100K	47/3

Blinking frequency \approx 2 cycles per second. Average current consumption is less than 8mA. R₁ and C can be changed to adjust ON-OFF Time of L.E.D. lamp.

TYPICAL APPLICATION

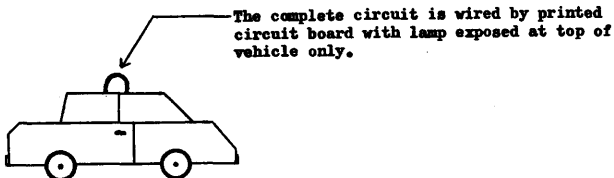

PHYSICAL DIMENSIONS IN INCHES

D20 RED L.E.D. LAMP

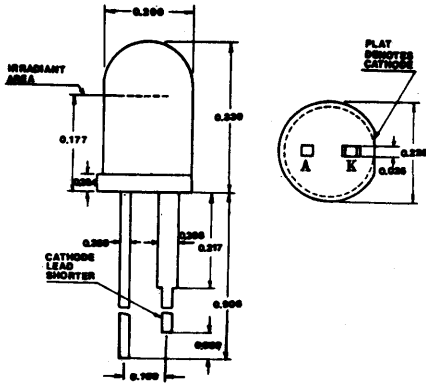

U20 PROGRAMMABLE UNIJUNCTION TRANSISTOR

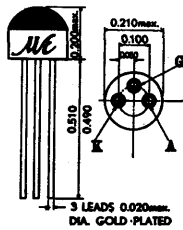

D44C

NPN SILICON EPITAXIAL BASE POWER TRANSISTORS

THE D44C IS A SERIES OF NPN SILICON EPITAXIAL BASE POWER TRANSISTORS DESIGNED FOR MEDIUM SPEED SWITCHING AND AMPLIFIER APPLICATIONS. ITS HIGH CURRENT GAIN-BANDWIDTH PRODUCT ($f_T=30\text{MHz}$ TYP @ $0.2\text{A } I_C$) PERMITS AMPLIFIERS OPERATING AT FREQUENCIES ABOVE 1MHz .

THE D44C IS COMPLEMENTARY TO D45C.

CASE TO-220B



BCE

All dimensions in inches

D44C1	D44C4	D44C7	D44C10
D44C2	D44C5	D44C8	D44C11
<u>D44C3</u>	<u>D44C6</u>	<u>D44C9</u>	<u>D44C12</u>

ABSOLUTE MAXIMUM RATINGS

Collector-Emitter Voltage ($V_{BE}=0$)	V_{CES}	40V	55V	70V	90V
Collector-Emitter Voltage ($I_B=0$)	V_{CEO}	30V	45V	60V	80V
Emitter-Base Voltage	V_{EBO}		5V		
Collector Current	I_C		4A		
Collector Peak Current ($t \leq 10\text{ms}$)	I_{CM}		6A		
Total Power Dissipation @ $T_C \leq 25^\circ\text{C}$ @ $T_A \leq 25^\circ\text{C}$	P_{tot}		30W		
			1.67W		
Junction Temperature	T_j		150°C		
Storage Temperature Range	T_{stg}		-55 to +150°C		

THERMAL RESISTANCE

Junction to Case	θ_{jc}	4.17°C/W	max.
Junction to Ambient	θ_{ja}	75°C/W	max.

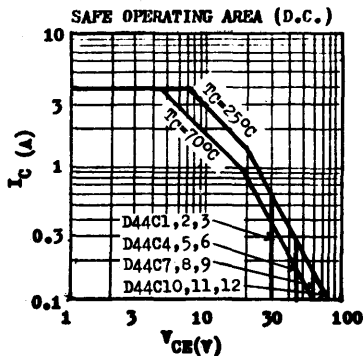
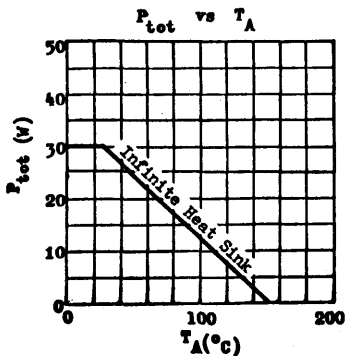

D44C

ELECTRICAL CHARACTERISTICS (TA=25°C unless otherwise noted)

PARAMETER	SYMBOL	MIN	TYP	MAX	UNIT	TEST CONDITIONS
Collector-Emitter Breakdown Voltage	V_{CE0} *					$I_C=100mA$ $I_B=0$
D44C1, 2, 3		30			V	
D44C4, 5, 6		45			V	
D44C7, 8, 9		60			V	
D44C10, 11, 12		80			V	
Collector Cutoff Current	I_{CES}			10	μA	$V_{CE}=\text{Rated } V_{CES}, V_{BE}=0$
Emitter Cutoff Current	I_{EBO}			100	μA	$V_{EB}=5V$ $I_C=0$
Collector-Emitter Saturation Voltage	$V_{CE(sat)}$ *			0.5	V	$I_C=1A$ $I_B=0.05A$
D44C2, 3, 5, 6, 8, 9, 11, 12				0.5	V	$I_C=1A$ $I_B=0.1A$
D44C1, 4, 7, 10						
Base-Emitter Saturation Voltage	$V_{BE(sat)}$ *			1.3	V	$I_C=1A$ $I_B=0.1A$
Base-Emitter Voltage	V_{BE} *		0.82		V	$I_C=1A$ $V_{CE}=1V$
D.C. Current Gain						
D44C2, 3, 5, 6, 8, 9, 11, 12	$H_{FE} 1$ *	40		120		$I_C=0.2A$ $V_{CE}=1V$
D44C1, 4, 7, 10		25				
D44C2, 5, 8, 11	$H_{FE} 2$ *	20				$I_C=1A$ $V_{CE}=1V$
D44C1, 4, 7, 10		10				
D44C3, 6, 9, 12	$H_{FE} 3$ *	20				$I_C=2A$ $V_{CE}=1V$
Current Gain-Bandwidth Product	f_T		30		MHz	$I_C=0.2A$ $V_{CE}=5V$
Collector-Base Capacitance	C_{ob}		40	100	pF	$V_{CB}=10V$ $I_E=0$ $f=1MHz$

* Pulse Test : Pulse Width=0.3mS, Duty Cycle=1%

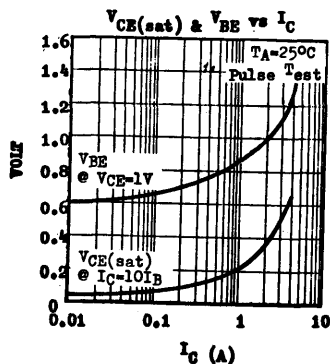
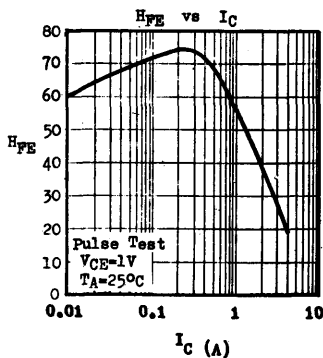

D45C

PNP SILICON EPITAXIAL BASE POWER TRANSISTORS

THE D45C IS A SERIES OF PNP SILICON EPITAXIAL BASE POWER TRANSISTORS DESIGNED FOR MEDIUM SPEED SWITCHING AND AMPLIFIER APPLICATIONS. ITS HIGH CURRENT GAIN-BANDWIDTH PRODUCT ($f_T=30\text{MHz}$ TYP @ $0.2\text{A } I_C$) PERMITS AMPLIFIERS OPERATING AT FREQUENCIES ABOVE 1MHz .
THE D45C IS COMPLEMENTARY TO D44C.

CASE TO-220B



BCE

ABSOLUTE MAXIMUM RATINGS

Collector-Emitter Voltage ($V_{BE}=0$)	$-V_{CES}$	40V	55V	70V	90V
Collector-Emitter Voltage ($I_B=0$)	$-V_{CEO}$	30V	45V	60V	80V
Emitter-Base Voltage	$-V_{EBO}$			5V	
Collector Current	$-I_C$			4A	
Collector Peak Current ($t \leq 10\text{ms}$)	$-I_{CM}$			6A	
Total Power Dissipation @ $T_C \leq 25^\circ\text{C}$ @ $T_A \leq 25^\circ\text{C}$	P_{tot}			30W	1.67W
Junction Temperature	T_j			150°C	
Storage Temperature Range	T_{stg}			-55 to +150°C	

D45C1	D45C4	D45C7	D45C10
D45C2	D45C5	D45C8	D45C11
<u>D45C3</u>	<u>D45C6</u>	<u>D45C9</u>	<u>D45C12</u>

THERMAL RESISTANCE

Junction to Case
Junction to Ambient

θ_{jc}	4.17°C/W	max.
θ_{ja}	75°C/W	max.

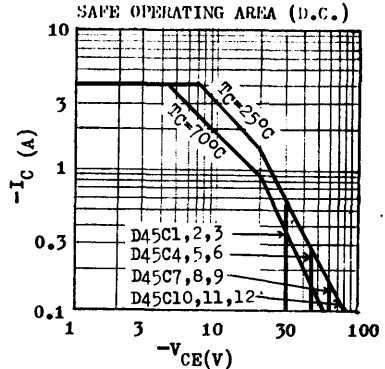
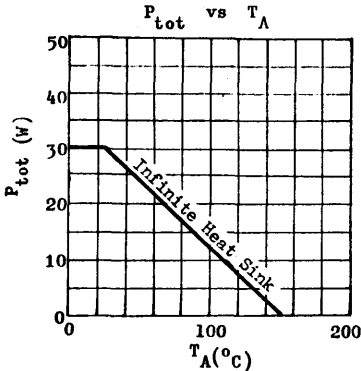

D45C

ELECTRICAL CHARACTERISTICS ($T_A=25^\circ\text{C}$ unless otherwise noted)

PARAMETER	SYMBOL	MIN	TYP	MAX	UNIT	TEST CONDITIONS
Collector-Emitter Breakdown Voltage	$-V_{CE0}$ *					$-I_C=100\text{mA}$ $I_B=0$
D45C1, 2, 3		30			V	
D45C4, 5, 6		45			V	
D45C7, 8, 9		60			V	
D45C10, 11, 12		80			V	
Collector Cutoff Current	$-I_{CES}$			10	μA	$V_{CE}=\text{Rated } V_{CES}$, $V_{BE}=0$
Emitter Cutoff Current	$-I_{EBO}$			100	μA	$-V_{EB}=5\text{V}$ $I_C=0$
Collector-Emitter Saturation Voltage	$-V_{CE(sat)}$ *					
D45C2, 3, 5, 6, 8, 9, 11, 12			0.5		V	$-I_C=1\text{A}$ $-I_B=0.05\text{A}$
D45C1, 4, 7, 10			0.5		V	$-I_C=1\text{A}$ $-I_B=0.1\text{A}$
Base-Emitter Saturation Voltage	$-V_{BE(sat)}$ *			1.3	V	$-I_C=1\text{A}$ $-I_B=0.1\text{A}$
Base-Emitter Voltage	$-V_{BE}$ *		0.85		V	$-I_C=1\text{A}$ $-V_{CE}=1\text{V}$
D.C. Current						
D45C2, 3, 5, 6, 8, 9, 11, 12	$H_{FE} 1$ *	40		120		$-I_C=0.2\text{A}$ $-V_{CE}=1\text{V}$
D45C1, 4, 7, 10		25				
D45C2, 5, 8, 11	$H_{FE} 2$ *	20				$-I_C=1\text{A}$ $-V_{CE}=1\text{V}$
D45C1, 4, 7, 10		10				
D45C3, 6, 9, 12	$H_{FE} 3$ *	20				$-I_C=2\text{A}$ $-V_{CE}=1\text{V}$
Current Gain-Bandwidth Product	f_T		30		MHz	$-I_C=0.2\text{A}$ $-V_{CE}=5\text{V}$
Collector-Base Capacitance	C_{ob}		75	125	pF	$-V_{CB}=10\text{V}$ $I_E=0$ $f=1\text{MHz}$

* Pulse Test : Pulse Width=0.3ms, Duty Cycle=1%

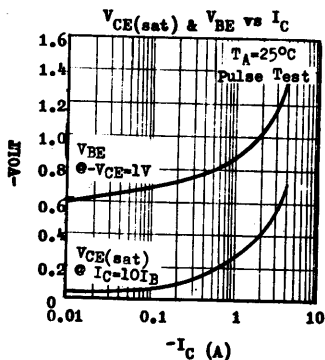
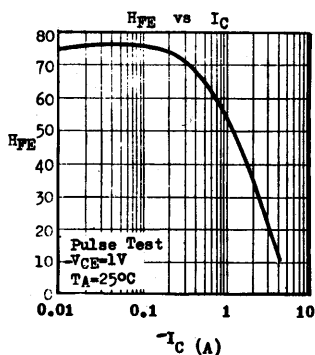

12.77.0870E

EN930 SE4010

NPN SILICON AF LOW NOISE SMALL SIGNAL TRANSISTORS

THE EN930, SE4010 ARE NPN SILICON PLANAR EPITAXIAL TRANSISTORS FOR AF LOW NOISE PREAMPLIFIER APPLICATIONS.

CASE TO-106



CBE

ABSOLUTE MAXIMUM RATINGS

		EN930	SE4010
Collector-Base Voltage	VCBO	45V	30V
Collector-Emitter Voltage	VCEO	45V	25V
Emitter-Base Voltage	VEBO	5V	6V
Collector Current	IC	50mA	50mA
Total Power Dissipation ($T_A \leq 25^\circ\text{C}$)	Ptot	200mW	
		derate 2mW/°C above 25°C	
Operating Junction & Storage Temperature	T_j, T_{stg}	-55 to 125°C	

ELECTRICAL CHARACTERISTICS ($T_A=25^\circ\text{C}$ unless otherwise noted)

PARAMETER	SYMBOL	EN930		SE4010		UNIT	TEST CONDITIONS
		MIN	MAX	MIN	MAX		
Collector-Base Breakdown Voltage	BVCEO	45		30		V	$I_C=0.01\text{mA}$ $I_E=0$
Collector-Emitter Breakdown Voltage	LVCEO	45		25		V	$I_C=10\text{mA}$ (Pulsed) $I_B=0$
Emitter-Base Breakdown Voltage	BVEBO	5		6		V	$I_E=0.01\text{mA}$ $I_C=0$
Collector Cutoff Current	ICES	50				nA	$V_{CE}=45\text{V}$ $V_{BE}=0$
		10				μA	$V_{CB}=45\text{V}$ $V_{BE}=0$ $T_A=100^\circ\text{C}$
Collector Cutoff Current	ICBO			200		nA	$V_{CB}=5\text{V}$ $I_E=0$
				3		μA	$V_{CB}=5\text{V}$ $I_E=0$ $T_A=65^\circ\text{C}$
Emitter Cutoff Current	IEBO	50				nA	$V_{EB}=5\text{V}$ $I_C=0$
Collector-Emitter Saturation Voltage	VCE(sat)	1				V	$I_C=10\text{mA}$ $I_B=0.5\text{mA}$
				0.35		V	$I_C=1\text{mA}$ $I_B=0.1\text{mA}$
Base-Emitter Saturation Voltage	VBE(sat)	0.6	1			V	$I_C=10\text{mA}$ $I_B=0.5\text{mA}$
D.C. Current Gain	HFE	100	300				$I_C=10\mu\text{A}$ $V_{CE}=5\text{V}$
			150				$I_C=500\mu\text{A}$ $V_{CE}=5\text{V}$
			600				$I_C=10\text{mA}$ $V_{CE}=5\text{V}$
Current Gain-Bandwidth Product	f_T			200	1000		$I_C=1\text{mA}$ $V_{CE}=10\text{V}$
		30				MHz	$I_C=0.5\text{mA}$ $V_{CE}=5\text{V}$
				60	300	MHz	$I_C=1\text{mA}$ $V_{CE}=5\text{V}$
Collector-Base Capacitance	Cob		8		4	pF	$V_{CB}=5\text{V}$ $I_E=0$ $f=1\text{MHz}$

PARAMETER	SYMBOL	EN930		SE4010		UNIT	TEST CONDITIONS
		MIN	MAX	MIN	MAX		
Noise Figure	NF	3				dB	$I_C=10\mu A$ $V_{CE}=5V$ $R_G=10K\Omega$ $f=10Hz-10KHz$
				3		dB	$I_C=30\mu A$ $V_{CE}=5V$ $R_G=10K\Omega$ $f=1KHz$
Small Signal Current Gain	h_{fe}	150	600				$I_C=1mA$ $V_{CE}=5V$ $f=1KHz$

TYPICAL CHARACTERISTICS AT $T_A=25^\circ C$

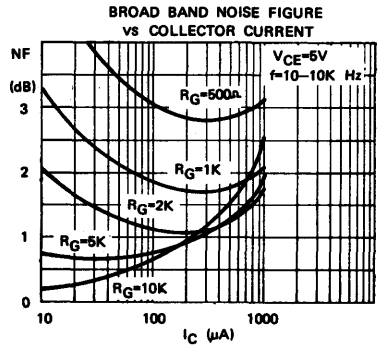
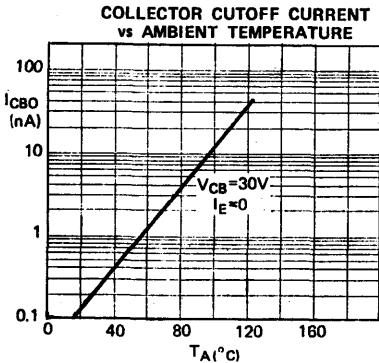
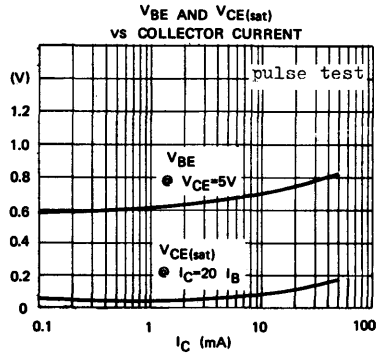
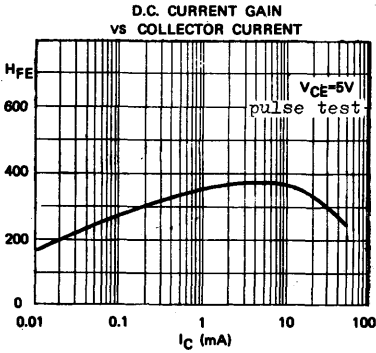

FPT100 FPT100A FPT100B

NPN SILICON PHOTO TRANSISTORS

GENERAL DESCRIPTION

The FPT 100, FPT 100A & FPT 100B are three terminal NPN silicon planar phototransistors. It features high illumination sensitivity, fast response time and low dark current. Besides, the availability of base lead also allows the circuit designer to optimise their design. It is intended for punched cards and paper tape reader, intrusion alarm sensor, position detector and optical tachometer.

ABSOLUTE MAXIMUM RATINGS

Continuous Power Dissipation @ $T_A = 25^\circ\text{C}$, P_{max} (note 1 & 2) 100mW
 Continuous Power Dissipation @ $T_C = 25^\circ\text{C}$, P_{max} (note 1 & 2) 200mW
 Continuous Collector Current, I_C max 25mA
 Collector-Base Voltage; V_{CBO} (note 5) 50V
 Collector-Emitter Sustaining Voltage, V_{CE0} (note 3 & 5) 30V
 Operating Junction Temperature Range, T_J -55 to +85°C
 Storage Temperature Range, T_{stg} -55 to +100°C
 Relative Humidity at Temperature 98% at 65°C

MECHANICAL OUTLINE

TO-106

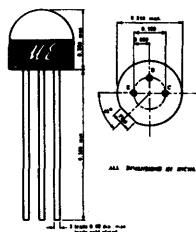

ELECTRICAL CHARACTERISTICS: (@ $T_A = 25^\circ\text{C}$ unless otherwise specified)

PARAMETER	SYMBOL	MIN	TYP	MAX	UNIT	TEST CONDITIONS
Collector-Base Breakdown Voltage	V_{CBO}	50	120		V	$I_C = 100\mu\text{A}$ (note 5)
Collector-Emitter Sustaining Voltage	$V_{CE0(sus)}$	30	50		V	$I_C = 1\text{mA}$ (pulsed) (note 5)
Emitter-Collector Breakdown Voltage	V_{ECCO}	7			V	$I_{EC} = 100\mu\text{A}$ (note 5)
Collector Dark Current	I_{CBO}		0.25	25	nA	$V_{CB} = 10\text{V}$ (note 5)
Collector Dark Current	I_{CBO}		0.025	0.5	μA	$V_{CB} = 10\text{V}$, $T_A = 65^\circ\text{C}$ (note 5)
Collector Dark Current	I_{CEO}		2	100	nA	$V_{CB} = 5\text{V}$ (note 5)
Responsivity (Tungsten)	R_{CBO}	0.6	1.6		$\mu\text{A}/\text{mW}/\text{cm}^2$	$V_{CB} = 10\text{V}$ (notes 3 & 6)
Responsivity (GaAs)	R_{CBO}	1.8	4.8		$\mu\text{A}/\text{mW}/\text{cm}^2$	$V_{CB} = 10\text{V}$ (notes 4 & 6)
Photo Current (Tungsten)	$I_{CE(L)}$					
FPT 100		0.2	1.4		mA	$V_{CE} = 5\text{V}$, $H = 5\text{mW}/\text{cm}^2$
FPT 100A		1		3	mA	(notes 3 & 7)
FPT 100B		1.3		2.6	mA	
Photo Current (GaAs)	$I_{CE(L)}$	0.6	4.2		mA	$V_{CE} = 5\text{V}$, $H = 5\text{mW}/\text{cm}^2$ (notes 4 & 7)
Light Current Rise Time	t_r		2.8		μsec	(note 6)
Light Current Fall Time	t_f		2.8		μsec	(note 6)
Collector-Emitter Saturation Voltage	$V_{CE(sat)}$		0.16	0.3	V	$I_C = 500\mu\text{A}$, $H = 20\text{mW}/\text{cm}^2$

Note 1: These are steady state limits. The factory should be consulted on applications involving pulsed or low duty cycle operations.

Note 2: These ratings give a maximum junction temperature of +85°C and junction to case thermal resistance of +300°C/W (derating factor of 3.33 mW/°C) and a junction to Ambient thermal resistance of +600°C/W (derating factor of 1.67 mW/°C).

Note 3: Measured at noted irradiance as emitted from a tungsten filament lamp at a colour temperature of 2854°K

Note 4: These are values obtained at noted irradiance as emitted from a GaAs source at 0.9 μ .

Note 5: Measured with radiation flux intensity of less than 0.1 $\mu\text{W}/\text{cm}^2$ over the spectrum from 100 to 1500 nm.

Note 6: Rise time is defined as the time required for I_{CE} to rise from 10% to 90% of peak value. Fall time is defined as the time required for I_{CE} to decrease from 90% to 10% of peak value. Test Conditions are: $I_{CE} = 4\text{mA}$, $V_{CE} = 5\text{V}$, $R_L = 100\text{ohm}$, GaAs source.

Note 7: No electrical connection to base lead.

Note 8: No electrical connection to emitter lead.

FPT100 FPT100A FPT100B

TYPICAL ELECTRICAL CHARACTERISTICS

FPT 100 • FPT 100A • FPT 100B

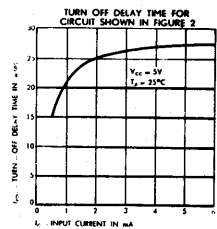
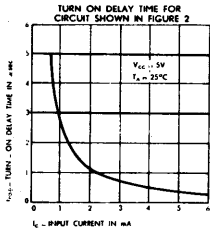
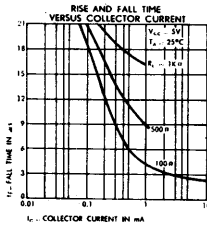
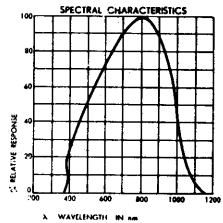
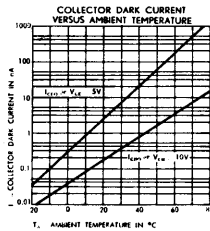
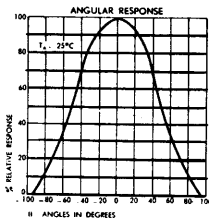
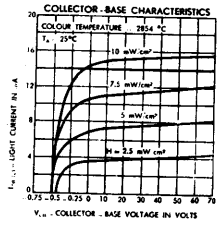
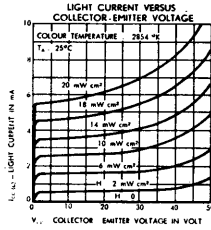
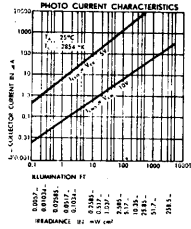

FIGURE 1. SWITCHING CIRCUIT FOR RISE AND FALL TIME.

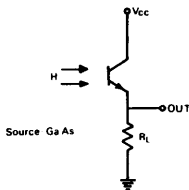
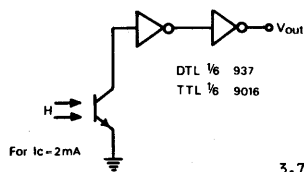

FIGURE 2. CIRCUIT FOR TURN ON AND TURN OFF DATA.



KM PRODUCT LINE

DEVICE SPECIFICATIONS ($T_A = 25^\circ\text{C}$ unless otherwise specified)

TYPE	MAXIMUM RATINGS					ELECTRICAL CHARACTERISTICS												
	I_C	V_{CE0}	V_{CE}	V_{BE}	P_E	$R_{\theta JC}$	$V_{CE(sat)}$	V_{CE}	V_{CE}	I_C/V_{CE}	$V_{CE(sat)}$	I_C/V_{CE}	f_T	f_T	I_C/V_{CE}	Gain @ $V_{CE}=10V$ $I_C=10\mu A$ (dB)	Gain/step 1 (dB/oct)	NF
	(mA)	(V)	(V)	(V)	(mW)	($^{\circ}\text{C}/\text{mW}$)	(mA)	(V)	(V)	(mA/V)	(V)	(mA/V)	(MHz)	(mA/V)	(dB)	(dB)	(dB)	
KM228 (NPN)	80	25	20	3	280	max	typ-max	typ-max	typ-min	typ-max	typ-max	typ	800-850	5/5	0.5-1.3	9-20	2, note 2	
KM318 (NPN)	80	20	12	3	280	80	18	0.73-0.85	1/5	0.14-0.5	10/1	450-250	1/5	1.3-1.7	15-26			
KM317 (NPN)	80	25	20	3	280	80	18	0.67-0.85	1/5	0.05-0.5	10/1	210-150	1/5	1.9-2.5	23-30			
KM001 (NPN)	100	25	20	5	300	50	18	0.63-0.85	1/5	0.05-0.5	10/1	140-80	1/5	2.7-3.5	80-150			
KM014 (NPN)	100	25	20	5	300	50	18	0.63-0.85	1/5	0.07-0.5	10/1	140-50	1/5	2.7-8	180	2, note 3		
KM015 (PNP)	100	25	20	5	300	50	18	0.64-0.85	1/5	0.07-0.5	10/1	120-50	1/5	3.5-6		2, note 3		
KM004 (NPN)	800	25	20	5	800	100	18	0.73	50/1	0.14-0.8	150/15	200	10/5	4-5				
KM234 (NPN)	500	25	20	5	500	100	18	0.73	50/1	0.14-0.8	150/15	120	10/5	4-5				
KM335 (PNP)	500	25	20	5	500	100	18	0.73	50/1	0.2-0.8	150/15	180	10/5	4-5				
KM336 (PNP)	500	25	20	5	500	100	25	0.73	50/1	0.2-0.8	150/15	180	10/5	5				

note 1 : C_{ob} @ $I_C = 1\text{mA}$ $V_{CE} = 6V$ $f = 31.8\text{MHz}$ $f_T = 30\text{MHz}$
 note 2 : NF @ $I_C = 2\text{mA}$ $V_{CE} = 5V$ $R_L = 10\Omega$ $f = 30\text{MHz}$
 note 3 : NF @ $I_C = 0.1\text{mA}$ $V_{CE} = 5V$ $R_L = 10\Omega$ $f = 30\text{Hz}$ to 18kHz

TYPICAL CHARACTERISTICS ($T_A = 25^\circ\text{C}$ unless otherwise specified)

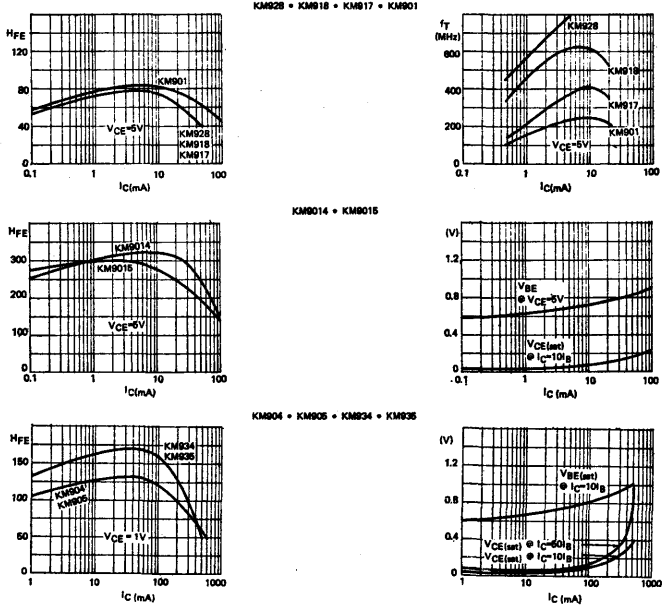

KM PRODUCT LINE

TYPICAL γ - PARAMETERS AT $T_A = 25^\circ\text{C}$

KM928 (Common Base $f = 100\text{MHz}$ $V_{CB} = 5\text{V}$)

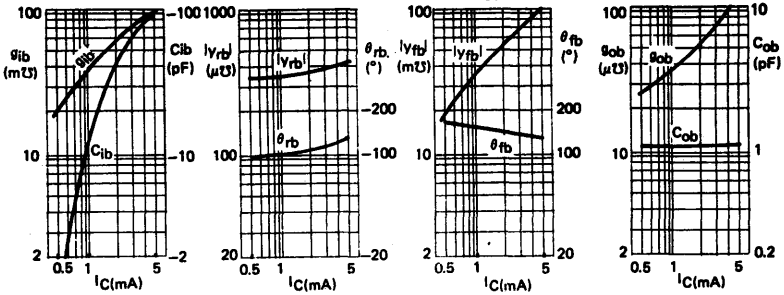

KM918 (Common Base $f = 100\text{MHz}$ $V_{CB} = 5\text{V}$)

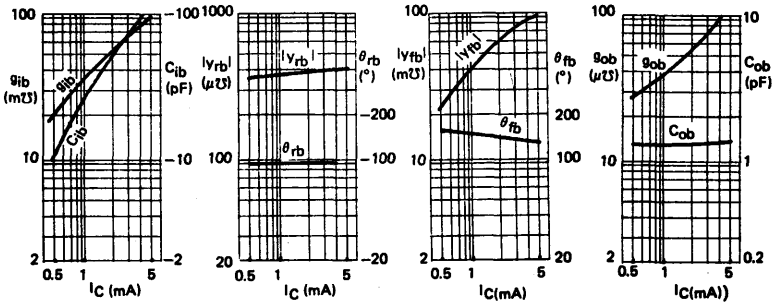

KM917 (Common Emitter $f = 10.7\text{MHz}$ $V_{CE} = 5\text{V}$)

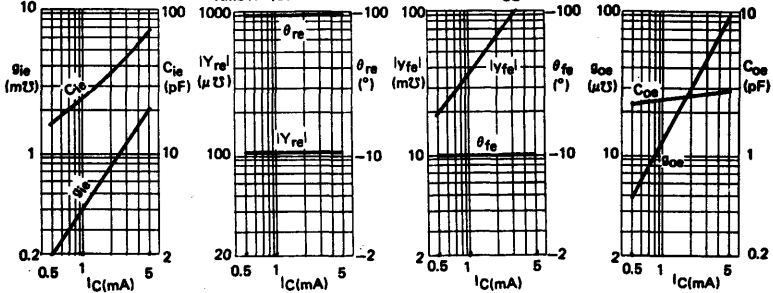

LN9014 LN9015

COMPLEMENTARY

LOW NOISE TRANSISTORS FOR AUDIO PREAMPLIFIERS

The LN 9014 (NPN), LN 9015 (PNP) are complementary silicon passivated planar epitaxial transistors fabricated by low noise technology. They feature high current gain, low noise figure (0.7dB typical at 30Hz - 15KHz) and are best suitable for audio preamplifier applications.

CASE
TO-92A



EBC

ABSOLUTE MAXIMUM RATINGS:

For p-n-p devices, voltage and current values are negative

Collector-Base Voltage	V_{CBO}	30V
Collector-Emitter Voltage	V_{CEO}	25V
Emitter-Base Voltage	V_{EBO}	5V
Collector Current	I_C	100mA
Total Power Dissipation ($T_A=25^\circ\text{C}$)	P_d	300mW
Junction Temperature	T_j	150°C
Storage Temperature Range	T_{stg}	-55 to +150°C

ELECTRICAL CHARACTERISTICS ($T_A=25^\circ\text{C}$)

PARAMETER	SYMBOL	MIN	TYP	MAX	UNIT	TEST CONDITIONS
Collector-Emitter Breakdown Voltage	V_{CE0}	25	50		V	$I_C = 10\text{mA}$ $I_B = 0$
Collector Cutoff Current	I_{CBO}			50	nA	$V_{CB} = 30\text{V}$ $I_E = 0$
Emitter Cutoff Current	I_{EBO}			100	nA	$V_{EB} = 5\text{V}$ $I_C = 0$
Collector-Emitter Saturation Voltage	$V_{CE(sat)}$		0.08	0.25	V	$I_C = 10\text{mA}$ $I_B = 1\text{mA}$
Base-Emitter Voltage	V_{BE}	0.55	0.62	0.75	V	$I_C = 1\text{mA}$ $V_{CE} = 5\text{V}$
D.C. Current Gain	H_{FE1}	100		1000		$I_C = 1\text{mA}$ $V_{CE} = 5\text{V}$
	H_{FE2}	50				$I_C = 10\mu\text{A}$ $V_{CE} = 5\text{V}$
Current Gain-Bandwidth Product	f_T		120		MHz	$I_C = 1\text{mA}$ $V_{CE} = 5\text{V}$
Collector-Base Capacitance, NPN/PNP	C_{ob}		2.4/3.5		pF	$V_{CB} = 10\text{V}$ $I_E = 0$ $f = 1\text{MHz}$
Noise Figure (30Hz - 15 KHz)	NF		0.7	3	dB	$I_C = 0.1\text{mA}$ $V_{CE} = 5\text{V}$ $R_G = 10\text{K ohms}$
Output Noise Voltage (RIAA equalized)	$V_o(N)$		300		μV	See Low Noise Preamplifier Circuit

H_{FE1} is classified as follows. GROUP B: 100-300 GROUP C: 200-600 GROUP D: 400-1000

LN9014 LN9015

TYPICAL CHARACTERISTICS ($T_A=25^\circ\text{C}$ UNLESS OTHERWISE SPECIFIED)

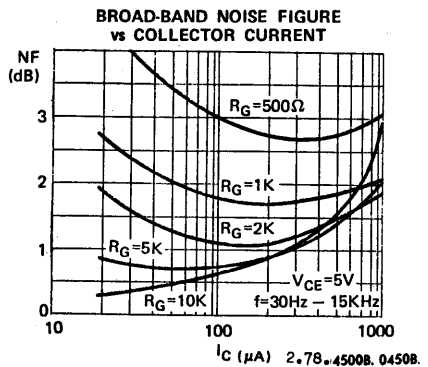
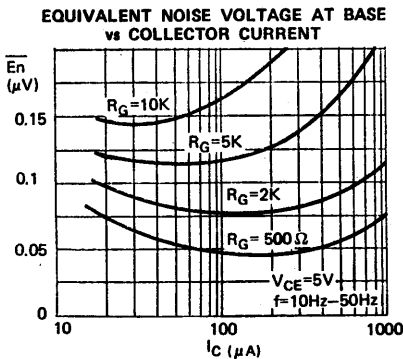
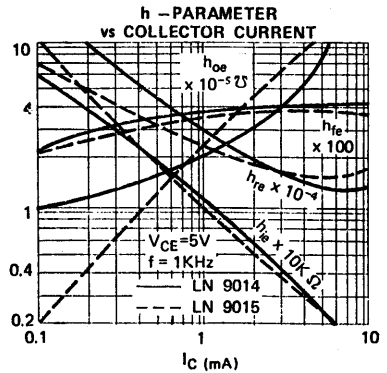
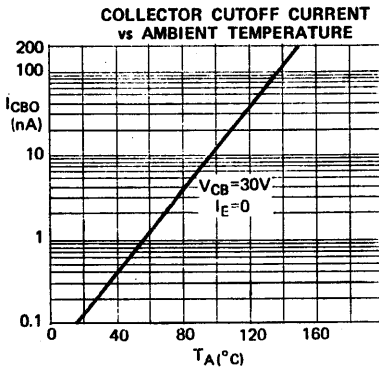
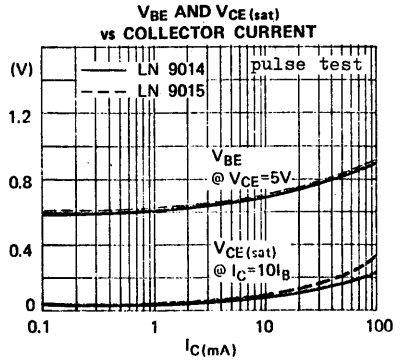
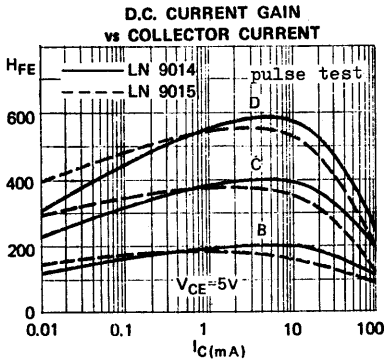

LOW NOISE PREAMPLIFIER CIRCUIT

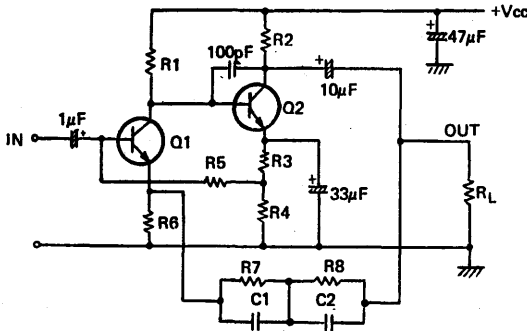

CIRCUIT DETAILS	APPLICATION	
	FOR MAGNETIC CARTRIDGE	FOR CASSETTE TAPE RECORDER
Vcc	+22 V	+5 V
R _L	47 K ohms	10 K ohms
R ₁	180 K ohms	22 K ohms
R ₂	12 K ohms	3.9 K ohms
R ₃	2.7 K ohms	zero
R ₄	820 ohms	2.2 K ohms
R ₅	220 K ohms	220 K ohms
R ₆	390 ohms	560 ohms
R ₇	330 K ohms	68 K ohms
R ₈	27 K ohms	4.7 K ohms
C ₁	0.01 μF	0.022 μF
C ₂	0.003 μF	zero
Q ₁	LN 9014C or D	LN 9014C or D
Q ₂	LN 9014B or C	LN 9014B or C
Frequency Response	RIAA equalized	equalized at 4.75cm/sec.
Input Impedance	200 K ohms	200 K ohms
Max Undistorted Output	4 V rms	0.5 V rms
Voltage Gain	39dB @ 1KHz	30dB @ 400Hz
Total Harmonic Distortion	better than 0.1% @ 1KHz	better than 0.2% @ 400Hz
Output Noise Voltage	300μV @ R _G = 24K ohms	100μV @ R _G = 100 ohms

Note: Reverse polarity of supply voltage and capacitors for PNP transistors LN 9015.

MAS32

PNPN SILICON CONTROLLED SWITCH

The MAS 32 is a Planar PNP Silicon Controlled Switch offering outstanding circuit design flexibility by providing leads to all four semiconductor regions. It is intended for time base circuits and other television applications, also suitable as trigger device for thyristors and as driver for numerical indicator tubes.

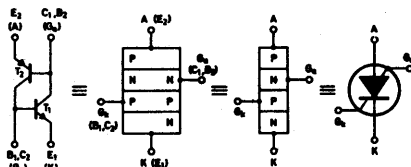

ABSOLUTE MAXIMUM RATINGS

Storage Temperature	-65°C to +150°C
Operating Junction Temperature	150°C
Power Dissipation 25°C ambient	250mW

	NPN	PNP	UNIT
VCBO	70	-70	V
VCEO		-70	V
VEBO	5	-70	V
IE max.	-100	100	mA
IC max. (DC)	50		mA

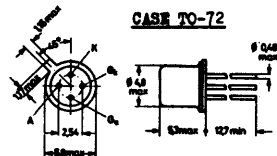

Dimension in mm.
Ga connected to case

ELECTRICAL CHARACTERISTICS (TA=25°C)

Individual NPN Transistor		MIN.	TYP.	MAX.	UNIT
VCE(sat)	Collector Emitter Saturation Voltage IC = 10mA, IB = 1.0mA			500	mV
VBE(sat)	Base Emitter Saturation Voltage IC = 10mA, IB = 1.0mA			900	mV
hFE	D.C. Current Gain IC = 10mA, VCE = 2V	50			
Cc	Collector capacitance IE = Ie = 0, VCB = 20V			5	pf
Ce	Emitter Capacitance IC = Ic = 0, VEB = 1V			30	pf
ICER	Collector Cutoff Current VCE = 70V, RBE = 10kohm			100	nA
IEBO	Emitter Cut Off Current IC = 0, VEB = 5V			1	μA

ELECTRICAL CHARACTERISTICS (T_A = 25°C)

Individual PNP Transistor		MIN.	TYP.	MAX.	UNIT
ICEO	Collector Emitter Cut Off Current I _B = 0, V _{CE} = -70V			-1	μA
IEBO	Emitter Base Cut off Current I _C = 0, V _{EB} = -70V			-10	μA
hFE	D.C. Current Gain I _E = 1mA, V _{CB} = 0	0.25		2.5	
Combined Device : -					
VAK	Forward Voltage (R _{GK} K = 10 κΩ) I _A = 50mA, I _{Ga} = 0 I _A = 1mA, I _{Ga} = 10mA I _A = 50mA, I _{Ga} = 0, T _J = -55°C			1.4 1.2 1.9	V
I _H	Holding Current I _{Ga} = 10mA, V _{BB} = 2.0V, R _{GK} K = 10 Ω	0.1		1.0	mA
t _{on}	Turn on Time when switch from : - -V _{GK} K = 0.5V to +V _{GK} K = 4.5V R _{GK} K = 1 κΩ R _{GK} K = 10 κΩ			0.25 1.5	μS

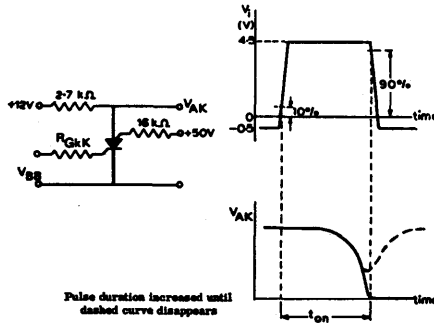

APPLICATION NOTE NO. MEAP 154 IS AVAILABLE

PNP SILICON CONTROLLED SWITCH

The MAS 39 is a Planar PNP Silicon Controlled Switch offering outstanding circuit design flexibility by providing leads to all four semiconductor regions. It is intended for time base circuits and other television applications, also suitable as trigger device for thyristors. The anode gate is connected to case.

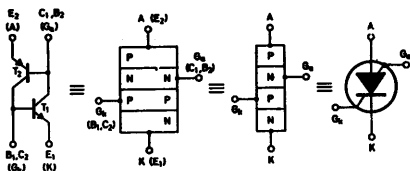

ABSOLUTE MAXIMUM RATINGS

Storage Temperature -65°C to +150°C
 Operating Junction Temperature 150°C
 Power Dissipation 25°C ambient 250mW

	NPN	PNP	UNIT
VCBO	50	-50	V
VCEO		-50	V
VEBO	4	-50	V
IE max.	-100	100	mA
IC max. (DC)	50		mA

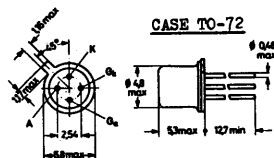

Dimension in mm.
Ga connected to case

ELECTRICAL CHARACTERISTICS (TA = 25°C)

Individual NPN transistor	MIN.	TYP.	MAX.	UNITS
VCE(sat) Collector Emitter Saturation Voltage IC = 10mA, IB = 1.0mA			800	mV
VBESat Base Emitter Saturation Voltage IC = 10mA, IB = 1.0mA			1.0	V
hFE D.C. Current Gain IC = 10mA, VCE = 2V	30			
Ctc Collector capacitance IE = Ie = 0, VCB = 20V			5	pf
Cte Emitter Capacitance IC = Ic = 0, VEB = 1V			30	pf
ICER Collector Cutoff Current VCE = 30V, RBE = 10k ohm			100	nA
IEBO Emitter Cur Off Current IC = 0, VEB = 4V			10	μA

ELECTRICAL CHARACTERISTICS (TA=25°C)

Individual PNP Transistor		MIN.	TYP.	MAX.	UNIT
ICEO	Collector Emitter Cut Off Current IB = 0, VCE = -50V			-10	μA
IEBO	Emitter Base Cut Off Current IC = 0, VEB = -50V			-10	μA
hFE	D.C. Current Gain IE = 1mA, VCB = 0	0.25		2.5	
Combined Device : -					
VAK	Forward Voltage (RGK=10 κΩ) IA = 50mA, IGa = 0 IA = 1mA, IGa = 10mA			1.4 1.2	V V
IH	Holding Current IGa = 10mA, VBB = 2.0V, RGK = 10 κΩ	0.1		1.0	mA
ton	Turn on Time when switch from : - -VGK = 0.5V to +VGK = 4.5V RGK = 1 κΩ RGK = 10 κΩ			0.25 1.5	μS μS

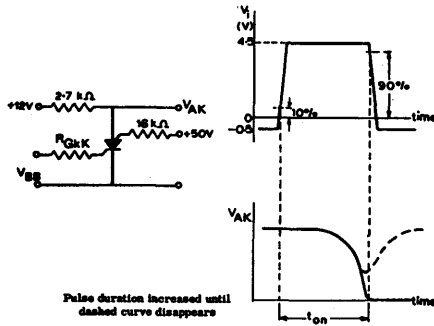

APPLICATION NOTE NO. MEAP 154 IS AVAILABLE

GENERAL DESCRIPTION

The MD8009 is a 40-lead DIP monolithic digital alarm clock utilizing MOS P-channel low-threshold enhancement mode and ion-implanted integrated circuit technology. The timekeeping function operates from line frequency (50 or 60Hz). Four display modes (time, seconds, alarm and sleep) are provided to optimize circuit utility. The circuit interfaces directly with seven-segment displays and provides either a 12-hour or 24-hour format. Outputs consist of display drives, sleep (e.g. timed radio turn-off) and alarm enable. Power failure indication is provided to inform the user that incorrect time is being displayed. Setting the time cancels this indication.

FEATURES

- * 50 or 60Hz inputs
 - * Unregulated power supply
 - * Direct LED/LCD/Tube drive
 - * 12 or 24 hour display format
 - * AM/PM outputs
 - * Leading zero blanking
 - * Power failure indication
 - * Presetable 59-min sleep timer
 - * Fast & slow set controls
 - * Blanking/brightness control capability
 - * Same pin connections as AMI-S1998,
MM5316 & MM5387AA.
- } 12-hour
} format

FIGURE 1. BLOCK DIAGRAM

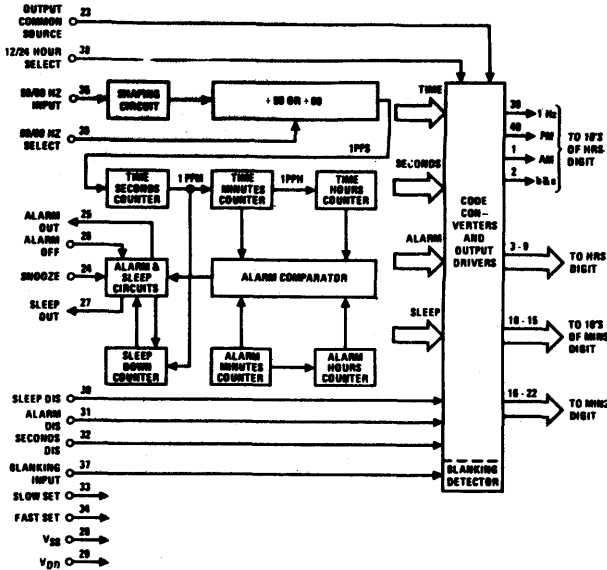
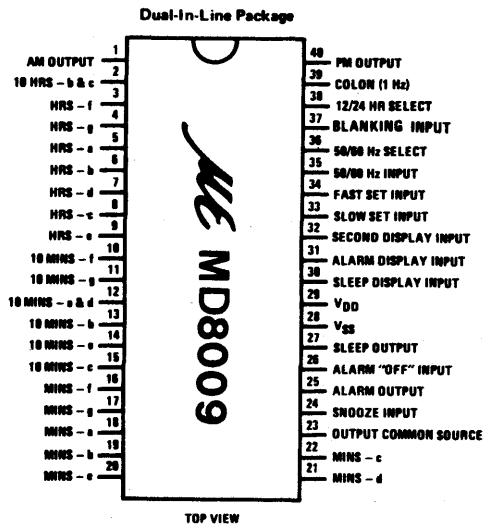

FIGURE 2. CONNECTION DIAGRAM



ABSOLUTE MAXIMUM RATINGS

Voltage at Any Pin

VSS + 0.3V to VSS - 30V

Operating Temperature Range

0°C to + 70°C

Storage Temperature Range

-55°C to +150°C

ELECTRICAL CHARACTERISTICS

TA=0° to 70°C, VSS=15 to 28V, VDD=0 unless otherwise noted)

PARAMETER		MIN	TYP	MAX	UNIT	CONDITIONS
Power Supply Voltage (VSS)		8		28	V	Counter operating
Power Supply Current			1.8 2	4 5	mA mA	VSS= 8V, no output loads VSS=28V, no output loads
Power Failure Detect Voltage		8	11	15	V	AM or PM flashing
50/60Hz Input:						
Frequency		DC	50 or 60	10K	Hz	
Logical High Level		VSS-1		VSS	V	
Logical Low Level		VDD		VDD+1	V	
All Other Input Voltages:						Internal depletion Load to VDD
Logical High Level		VSS-2		VSS	V	
Logical Low Level		VDD		VDD+2	V	
Output Currents	1Hz Output:					
	Logical High Level	1.5			mA	VOH=VSS-2V
	Logical Low Level			1	µA	VOL=VDD
	10's of Hours (b&c) and 10's of Minutes (a&d) :					
Logical High Level	2			mA	VOH=VSS-2V	
Logical Low Level			1	µA	VOL= VDD	
Alarm and Sleep Outputs:						
Logical High Level		3.5			mA	VOH=VSS-2V
Logical Low Level				10	µA	VOL=VDD+0.6V
All Other Display Outputs:						
Logical High Level		5	15		mA	VOH=VSS-2V
Logical Low Level				1	µA	VOL=VDD

FUNCTIONAL DESCRIPTION

A block diagram of the MD8009 digital alarm clock is shown in *Figure 1*. The various display modes provided by this clock are listed in Table I. The functions of the setting controls are listed in Table II. *Figure 2* is a connection diagram. The following discussions are based on *Figure 1*.

50 or 60 Hz Input (pin 35): A shaping circuit is provided to square the 50 or 60 Hz input. This circuit allows use of a filtered sinewave input. The circuit is a Schmitt Trigger that is designed to provide about 6V of hysteresis. A simple RC filter, such as shown in *Figure 5*, should be used to remove possible line-voltage transients that could either cause the clock to gain time or damage the device. The shaper output drives a counter chain which performs the timekeeping function.

50 or 60 Hz Select Input (pin 36): A programmable prescale counter divides the input line frequency by either 50 or 60 to obtain a 1 Hz time base. This counter is programmed to divide by 60 simply by leaving pin 36 unconnected; pull-down to VDD is provided by an internal depletion device. Operation at 50 Hz is programmed by connecting pin 36 to VSS.

Display Mode Select Inputs (pins 30–32): In the absence of any of these three inputs, the display drivers present time-of-day information to the appropriate display digits. Internal pull-down depletion devices allow use of simple SPST switches to select the display mode. If more than one mode is selected, the priorities are as noted in Table I. Alternate display modes are selected by applying VSS to the appropriate pin. As shown in *Figure 1* the code converters receive time, seconds, alarm and sleep information from appropriate points in the clock circuitry. The display mode select inputs control the gating of the desired data to the code converter inputs and ultimately (via output drivers) to the display digits.

Time Setting Inputs (pins 33 and 34): Both fast and slow setting inputs are provided. These inputs are applied either singly or in combination to obtain the control functions listed in Table II. Again, internal pull-down depletion devices are provided; application of VSS to these pins effects the control functions. Note that the control functions proper are dependent on the selected display mode. For example, a hold-time control function is obtained by selecting seconds display and actuating the slow set input. As another example, the clock time may be reset to 12:00:00 AM, in the 12-hour format (00:00:00 in the 24-hour format) by selecting seconds display and actuating both slow and fast set inputs.

Blanking Control Input (pin 37): Connecting this Schmitt Trigger input to VDD places all display drivers in a non-conducting, high-impedance state, thereby inhibiting the display. Conversely, VSS applied to this input enables the display.

Output Common Source Connection (pin 23): All display output drivers are open-drain devices with all sources common to pin 23, VSS or a display brightness control voltage should be permanently connected to this pin. (*Figure 5*).

12 or 24-Hour Select Input (pin 38): By leaving this pin unconnected, the outputs for the most-significant display digit (10's of hours) are programmed to provide a 12-hour display format. An internal depletion pull down device is again provided. Connecting this pin to VSS programs the 24-hour display format. Segment connections for 10's of hours in 24-hour mode are shown in *Figure 3b*.

Power Fail Indication: If the power to the integrated circuit drops indicating a momentary ac power failure and possible loss of clock, the power fail latch is set. The power failure indication consists of a flashing of the AM or PM indicator at a 1 Hz rate. A fast or slow set input resets an internal power failure latch and returns the display to normal. In the 24-hour format, the power failure indication consists of flashing segments "c" and "f" for times less than 10 hours, and of a flashing segment "c" for times equal to or greater than 10 hours but less than 20 hours; and a flashing segment "g" for times equal to or greater than 20 hours.

Alarm Operation and Output (pin 25): The alarm comparator (*Figure 1*) senses coincidence between the alarm counters (the alarm setting) and the time counters (real time). The comparator output is used to set a latch in the alarm and sleep circuits. The latch output enables the alarm output driver that is used to control the external alarm sound generator. The alarm latch remains set for 59 minutes, during which the alarm will therefore sound if the latch output is not temporarily inhibited by another latch set by the snooze alarm input (pin 24) or reset by the alarm "OFF" input (pin 26). If power fail occurs and power comes back up, the alarm output will be in high impedance state.

Snooze Alarm Input (pin 24): Momentarily connecting pin 24 to V_{SS} inhibits the alarm output for between 8 and 9 minutes, after which the alarm will again be sounded. This input is pulled-down to V_{DD} by an internal depletion device. The snooze alarm feature may be repeatedly used during the 59 minutes in which the alarm latch remains set.

alarm "OFF" Input (pin 26): Momentarily connecting pin 26 to V_{SS} resets the alarm latch and thereby silences the alarm. This input is also returned to V_{DD} by an internal depletion device. The momentary alarm "OFF" input also readies the alarm latch for the next comparator output, and the alarm will automatically sound again in 24 hours (or at a new alarm setting). If it is desired to silence the alarm for a day or more, the alarm "OFF" input should remain at V_{SS} .

Sleep Timer and Output (pin 27): The sleep output at pin 27 can be used to turn off a radio after a desired time interval of up to 59 minutes. The time interval is chosen by selecting the sleep display mode (Table I) and setting the desired time interval (Table II). This automatically results in a current-source output via pin 27, which can be used to turn on a radio (or other appliance). When the sleep counter, which counts downwards, reaches 00 minutes, a latch is reset and the sleep output current drive is removed, thereby turning off the radio. The turn off may also be manually controlled (at any time in the countdown) by a momentary V_{SS} connection to the snooze input (pin 24).

TABLE I. MD8009 DISPLAY MODES

*SELECTED DISPLAY MODE	DIGIT NO. 1	DIGIT NO. 2	DIGIT NO. 3	DIGIT NO. 4
Time Display	10's of Hours & AM/PM	Hours	10's of Minutes	Minutes
Seconds Display	Blanked	Minutes	10's of Seconds	Seconds
Alarm Display	10's of Hours & AM/PM	Hours	10's of Minutes	Minutes
Sleep Display	Blanked	Blanked	10's of Minutes	Minutes

* If more than one display mode input is applied, the display priorities are in the order of Sleep (overrides all others), Alarm, Seconds, Time (no other mode selected).

TABLE II. MD8009 SETTING CONTROL FUNCTIONS

SELECTED DISPLAY MODE	CONTROL INPUT	CONTROL FUNCTION
*Time	Slow	Minutes Advance at 2 Hz Rate
	Fast	Minutes Advance at 60 Hz Rate
	Both	Minutes Advance at 60 Hz Rate
Alarm	Slow	Alarm Minutes Advance at 2 Hz Rate
	Fast	Alarm Minutes Advance at 60 Hz Rate
	Both	Alarm Resets to 12:00 AM (Midnight) (12-Hour Format)
	Both	Alarm Resets to 00:00 (24-Hour Format)
Seconds	Slow	Input to Entire Time Counter is Inhibited (Hold)
	Fast	Seconds and 10's of Seconds Reset to Zero Without a Carry to Minutes
	Both	Time Resets to 12:00:00 AM (Midnight) (12-Hour Format)
	Both	Time Resets to 00:00:00 (24-Hour Format)
Sleep	Slow	Subtracts Count at 2 Hz
	Fast	Subtracts Count at 60 Hz
	Both	Subtracts Count at 60 Hz

*When setting time sleep minutes will decrement at rate of time counter, until the sleep counter reaches 00 minutes (sleep counter will not recycle).

FIGURE 3. WIRING TEN'S OF HOUR DIGIT

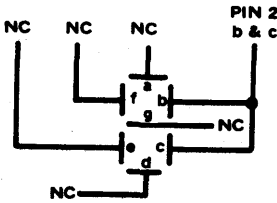

(a) 12-hour display format

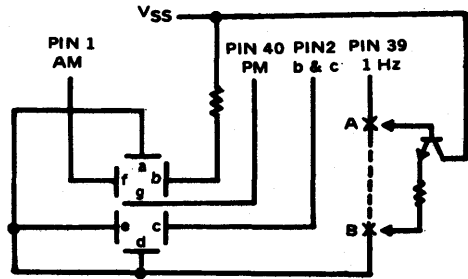

(b) 24-hour display format. An optional NPN can be inserted between A & B to increase the output current of pin 39.

FIGURE 4. PHYSICAL DIMENSIONS IN INCHES

40-lead dural-in-line package

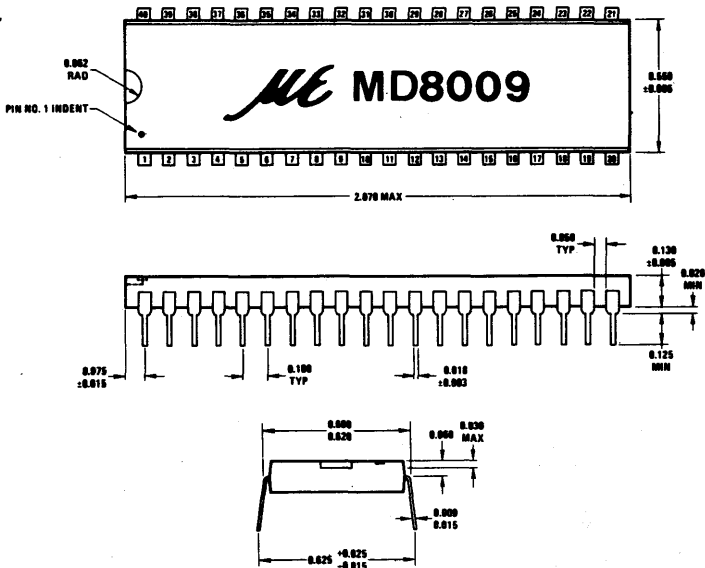
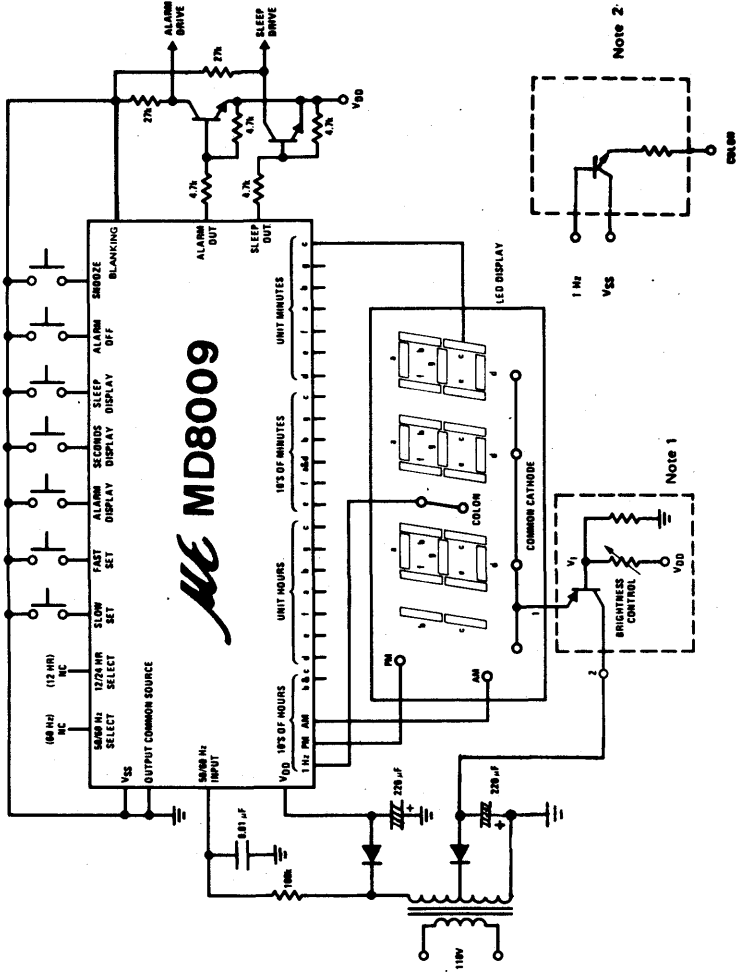

FIGURE 5. TYPICAL APPLICATION: A 12-HR DISPLAY MODE LED ALARM CLOCK



Note 1 :: If brightness control is not required, the emitter-collector terminals (1-2) of the PNP transistor can be disconnected and replaced by a current limiting resistor.

Note 2 :: An NPN transistor can be connected as shown to intensify the colon brightness, if necessary.

FIGURE 6. TYPICAL APPLICATION: A FLUORESCENT TUBE DISPLAY ALARM CLOCK

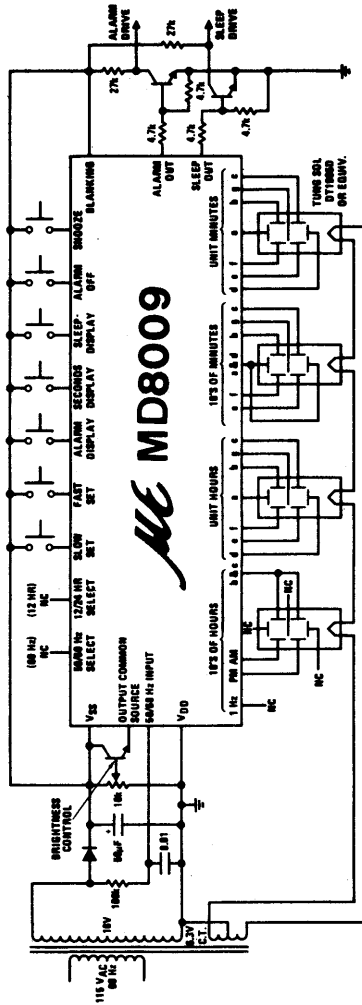

MEL11 MEL12

NPN SILICON PHOTO DARLINGTON TRANSISTORS

THE MEL11, MEL12 ARE NPN SILICON PHOTO DARLINGTON TRANSISTORS FOR USE IN SENSITIVE PHOTO DETECTOR CIRCUITS. THEY ARE SUPPLIED IN SELECTED LIGHT CURRENT GROUPS.

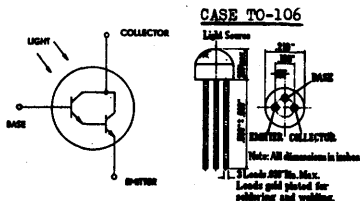

ABSOLUTE MAXIMUM RATINGS

		MEL11	MEL12
Collector-Emitter Voltage	V _{CE0}	30V	25V
Emitter-Collector Voltage	V _{EC0}	5V	5V
Collector Current	I _C	100mA	100mA
Total Power Dissipation (T _A ≤ 25°C)	P _{tot}	300mW	
Operating Junction & Storage Temperature	T _j , T _{stg}	-55 to 100°C	

ELECTRICAL CHARACTERISTICS (T_A=25°C)

PARAMETER	SYMBOL	MEL11			MEL12			UNIT	TEST CONDITIONS
		MIN	TYP	MAX	MIN	TYP	MAX		
Collector-Emitter Breakdown Voltage	V _{CE0} *	30	50	25	40			V	I _C =10mA (Pulsed) I _B =0
Emitter-Collector Breakdown Voltage	V _{EC0} *	5	8.5	5	8.5			V	I _E =0.1mA I _B =0
Collector Cutoff Current (Dark Current)	I _{CE0} *		0.2		0.5			μA	V _{CE} =5V I _B =0
Light Current, Group	I _L **	Group A			Group B			mA	V _{CE} =5V H=2mW/cm ²
		0.5	1	2	1	2	4		
		Group C			Group D				
		3	5	10	7	12	20		
									V _{CE} =5V H=2mW/cm ²

* Tested in complete darkness.

** The light current is the collector to emitter current measured at specified irradiance (H). The radiation source is an unfiltered tungsten filament lamp at 2874°K color temperature.

TYPICAL CHARACTERISTICS AT $T_A=25^\circ\text{C}$

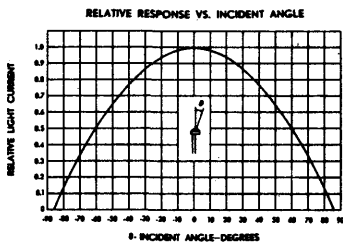
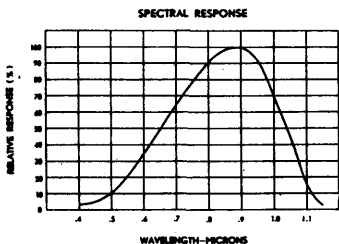
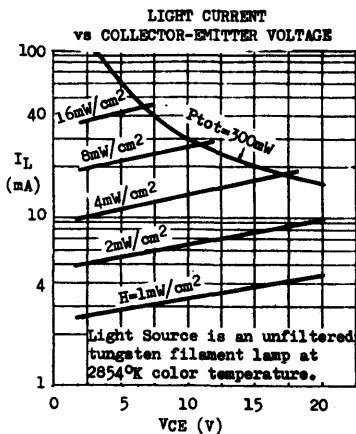
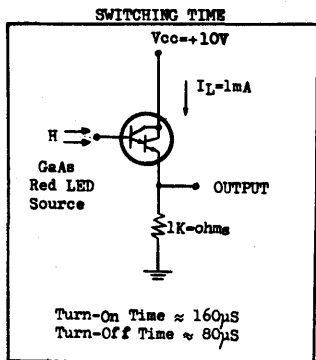

MEL31 MEL32

NPN SILICON PHOTO TRANSISTORS

THE MEL31, MEL32 ARE NPN SILICON PHOTO TRANSISTORS FOR USE IN PHOTO COUPLING CIRCUITS REQUIRING FAST RESPONSE TIME AND LOW DARK CURRENT.

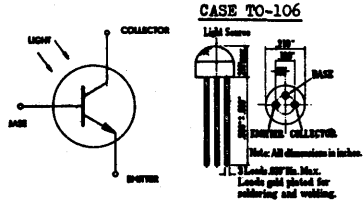

ABSOLUTE MAXIMUM RATINGS

		MEL31	MEL32
Collector-Base Voltage	V _{CE0}	40V	40V
Collector-Emitter Voltage	V _{CE0}	30V	30V
Emitter-Base Voltage	V _{EB0}	6V	6V
Collector Current	I _C	50mA	50mA
Total Power Dissipation (T _A ≤ 25°C)	P _{tot}	200mW	
Operating Junction & Storage Temperature	T _j , T _{stg}	derate 2.67mW/°C above 25°C -55 to 100°C	

ELECTRICAL CHARACTERISTICS (T_A=25°C unless otherwise noted)

PARAMETER	SYMBOL	MEL31		MEL32		UNIT	TEST CONDITIONS
		MIN	TYP MAX	MIN	TYP MAX		
Collector-Base Breakdown Voltage	V _{CE0} *	40		40		V	I _C =0.1mA I _B =0
Collector-Emitter Breakdown Voltage	V _{CE0} *	30		30		V	I _C =10mA (Pulsed) I _B =0
Emitter-Base Breakdown Voltage	V _{EB0} *	6		6		V	I _E =0.1mA I _C =0
Collector Cutoff Current (=Dark Current)	I _{CE0} *	2	50	3	50	nA	V _{CE} =5V I _B =0
		30		50		nA	V _{CE} =5V I _B =0 T _A =65°C
Collector-Emitter Saturation Voltage	V _{CE(sat)} *	0.35		0.35		V	I _C =500μA I _B =25μA
D.C. Current Gain	h _{FE} *	160		280			V _{CE} =5V I _B =1μA
Light Current	I _L **	10	25	30	50	μA	V _{CE} =5V H=2mW/cm ²

* Tested in complete darkness.

** I_L is the collector to emitter current measured at specified irradiance (H) with the base terminal open circuit. The light source is an unfiltered tungsten filament lamp at 2854°K color temperature.

MEL31 MEL32

TYPICAL CHARACTERISTICS AT $T_A=25^\circ\text{C}$

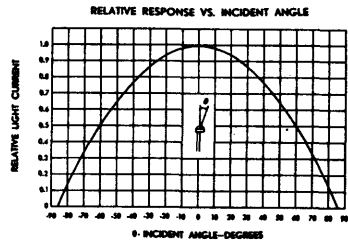
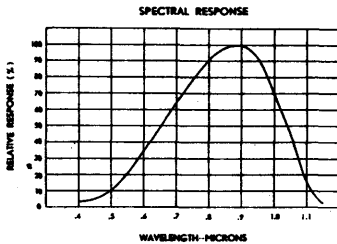
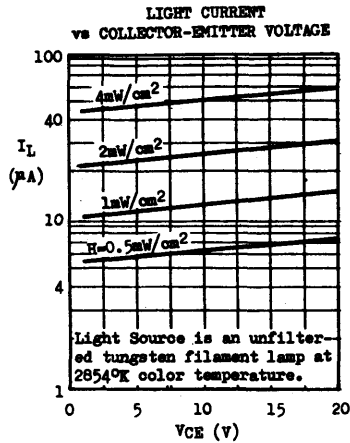
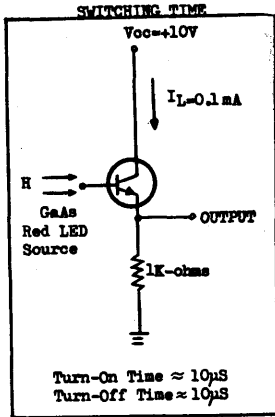

MEU21 MEU22

PROGRAMMABLE UNIJUNCTION TRANSISTORS

The Micro Electronics Programmable Unijunction Transistor (PUT) is a three-terminal planar passivated PNPN device in TO-106 package. The terminals are designated as anode, gate and cathode.

The Micro Electronics PUT offers outstanding circuit design flexibility. External resistors can be selected to meet designers' needs in programming the unijunction characteristics such as η , R_{BB} , I_p and I_v .

The MEU 22 is designed for long interval timers and other applications requiring low peak point current. The MEU 21 is designed for general use where the low peak point current of the MEU 22 is not essential.

For further information, refer to Application Notes Nos. 143, 144 and 158.

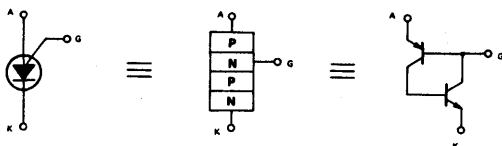

FEATURES

- PROGRAMMABLE η ; R_{BB} ; I_p ; I_v
- LOW LEAKAGE CURRENT
- LOW PEAK POINT CURRENT
- LOW FORWARD VOLTAGE
- HIGH PULSE OUTPUT VOLTAGE
- LOW COST

APPLICATIONS

- OSCILLATORS AND TIMERS
- TRIGGER DEVICES
- LATCHING SWITCHES
- PULSE SHAPING CIRCUITS
- SENSING CIRCUITS
- ELECTRICALLY SIMILAR TO 2N6027 & 2N6028

PACKAGE

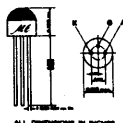

ABSOLUTE MAXIMUM RATINGS

Voltage

Gate-Cathode Forward Voltage	+40 V
Gate-Cathode Reverse Voltage	-5 V
Gate-Anode Reverse Voltage	+40 V
Anode-Cathode Voltage	±40 V

Current

DC Forward Anode Current ²	150 mA
Peak Forward Anode Current, Repetitive (100 μ sec pulse width, 1% duty cycle)	1 A
(20 μ sec pulse width, 1% duty cycle)	2 A

Current

Peak Forward Anode Current, Non-repetitive (10 μ sec pulse)	5 A
DC Gate Current	±20 mA
Capacitive Discharge Energy [†]	250 μ J

Power

Total Average Power ²	300 mW
----------------------------------	--------

Temperature

Operating Ambient ²	-50°C to +100°C
Temperature Range	-50°C to +100°C

²Derate currents and powers 1%/°C above 25°C
[†]E = $\frac{1}{2} CV^2$ capacitor discharge energy with no current limiting

MEU21 MEU22

ELECTRICAL CHARACTERISTICS AT $T_A = 25^\circ\text{C}$ (unless otherwise specified)

CHARACTERISTICS	SYMBOL	FIG. NO.	MEU 21		MEU 22		UNITS	TEST CONDITIONS	
			Min.	Max.	Min.	Max.			
Peak Point Current	I_p	1	2	.15	μA	$V_s = 10\text{ Volts}$	$R_a = 1\text{ Mn}$		
			5	1.0	μA	$V_s = 10\text{ Volts}$	$R_a = 10\text{ K}\Omega$		
Offset Voltage	V_T	1	.2	1.8	.2	.8	Volts	$V_s = 10\text{ Volts}$	$R_a = 1\text{ Mn}$
			.2	.8	.2	.8	Volts	$V_s = 10\text{ Volts}$	$R_a = 10\text{ K}\Omega$
Valley Current	I_V	1	50	25	μA	$V_s = 10\text{ Volts}$	$R_a = 1\text{ Mn}$		
			70	25	μA	$V_s = 10\text{ Volts}$	$R_a = 10\text{ K}\Omega$		
Gate-Anode Leakage Current	I_{GAO}	2	10	10	nA	$V_s = 40\text{ Volts}$	$T_A = 25^\circ\text{C}$ $T_A = 75^\circ\text{C}$		
Gate - Cathode Leakage Current	I_{GKS}	3	100	100	nA	$V_s = 40\text{ Volts}$	$V_A = 0$		
Forward Voltage	V_f	1	1.5	1.5	Volts	$I_f = 50\text{ mA}$			
Pulse Output Voltage	V_o	4	6	6	Volts				
Pulse Voltage Rate of Rise	t_r	4	80	80	nsec.				

Note: MEU21 is electrically similar to 2N6027.
MEU22 is electrically similar to 2N6028.

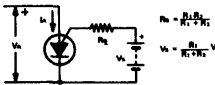
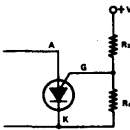

$$R_g = \frac{R_1 R_2}{R_1 + R_2}$$

$$V_g = \frac{R_1}{R_1 + R_2} V$$

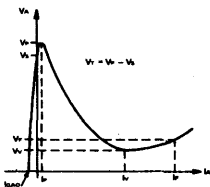

Figure 1

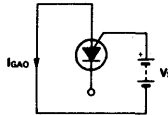

Figure 2

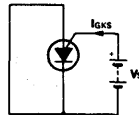

Figure 3

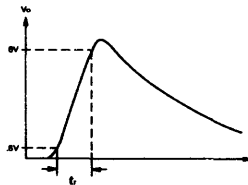
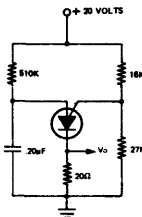
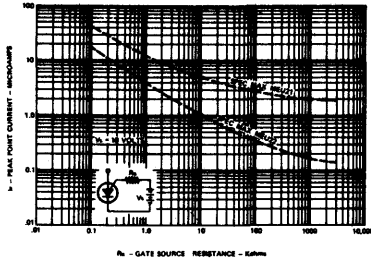
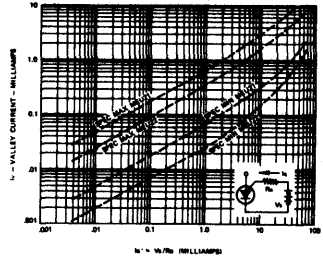

Figure 4

TYPICAL CHARACTERISTICS AT $T_A = 25^\circ\text{C}$ (unless otherwise specified)



I_p VS GATE SOURCE RESISTANCE



I_v VS "ON STATE" GATE CURRENT

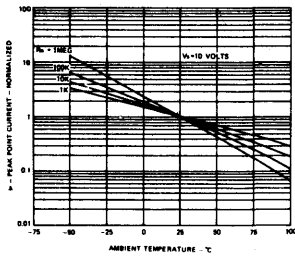

I_p VS TEMPERATURE AND R_g

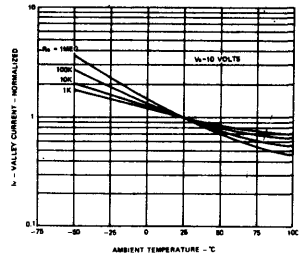

I_v VS TEMPERATURE AND R_g

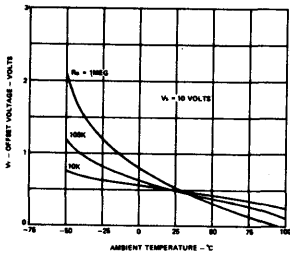

V_o VS TEMPERATURE AND R_g

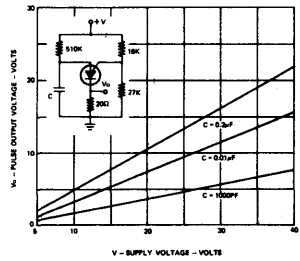

APPLICATIONS

Precision Relaxation Oscillator

The use of the diode 1N4154 and 1 meg resistor at the gate gives low peak point current, therefore reducing the shunting effect of the PUT on C_T during the charging period. The diode also temperature compensates V_{AG} which drifts at about $-2.5\text{mV per }^\circ\text{C}$.

The circuit oscillates at 100Hz which is kept within 1% from -30°C to 75°C .

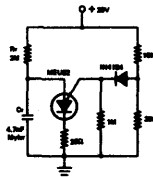

Ten-minute Time Delay Relay

The PUT uses high gate source resistance (1M-ohms) and draws negligible current from the RC network during the delay time. When the SCS is triggered by the PUT, the relay is energized. C is short-circuited by a pair of relay contacts. This condition ensures that accurate timing is repeatable because C is always charged from zero volt after the circuit is reset. Time delay is approximately 10 minutes at $R = 4.7\text{ M-ohms}$.

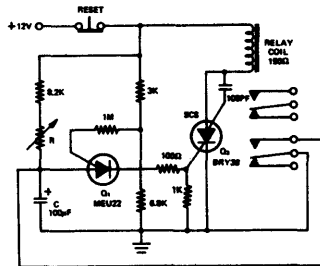

Monostable Multivibrator

The PUT is normally ON. A positive pulse at the input turns Q_1 on, C is discharged rapidly through the saturation resistance of the collector-emitter junction. The PUT becomes OFF. At the removal of the input pulse, Q_1 is cut off. C is charged through R towards +20V. When the peak point voltage is reached, Q_2 fires and returns to the latching state again due to the holding current through R.

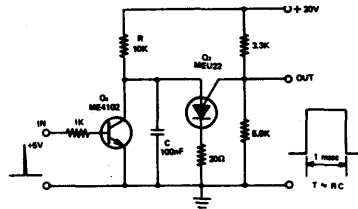

Warble Alarm Circuit

This alarm can be easily heard in noisy background. Q_2 and Q_3 forms a tone generator in which the fundamental frequency is modulated by the sawtooth output of Q_1 .

Tone frequency $\approx (500-800)\text{Hz}$

Sawtooth frequency $\approx 2.5\text{Hz}$

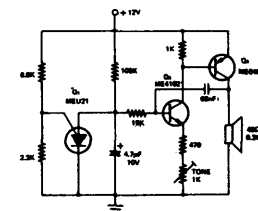

SCR Phase Control

The conduction angle of the SCR is controlled by the PUT oscillator which is synchronized from the a.c. line. This ensures that the SCR is triggered at the same point on the a.c. cycle each time.

The conduction angle of the SCR can be varied from 30° to 160° by using the 100 k-ohm variable resistor.

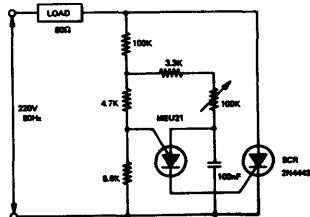

MH7301 MH7302 MH7303

NPN HIGH VOLTAGE HIGH FREQUENCY MEDIUM POWER TRANSISTORS

THE MH7301, MH7302, MH7303 ARE NPN SILICON PLANAR TRANSISTORS DESIGNED FOR HIGH VOLTAGE AND HIGH FREQUENCY MEDIUM POWER APPLICATIONS. THEY ARE CAPABLE TO DISSIPATE 1.25 WATT WITHOUT ANY HEATSINK AT 25°C FREE AIR.

CASE TO-220B



- * FOR TV VIDEO OUTPUT STAGE
- * FOR HIGH VOLTAGE CLASS A AUDIO AMPLIFIER
- * FOR HIGH VOLTAGE SWITCH UP TO 100mA / 250V

ABSOLUTE MAXIMUM RATINGS

		MH7301	MH7302	MH7303
Collector-Base Voltage	V _{CB0}	160V	200V	250V
Collector-Emitter Voltage	V _{CE0}	160V	200V	250V
Emitter-Base Voltage	V _{EB0}		5V	
Collector Current	I _C		100mA	
Collector Peak Current (t ≤ 10μs)	I _{CM}		500mA	
Total Power Dissipation (T _C ≤ 25°C)	P _{tot}		10W	
(T _A ≤ 25°C)			1.25W	
Operating Junction & Storage Temperature	T _j & T _{stg}		-55 to 150°C	

THERMAL RESISTANCE

Junction to Case	θ _{jc}	12.5°C/W	max.
Junction to Ambient	θ _{ja}	100°C/W	max.

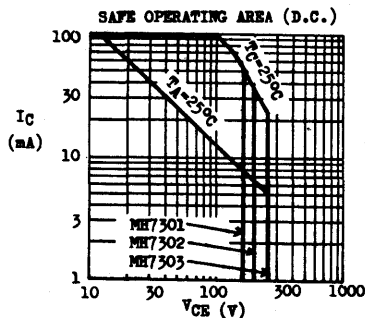
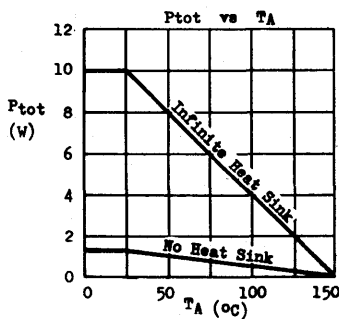

MH7301 MH7302 MH7303

ELECTRICAL CHARACTERISTICS ($T_A=25^\circ\text{C}$ unless otherwise noted)

PARAMETER	SYMBOL	MH7301		MH7302		MH7303		UNIT	TEST CONDITIONS
		MIN	MAX	MIN	MAX	MIN	MAX		
Collector-Base Breakdown Voltage	BV_{CBO}	160	200	250				V	$I_C=0.1\text{mA}$ $I_B=0$
Collector-Emitter Breakdown Voltage	BV_{CEO}^*	160	200	250				V	$I_C=10\text{mA}$ $I_B=0$
Collector Cutoff Current	I_{CBO}	0.5	0.1	0.1				μA	$V_{CE}=150\text{V}$ $I_B=0$
Collector Cutoff Current	I_{CEO}	20	5			5		μA	$V_{CE}=150\text{V}$ $I_B=0$ $V_{CE}=200\text{V}$ $I_B=0$
Emitter Cutoff Current	I_{EBO}	0.1	0.1	0.1				μA	$V_{EB}=5\text{V}$ $I_C=0$
Collector-Emitter Saturation Voltage	$V_{CE(sat)}^*$	1.5	1.5	1.5				V	$I_C=30\text{mA}$ $I_B=3\text{mA}$
Base-Emitter Saturation Voltage	$V_{BE(sat)}^*$	1.5	1.5	1.5				V	$I_C=30\text{mA}$ $I_B=3\text{mA}$
D.C. Current Gain	h_{FE}^*	40	40	40					$I_C=30\text{mA}$ $V_{CE}=10\text{V}$
Current Gain-Bandwidth Product	f_T	50	50	50				MHz	$I_C=30\text{mA}$ $V_{CE}=20\text{V}$
Collector-Base Capacitance	C_{ob}	5	5	5				pF	$V_{CB}=30\text{V}$ $I_B=0$ $f=1\text{MHz}$

* Pulse Test : Pulse Width=0.3 μs , Duty Cycle=1%

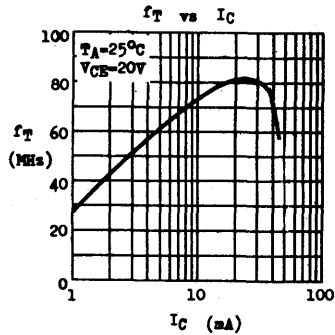
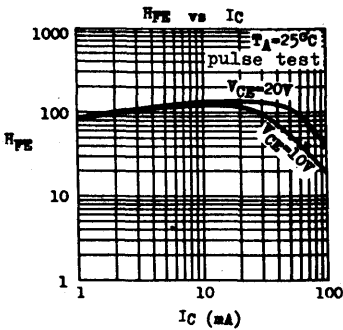

MH8100 MH0810

COMPLEMENTARY EPITAXIAL TRANSISTORS FOR 3-5W AF OUTPUT

The MH8100 (NPN), MH0810 (PNP) are complementary silicon planar epitaxial transistors designed for the output stages of 3-5 watt audio amplifiers. They are also suitable for switches up to 3A collector current.

CASE
TO-220B



BCE

ABSOLUTE MAXIMUM RATINGS:

For p-n-p devices, voltage and current values are negative.

Collector-Emitter Voltage ($V_{BE} = 0$)	V_{CES}	35V
Collector-Emitter Voltage (Base Open)	V_{CEO}	30V
Emitter-Base Voltage	V_{EBO}	5V
Collector Current	I_C	3A
Collector Peak Current ($t \leq 10\text{ms}$)	I_{CM}	5A
Total Power Dissipation ($T_C \leq 25^\circ\text{C}$)	P_{TOT}	12W
Junction Temperature	T_J	150°C
Storage Temperature Range	T_{STG}	-55 to $+150^\circ\text{C}$

ELECTRICAL CHARACTERISTICS ($T_A = 25^\circ\text{C}$)

PARAMETER	SYMBOL	MIN	TYP	MAX	UNIT	TEST CONDITIONS
Collector-Emitter Breakdown Voltage	V_{CEO}	30			V	$I_C = 50\text{mA}$ $I_B = 0$
Collector Cutoff Current	I_{CES}			1	μA	$V_{CE} = 35\text{V}$ $V_{BE} = 0$
Emitter Cutoff Current	I_{EBO}			1	μA	$V_{EB} = 5\text{V}$ $I_C = 0$
Collector-Emitter Saturation Voltage	$V_{CE(sat)}$		0.8		V	$I_C = 2\text{A}$ $I_B = 0.2\text{A}$
Base-Emitter Voltage	V_{BE}			1	V	$I_C = 0.5\text{A}$ $V_{CE} = 2\text{V}$
D.C. Current Gain	h_{FE1}	40		240		$I_C = 0.5\text{A}$ $V_{CE} = 2\text{V}$
	h_{FE2}	30				$I_C = 0.01\text{A}$ $V_{CE} = 2\text{V}$
Current Gain-Bandwidth Product	f_T	30	100		MHz	$I_C = 0.2\text{A}$ $V_{CE} = 4\text{V}$

* h_{FE1} is classified as follows.

Group A : 40-80

Group B : 70-140

Group C : 120-240

MH8100 MH0810

TYPICAL CHARACTERISTICS ($T_A = 25^\circ\text{C}$ UNLESS OTHERWISE SPECIFIED)

RATED POWER vs CASE TEMPERATURE

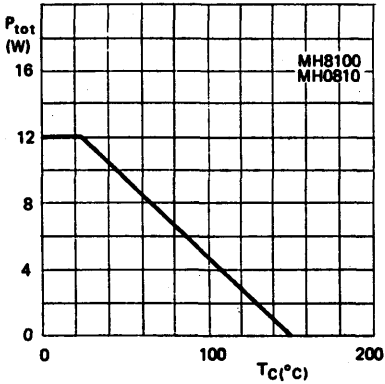

SAFE OPERATING AREA (D.C.)

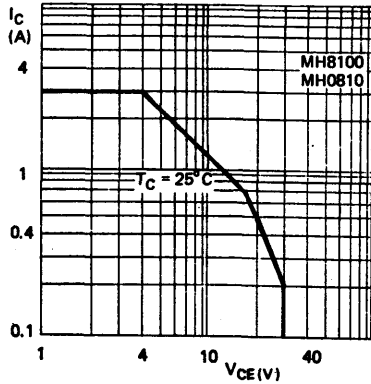

D.C. CURRENT GAIN vs COLLECTOR CURRENT

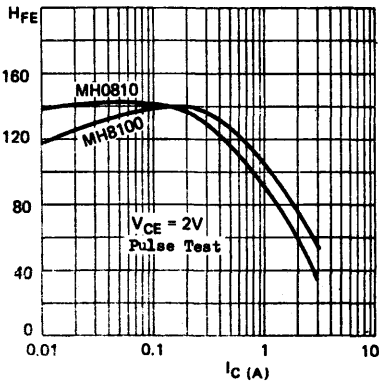

V_{BE} AND $V_{CE(sat)}$ vs COLLECTOR CURRENT

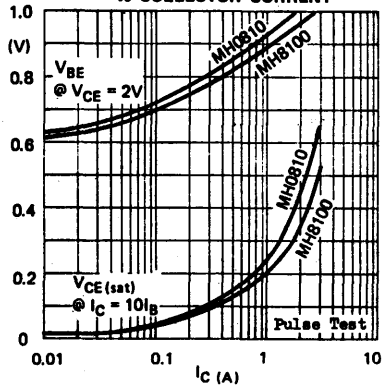

MH8100 MH0810

APPLICATION 1: 3W OTL AUDIO AMPLIFIER

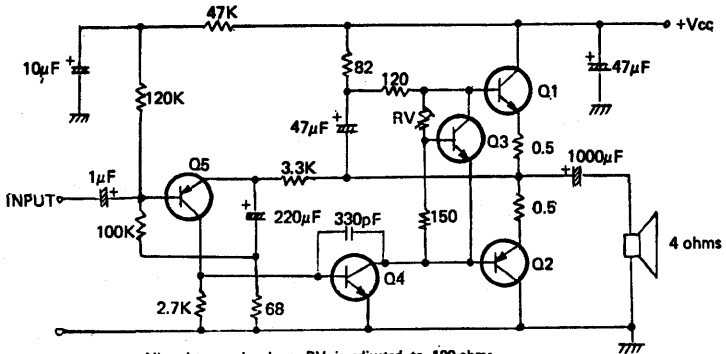

All resistances in ohms. RV is adjusted to 100-ohms at which quiescent collector current of $Q_1 = 5\text{mA}$.

TRANSISTORS

- Q_1 : MH8100, H_{FE} GROUP B to C, mounted on heat sink.
- Q_2 : MH0810, H_{FE} GROUP B to C, mounted on heat sink.
- Q_3 : BC238, H_{FE} GROUP B.
- Q_4 : BC338, any H_{FE} GROUP.
- Q_5 : BC308, H_{FE} GROUP B to C.

CIRCUIT PERFORMANCE

- Supply Voltage : 13.2V (16V @ no signal)
- Max Undistorted Output : 3W @ 1KHz
- Input Sensitivity : 84mV @ 3W output
- Input Impedance : 90K ohms @ 1KHz
- Frequency Response : 37Hz to 55KHz, -3dB
- Total Harmonic Distortion : less than 1% @ 2W output, 1KHz
- Current Drain : 42mA @ no signal
440mA @ 3W output

MH8100 MH0810

APPLICATION 2: 5W OTL AUDIO AMPLIFIER

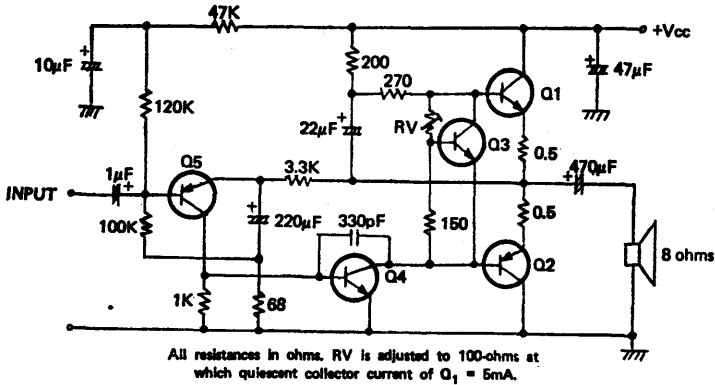

TRANSISTORS

- Q_1 : MH8100, H_F GROUP B to C, mounted on heat sink.
- Q_2 : MH0810, H_{FE} GROUP B to C, mounted on heat sink.
- Q_3 : BC238, H_{FE} GROUP B.
- Q_4 : BC338, any H_{FE} GROUP.
- Q_5 : BC308, H_{FE} GROUP B to C.

CIRCUIT PERFORMANCE

- Supply Voltage : 22V (25V @ no signal)
- Max Undistorted Output : 5.5W @ 1KHz
- Input Sensitivity : 140mV @ 5W
- Input Impedance : 105K ohms @ 1KHz
- Frequency Response : 33Hz to 65KHz, -3dB
- Total Harmonic Distortion : less than 2% @ 5W output, 1KHz
- Current Drain : 32mA @ no signal
390mA @ 5W output

MH8106 MH8108 MH0816 MH0818

NPN PNP SILICON PLANAR EPITAXIAL POWER TRANSISTORS

THE MH 8106, MH 8108 (NPN) AND MH 0816, MH 0818 (PNP) ARE SILICON PLANAR EPITAXIAL TRANSISTORS OF COMPLEMENTARY CHARACTERISTICS. THEY ARE SUITABLE FOR THE DRIVER STAGES OF 30-50WATT AUDIO AMPLIFIERS AND MEDIUM SPEED SWITCHES UP TO 1A COLLECTOR CURRENT.

CASE TO-220B



<u>ABSOLUTE MAXIMUM RATINGS</u>	For p-n-p devices, voltage and current values are negative	MH 8106 (NPN)	MH 8108 (NPN)
		MH 0816 (PNP)	MH 0818 (PNP)
Collector-Base Voltage	V _{CB0}	70V	90V
Collector-Emitter Voltage	V _{CE0}	60V	80V
Emitter-Base Voltage	V _{EB0}		5V
Collector Current	I _C		1A
Collector Peak Current (t < 10μs)	I _{CM}		2A
Total Power Dissipation @ T _C < 25°C	P _{tot}		10W
	@ T _A < 25°C		1.5W
Junction Temperature	T _J		150°C
Storage Temperature Range	T _{stg}		-55 to +150°C

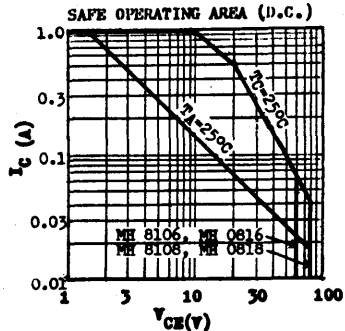
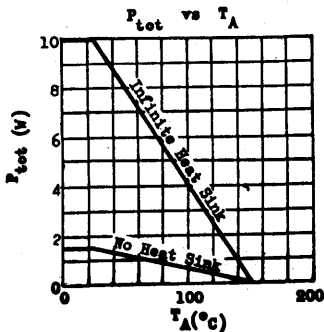

MH8106 MH8108 MH0816 MH0818

ELECTRICAL CHARACTERISTICS ($T_A=25^{\circ}\text{C}$ unless otherwise noted)

PARAMETER	SYMBOL	MIN	TYP	MAX	UNIT	TEST CONDITIONS
Collector-Base Breakdown Voltage MH 8106, MH 0816 MH 8108, MH 0818	BV _{CB0}	70			V	I _C =0.1mA I _B =0
		90			V	
Collector-Emitter Breakdown Voltage MH 8106, MH 0816 MH 8108, MH 0818	LV _{CE0} *	60			V	I _C =10mA I _B =0
		80			V	
Collector Cutoff Current	I _{CBO}			0.5	μA	V _{CB} =60V I _B =0
Emitter Cutoff Current	I _{EB0}			1	μA	V _{EB} =5V I _C =0
Collector-Emitter Saturation Voltage	V _{CE(sat)} *			0.5	V	I _C =500mA I _B =50mA
Base-Emitter Voltage	V _{BE} *			1	V	I _C =500mA V _{CB} =2V
D.C. Current Gain (Note)	H _{FE} 1 *	40		240		I _C =200mA V _{CE} =2V
	H _{FE} 2 *	15				
Current Gain-Bandwidth Product	f _T	50	100		MHz	I _C =100mA V _{CE} =4V
Collector-Base Capacitance MH 8106, MH 8108 MH 0816, MH 0818	C _{ob}			12	pF	V _{CB} =10V I _B =0 f=1MHz
				18	pF	

* Pulse Test : Pulse Width=0.3ms, Duty Cycle=1%

Note : H_{FE} 1 is classified as follows . Group A : 40-80 Group B : 70-140
Group C : 120-240

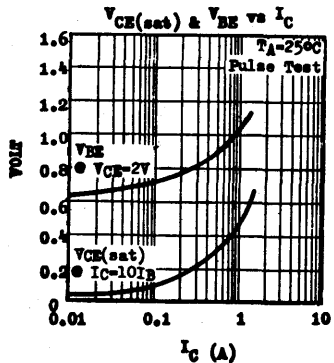
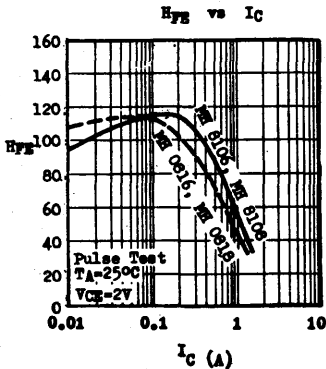

12.77.8100B.0810B

MH8500 MH0850

COMPLEMENTARY EPIBASE TRANSISTORS FOR 20-25W AF OUTPUT

THE MH 8500 (NPN), MH 0850 (PNP) ARE COMPLEMENTARY SILICON POWER TRANSISTORS FABRICATED BY ADVANCED EPIBASE TECHNOLOGY. THEY FEATURE MATCHED COMPLEMENTARY CHARACTERISTICS, HIGH FREQUENCY RESPONSE, GOOD SAFE OPERATING AREA AND ARE BEST SUITABLE FOR THE OUTPUT STAGES OF 20-25W HI-FI AMPLIFIERS. THEY ARE ALSO SUITABLE FOR SWITCHES UP TO 4A COLLECTOR CURRENT.

CASE TO-220B



ABSOLUTE MAXIMUM RATINGS

For p-n-p devices, voltage and current values are negative

Collector-Emitter Voltage ($V_{BE}=0$)	V_{CES}	70V
Collector-Emitter Voltage ($I_B=0$)	V_{CEO}	60V
Emitter-Base Voltage	V_{EBO}	5V
Collector Current	I_C	4A
Collector Peak Current ($t \leq 10ms$)	I_{CM}	8A
Total Power Dissipation ($T_C \leq 25^\circ C$)	P_{tot}	40W
Junction Temperature	T_j	150°C
Storage Temperature Range	T_{stg}	-55 to +150°C

ELECTRICAL CHARACTERISTICS ($T_A=25^\circ C$ unless otherwise noted)

PARAMETER	SYMBOL	MIN	TYP	MAX	UNIT	TEST CONDITIONS
Collector-Emitter Breakdown Voltage	V_{CE0}^*	60			V	$I_C=100mA$ $I_B=0$
Collector Cutoff Current	I_{CES}		10		μA	$V_{CE}=70V$ $V_{BE}=0$
Emitter Cutoff Current	I_{EBO}		10		μA	$V_{EB}=5V$ $I_C=0$
Collector-Emitter Saturation Voltage	$V_{CE(sat)}^*$		0.4	1.2	V	$I_C=3A$ $I_B=0.3A$
Base-Emitter Voltage	V_{BE}^*		1.05	1.5	V	$I_C=3A$ $V_{CE}=2V$
D.C. Current Gain (Note)	$\beta_{FE} 1^*$	40		240		$I_C=1A$ $V_{CE}=2V$
	$\beta_{FE} 2^*$	30				$I_C=0.01A$ $V_{CE}=2V$
	$\beta_{FE} 3^*$	15				$I_C=3A$ $V_{CE}=2V$
Current Gain-Bandwidth Product	f_T	5			MHz	$I_C=0.5A$ $V_{CE}=4V$

* Pulse Test : Pulse Width=0.3ms, Duty Cycle=1%

Note : $\beta_{FE} 1$ is classified as follows . Group A : 40-80 Group B : 70-140
Group C : 120-240

MH8500 MH0850

TYPICAL CHARACTERISTICS

($T_A=25^\circ\text{C}$ unless otherwise noted)

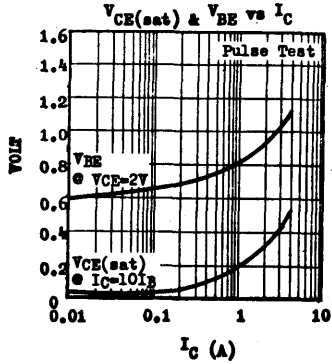
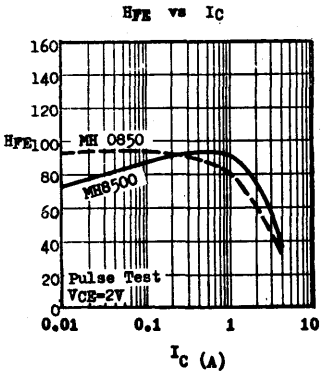
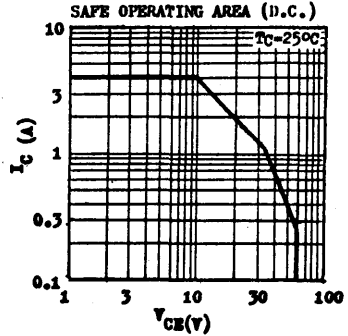
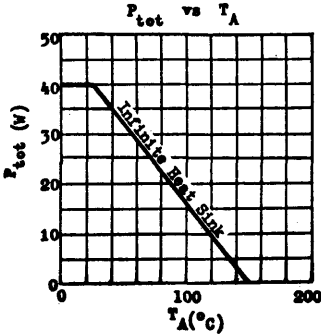

MH8700 MH0870

COMPLEMENTARY EPIBASE TRANSISTORS FOR 10-15W AF OUTPUT

The MH8700 (NPN), MH0870 (PNP) are complementary silicon power transistors fabricated by advanced epi-base technology. They feature matched complementary characteristics, high frequency response, good safe operating area and are best suitable for the output stage of 10-15W Hi-Fi Amplifiers. They are also suitable for switches up to 4A collector current.

CASE
TO-220B



BCE

ABSOLUTE MAXIMUM RATINGS:

For p-n-p devices, voltage and current values are negative

Collector-Emitter Voltage ($V_{BE} = 0$)	V_{CES}	60V
Collector-Emitter Voltage (Base Open)	V_{CEO}	50V
Emitter-Base Voltage	V_{EBO}	5V
Collector Current	I_C	4A
Collector Peak Current ($t \leq 10\text{ms}$)	I_{CM}	7A
Total Power Dissipation ($T_C \leq 25^\circ\text{C}$)	P_{tot}	30W
Junction Temperature	T_j	150°C
Storage Temperature Range	T_{stg}	-55 to +150°C

ELECTRICAL CHARACTERISTICS ($T_A = 25^\circ\text{C}$)

PARAMETER	SYMBOL	MIN	TYP	MAX	UNIT	TEST CONDITIONS
Collector-Emitter Breakdown Voltage	V_{CEO}	50			V	$I_C = 100\text{mA}$ $I_B = 0$
Collector Cutoff Current	I_{CES}		10		μA	$V_{CE} = 60\text{V}$ $V_{BE} = 0$
Emitter Cutoff Current	I_{EBO}		10		μA	$V_{EB} = 5\text{V}$ $I_C = 0$
Collector-Emitter Saturation Voltage	$V_{CE(sat)}$	0.33	0.8		V	$I_C = 2\text{A}$ $I_B = 0.2\text{A}$
Base-Emitter Voltage	V_{BE}	0.82	1.2		V	$I_C = 1\text{A}$ $V_{CE} = 2\text{V}$
D.C. Current Gain	h_{FE1}	40	240			$I_C = 1\text{A}$ $V_{CE} = 2\text{V}$
	h_{FE2}	30				$I_C = 0.01\text{A}$ $V_{CE} = 2\text{V}$
Current Gain-Bandwidth Product	f_T	5			MHz	$I_C = 0.5\text{A}$ $V_{CE} = 4\text{V}$

* h_{FE1} is classified as follows.

Group A : 40-80

Group B : 70-140

Group C : 120-240

MH8700 MH0870

TYPICAL CHARACTERISTICS ($T_A = 25^\circ\text{C}$ UNLESS OTHERWISE SPECIFIED)

RATED POWER vs CASE TEMPERATURE

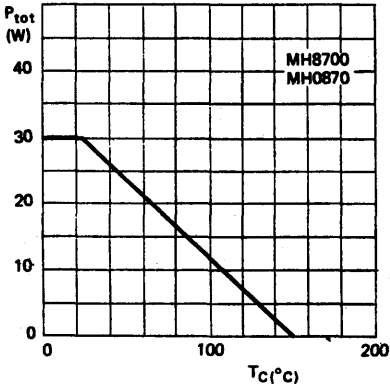

SAFE OPERATING AREA (D.C.)

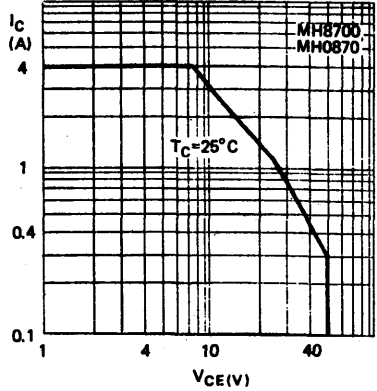

D.C. CURRENT GAIN vs COLLECTOR CURRENT

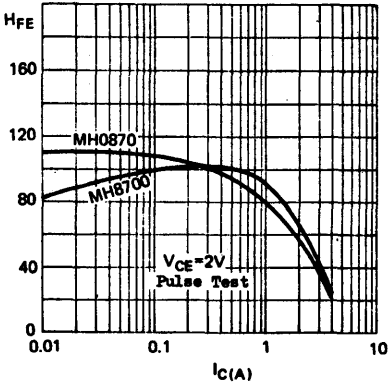

V_{BE} AND $V_{CE(sat)}$ vs COLLECTOR CURRENT

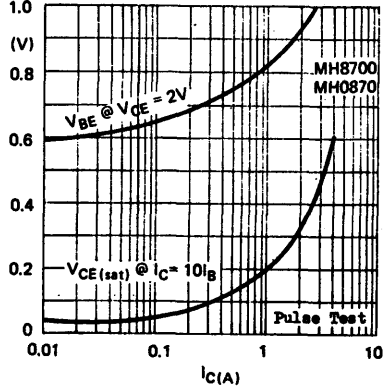

MH8700 MH0870

APPLICATION 1: 10W OTL AUDIO AMPLIFIER

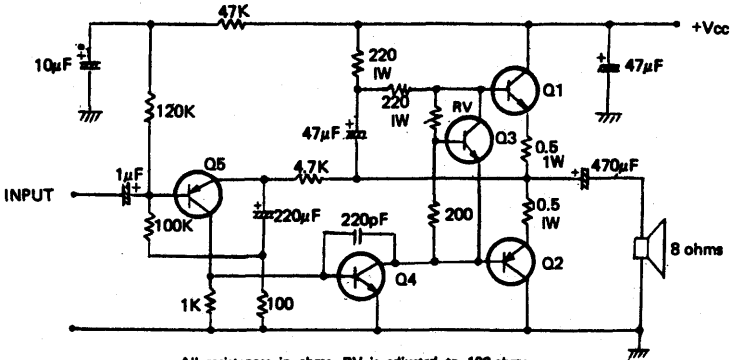

All resistances in ohms. RV is adjusted to 100-ohms at which quiescent collector current of $Q_1 = 5\text{mA}$.

TRANSISTORS

- Q_1 : MH8700, H_{FE} GROUP B to C, mounted on heat sink.
- Q_2 : MH0870, H_{FE} GROUP B to C, mounted on heat sink.
- Q_3 : BC238, H_{FE} GROUP B.
- Q_4 : BC337, With X-67 heat sink mounted on chassis.
- Q_5 : BC308, H_{FE} GROUP B to C.

CIRCUIT PERFORMANCE

Supply Voltage	: 32V (37V @ no signal)
Rated Output	: 10W
Max Undistorted Output	: 11.5W
Input Sensitivity	: 200mV @ 10W output
Input Impedance	: 110 Kohms @ 1kHz
Frequency Response	: 30Hz to 70KHz, -3dB
Total Harmonic Distortion	: less than 0.5% @ 10W, 1KHz
Current Drain	: 50mA @ no signal 580mA @ 10W output

MH8700 MH0870

APPLICATION 2: 15W OTL AUDIO AMPLIFIER

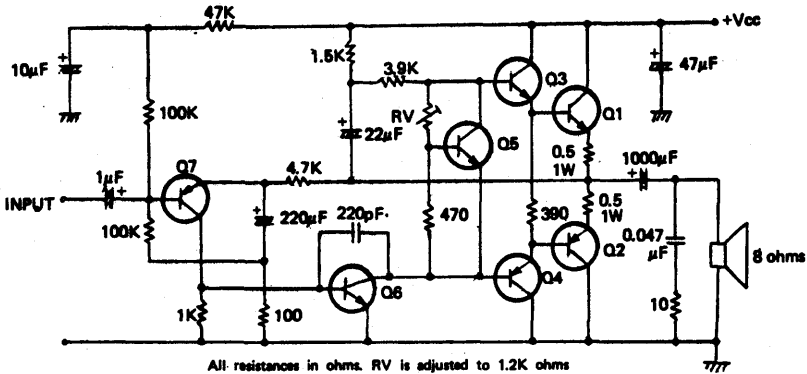

All resistances in ohms. RV is adjusted to 1.2K ohms at which quiescent collector current of Q₁ = 5mA.

TRANSISTORS

- Q₁ : MH8700, H_{FE} GROUP A to B, mounted on heat sink.
- Q₂ : MH0870, H_{FE} GROUP A to B, mounted on heat sink.
- Q₃ : BC182, H_{FE} GROUP A to B.
- Q₄ : BC212, H_{FE} GROUP A to B.
- Q₅ : BC238, H_{FE} GROUP B.
- Q₆ : BC237, H_{FE} GROUP A to B.
- Q₇ : BC307, H_{FE} GROUP B.

CIRCUIT PERFORMANCE

Supply Voltage	: 38V (44V @ no signal)
Rated Output	: 15W
Max Undistorted Output	: 16.5W
Input Sensitivity	: 230mV @ 15W output
Input Impedance	: 100Kohms @ 1kHz
Frequency Response	: 17Hz to 56kHz, -3dB 34Hz to 36kHz, -1dB
Total Harmonic Distortion	: less than 0.1% @ 15W output, 1KHz less than 0.3% @ 15W output, 10KHz
Current Drain	: 20mA @ no signal 630mA @ 15W output

1.7B, 8700E, 0870E

ML555

PRECISION TIMER

FEATURES

- Timing from microseconds through hours
- Monostable and astable operations
- Adjustable duty cycle
- Current output can source or sink 200mA
- Output can drive TTL
- Temperature stability of 0.005% per °C
- Normally on and normally off output

APPLICATIONS

- Precision timing
- Pulse generation
- Sequential timing
- Time delay generation
- Pulse width modulation
- Pulse position modulation
- Missing pulse detector

DESCRIPTION

The ML555 monolithic integrated circuit is a highly stable timer for precision timing and oscillator applications. Additional terminals are provided for triggering or resetting if desired. As a timer, the ML555 is capable of producing accurate time delay from microseconds through hours. As an oscillator, the free running frequency and the duty cycle are both accurately controlled with two external resistors and one capacitor.

The ML555 may be triggered and reset on falling waveforms and the output can drive TTL circuits with source or sink current up to 200mA.

BLOCK DIAGRAM

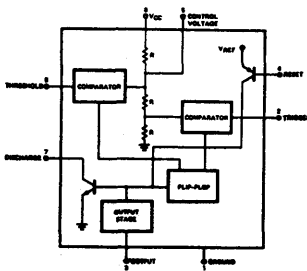

SCHEMATIC DIAGRAM

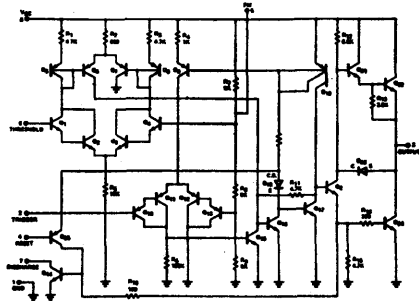

ORDERING INFORMATION

Package Type	Temperature Range	Order Number
MINI DIP	0°C to +70°C	ML 555V
TO - 99	0°C to +70°C	ML 555T

PIN CONFIGURATIONS (TOP VIEW)

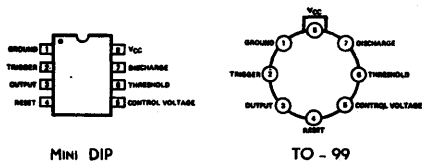

ABSOLUTE MAXIMUM RATINGS

Supply Voltage	+18V
Power Dissipation	600mW
Operating Temperature Range	0°C to +70°C
Storage Temperature Range	-65°C to +150°C
Lead Temperature (Soldering, 60 seconds)	+300°C

ELECTRICAL CHARACTERISTICS ($T_A = 25^\circ\text{C}$, $V_{CC} = +5\text{V}$ to $+15\text{V}$ unless otherwise specified)

PARAMETER	MIN.	TYP.	MAX.	UNITS	TEST CONDITIONS
Supply Voltage	4.5		16	V	
Supply Current		3 10	6 15	mA mA	Low State Output, Note 1 $V_{CC} = 5\text{V}$, $R_L = \infty$ $V_{CC} = 15\text{V}$, $R_L = \infty$
Timing Error					$R_A, R_B = 1\text{K}\Omega$ to $100\text{K}\Omega$, $C = 0.1\mu\text{F}$, Note 2
Initial Accuracy		1.0		%	
Drift with Temperature		50		ppm/°C	
Drift with Supply Voltage		0.1		%/V	
Threshold Voltage		2/3		$\times V_{CC}$	
Trigger Voltage		1/3		$\times V_{CC}$	
Trigger Current		0.5		μA	
Reset Voltage	0.4	0.7	1.0	V	
Reset Current		0.1		mA	
Threshold Current		0.1	0.25	μA	Note 3
Control Voltage Level	2.6 9.0	3.33 10.0	4.0 11.0	V V	$V_{CC} = 5\text{V}$ $V_{CC} = 15\text{V}$
Output Voltage (Low)		0.25 0.1 0.4 2.0 2.5	0.35 0.25 0.75 2.5	V V V V V	$V_{CC} = 5\text{V}$ $I_{\text{sink}} = 5.0\text{mA}$ $V_{CC} = 15\text{V}$ $I_{\text{sink}} = 10\text{mA}$ $I_{\text{sink}} = 50\text{mA}$ $I_{\text{sink}} = 100\text{mA}$ $I_{\text{sink}} = 200\text{mA}$
Output Voltage (High)	2.75 12.75	3.3 13.3		V V V	$I_{\text{source}} = 100\text{mA}$ $V_{CC} = 5\text{V}$ $V_{CC} = 15\text{V}$ $I_{\text{source}} = 200\text{mA}$ $V_{CC} = 15\text{V}$
Rise Time of Output		100		ns	
Fall Time of Output		100		ns	

NOTES:

- Supply current when output high is typically 1mA less.
- Tested at $V_{CC} = 5\text{V}$ and $V_{CC} = 15\text{V}$.
- This will determine the maximum value of $R_A + R_B$. For 15V operation, the maximum total $R = 20\text{M}\Omega$.

TYPICAL CHARACTERISTICS

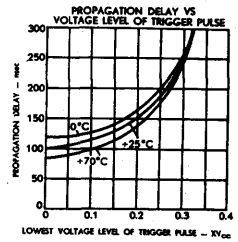
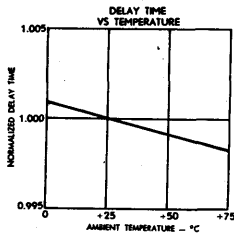
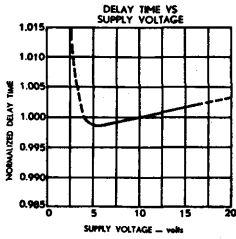
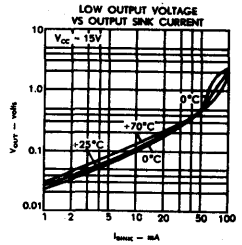
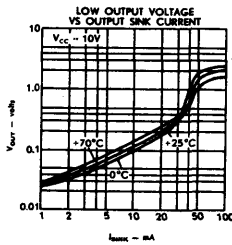
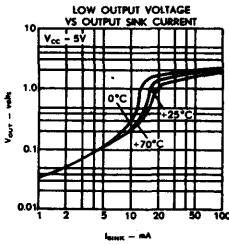
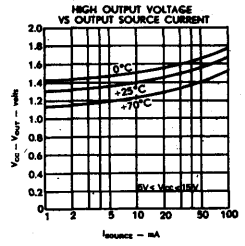
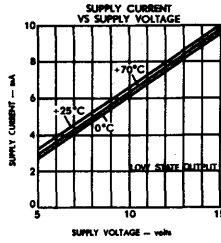
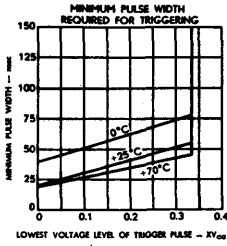

APPLICATION INFORMATION

Monostable Operation

When the timer is operated as a monostable multivibrator, one external capacitor, C, and one external resistor, R_A , are used as shown in Figure 1. When the trigger input is reduced below $1/3 V_{CC}$, the timer internal flip-flop is set. This releases the short circuit across the external capacitor and the output goes HIGH. The voltage across the capacitor begins to rise exponentially with the time constant $R_A C$. When the capacitor voltage reaches $2/3 V_{CC}$, the internal comparator resets the flip-flop and the external capacitor, C, is rapidly discharged provided the trigger voltage is returned above $1/3 V_{CC}$. The output is now in LOW state and a new timing cycle may be initiated. The time that the output is in the HIGH state is given by $1.1 R_A C$ or can be taken directly from Figure 2. Both the charge rate and internal threshold are directly proportional to the V_{CC} supply voltage. Thus, the timer output pulse width is independent of the power supply voltage. If a LOW is applied to the reset input, the output is forced LOW and the external capacitor discharged regardless of the other inputs.

When the reset function is not in use, it is recommended that PIN 4 connected to V_{CC} to avoid any possibility of false triggering.

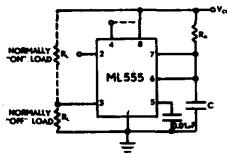

Fig. 1 Monostable Operation

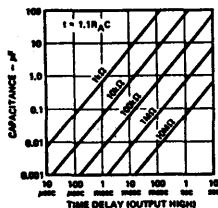

Fig. 2. Monostable Pulse Width.

Astable Operation

When the timer is operated in the astable mode, two external resistors, R_A and R_B , and one external capacitor, C, are used as shown in Figure 3. With this connection, it will trigger itself and free run as a multivibrator. The external capacitor charges through $R_A + R_B$ and discharges through R_B only. Thus the duty cycle may be precisely set by the ratio of these two resistors. In this mode of operation, the capacitor charges and discharges between $1/3 V_{CC}$ and $2/3 V_{CC}$. As in the triggered mode, the charge and discharge times, and therefore the frequency are independent of the supply voltage.

The charge time (output high) is given by $t_1 = 0.693 (R_A + R_B) C$

And the discharge time (output low) by:

$$t_2 = 0.693 (R_B) C$$

Thus the total period is:

$$T = t_1 + t_2 = 0.693 (R_A + 2R_B) C$$

The frequency of oscillation is:

$$f = \frac{1}{T} = \frac{1.44}{(R_A + 2R_B) C}$$

The duty cycle is:

$$D = \frac{R_B}{R_A + 2R_B}$$

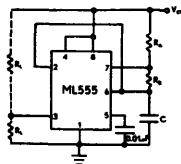

Fig. 3 Astable Operation

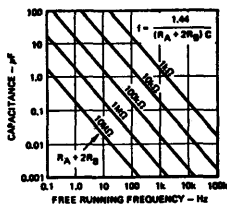
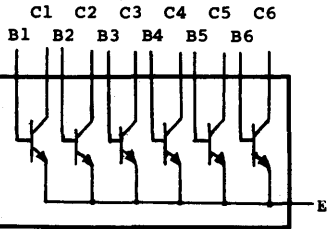

Fig. 4. Astable Free Running Frequency.

ML1060

SIX-DIGIT LED DISPLAY DRIVER

SCHEMATIC DIAGRAM



GENERAL DESCRIPTION

The ML1060 is a monolithic silicon chip consisting of six NPN common-emitter transistors. It features low leakage, low $V_{CE(sat)}$, small chip size and CMOS compatible.

The ML1060 is designed for use as an LED/CMOS digit driver interface in electronic watch systems and calculators using common-cathode multiplexed LED displays. Wire bonding by hybrid assemblers is facilitated by the large, well spaced 5x5 mils bonding pads.

For silicon chip in plastic dual-in-line package, please order part no. ML1060-DIP.

CHIP

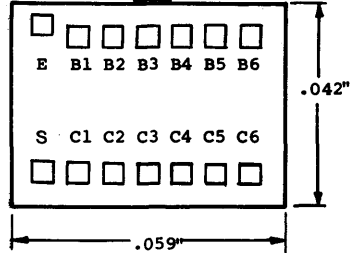

DIP TYPE (TOP VIEW)

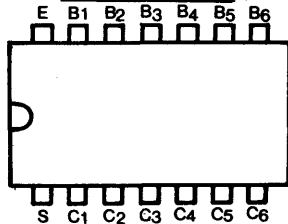

Note: The S-terminal (substrate) must be connected to a voltage which is more negative than any collector voltage.

ABSOLUTE MAXIMUM RATINGS (DIP TYPE)

Any one transistor :

Collector-Emitter Voltage	9V
Emitter-Base Voltage	4V
Collector Current	300mA
Base Current	30mA
Collector Dissipation ($T_A \leq 25^\circ\text{C}$)	500mW

Total Package Dissipation ($T_A \leq 25^\circ\text{C}$) 750mW

Operating Temperature Range -25 to 85°C

Storage Temperature Range -55 to 150°C

ELECTRICAL CHARACTERISTICS PER TRANSISTOR ($T_A=25^{\circ}\text{C}$)

PARAMETER	SYMBOL	MIN	TYP	MAX	UNIT	TEST CONDITIONS
Collector-Emitter Breakdown Voltage	V_{CE0}	9	17		V	$I_C=1\text{mA}$ $I_B=0$
Emitter-Base Breakdown Voltage	V_{EB0}	4	7		V	$I_B=0.1\text{mA}$ $I_C=0$
Collector Cutoff Current	I_{CER}		0.25		μA	$V_{CE}=4\text{V}$ $R_{EB}=10\text{k}\Omega$
Collector-Emitter Saturation Voltage	$V_{CE(sat)}$	0.25	0.4		V	$I_C=63\text{mA}$ $I_B=6.3\text{mA}$
Base-Emitter Voltage	V_{BE}	0.87	1.0		V	$I_B=1\text{mA}$ $V_{CE}=2.4\text{V}$
D.C. Current Gain	h_{FE}	20	65			$I_C=63\text{mA}$ $V_{CE}=2.4\text{V}$
Current Gain-Bandwidth Product	f_T		300		MHz	$I_C=50\text{mA}$ $V_{CE}=2.4\text{V}$
Output Capacitance	C_{ob}		11		pF	$V_{CE}=2\text{V}$ $I_B=0$ $f=1\text{MHz}$

TYPICAL CHARACTERISTICS ($T_A=25^{\circ}\text{C}$)

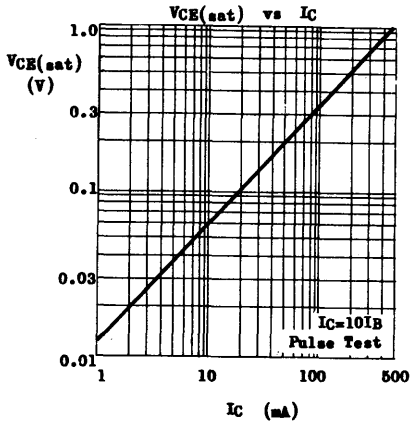
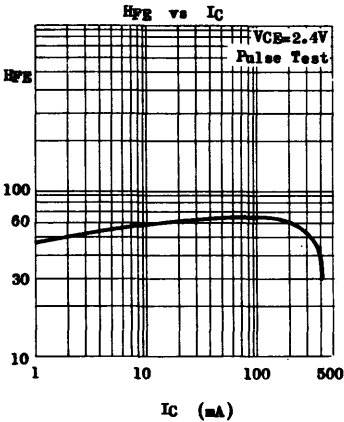

5V - 200MA POSITIVE VOLTAGE REGULATOR

FEATURES

- * LOW INPUT VOLTAGE REQUIREMENT
- * LOW OUTPUT IMPEDANCE
- * OUTPUT SHORT CIRCUIT PROTECTION
- * HIGH TEMPERATURE STABILITY
- * AVAILABLE IN CASE TO-39 / TO-220B

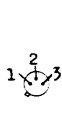
CASE TO-39CASE TO-220B

1. Input
2. Output
3. Ground

132

ORDER PART NO.
ML2005C

ORDER PART NO.
ML2005P

ABSOLUTE MAXIMUM RATINGS

		ML2005C	ML2005P
Input Voltage	V_I	20V	20V
Total Power Dissipation ($T_C \leq 25^\circ\text{C}$) ($T_A \leq 25^\circ\text{C}$)	P_{tot}	5W 0.9W	12W 1.5W
Junction Temperature	T_j	175°C	150°C
Operating Temperature Range	T_{op}	-25 to 85°C	-25 to 85°C
Storage Temperature Range	T_{stg}	-65 to 175°C	-55 to 150°C

THERMAL RESISTANCE

Junction to Case	θ_{jc}	30°C/W max.	10.4°C/W max.
Junction to Ambient	θ_{ja}	167°C/W max.	83.3°C/W max.

ELECTRICAL CHARACTERISTICS ($T_A=25^\circ\text{C}$ unless otherwise noted)

PARAMETER	SYMBOL	MIN	TYP	MAX	UNIT	TEST CONDITIONS *
Output Voltage	V_O	4.5	5	5.25	V	$V_I=7V$ $I_O=150\text{mA}$ $V_I=10V$ $I_O=150\text{mA}$
Load Regulation	ΔV_O		20	100	mV	$V_I=10V$ $I_O=5-150\text{mA}$
Line Regulation	ΔV_O		20	100	mV	$I_O=150\text{mA}$ $V_I=7.5-15V$
Quiescent Current	I_Q		20	30	mA	$V_I=10V$ $I_O=0$
Output Short Circuit Current	I_{SC}		220	300	mA	$V_I=10V$ $V_O=0$
Ripple Rejection ($f=100\text{Hz}$)	$\Delta V_I/\Delta V_O$	38	55		dB	$I_O=150\text{mA}$ $V_I=9-11V$
Output Resistance	R_O		0.1		ohm	$V_I=10V$ $I_O=150\text{mA}$
Output Noise Voltage	$\overline{E_N}$		40		μV	$V_I=10V$ $f=10\text{Hz}-100\text{KHz}$ $I_O=150\text{mA}$
Temperature Coefficient	$\Delta V_O/\Delta T_A$		0.85		mV/°C	$V_I=10V$ $I_O=5\text{mA}$ $T_A=0-70^\circ\text{C}$

* Test duration less than 10 Sec.

TYPICAL CHARACTERISTICS ($T_A=25^\circ\text{C}$ unless otherwise noted)

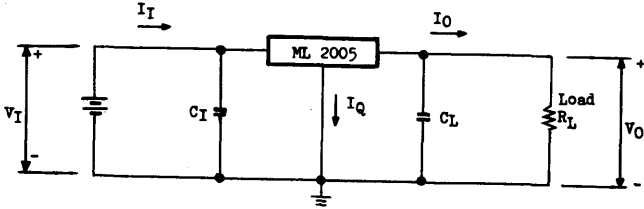

Test duration less than 10sec.

C_I and C_L greater than μF .

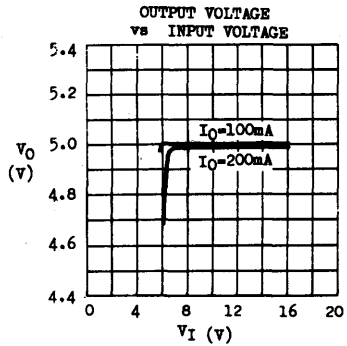
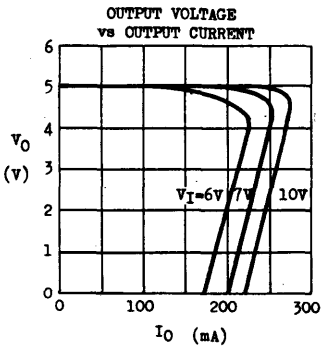
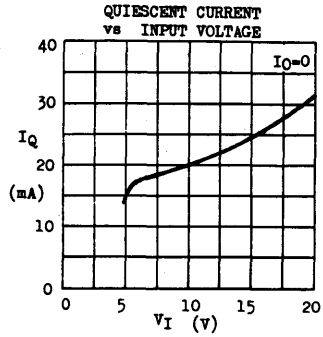
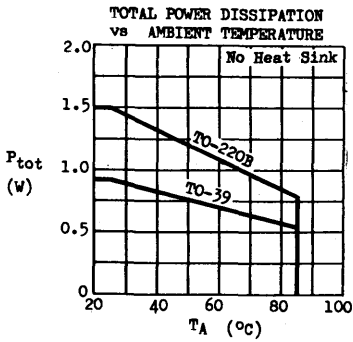

CIRCUIT APPLICATIONS

5V / 200mA OUTPUT

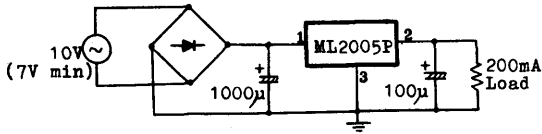

5.8V / 200mA OUTPUT

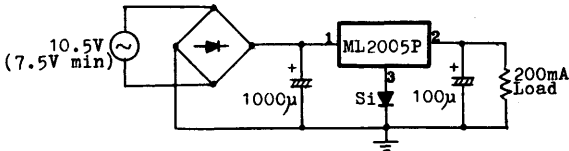

5V / 1A OUTPUT

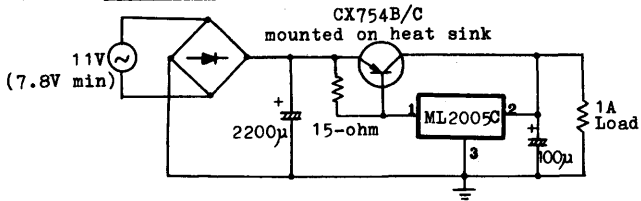

5V / 2A OUTPUT

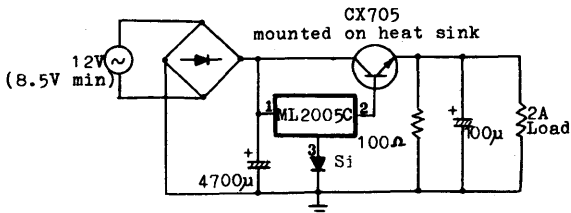

ML9400

VOLTAGE-TO-FREQUENCY CONVERTER

DESCRIPTION

The ML9400 is a low cost voltage-to-frequency converter combining Bipolar and CMOS technology on a single chip. The converter accepts a variable analog input signal and generates an output pulse train whose frequency is linearly proportional to the input voltage. A complete V to F system requires addition of only 2 capacitors, 3 resistors, and 2 supply voltages. F to V conversion is also possible.

FEATURES

- * 10Hz to 100kHz operation
- * $\pm 0.01\%$ typical linearity to 10kHz
- * $\pm 25\text{PPM}/^\circ\text{C}$ typ. gain temperature stability
- * Open collector output
- * Output can drive 5TTL loads as well as CMOS
- * Pulse and square wave outputs
- * Programmable scale factor
- * Low power dissipation: 27mW typical

APPLICATIONS

- * Precision V/F Converters
- * Precision F/V Converters
- * 13 bit A/D Converters
- * μP data acquisition
- * Ultra long time interval integrator
- * Digital scales
- * Thermostats
- * Digital panel meters
- * Phase locked loops
- * Remote control
- * FSK data transmission
- * Analog data transmission & recording
- * VCO
- * Communications scrambler
- * Sound in Video Games

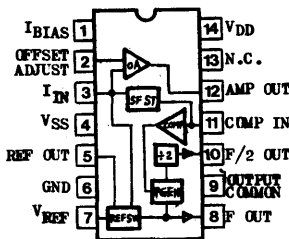

14-Pin Plastic DIP

ABSOLUTE MAXIMUM RATINGS

VDD to VSS	18V
IIN	$\pm 10\text{mA}$
IREF	$\pm 10\text{mA}$
V _{Omax} - V _{O COM}	18V
VREF - VSS	1.5V
Operating temp.	0°C-70°C

VOLTAGE TO FREQUENCY CONVERSION

TYPICAL ELECTRICAL CHARACTERISTICS

Unless otherwise specified, $V_{DD} = 5V$, $V_{SS} = -5V$, $V_{REF} = -6.2V$, $R_{BIAS} = 100K\Omega$, $T_A = 25^\circ C$

INPUT CIRCUIT	I_{in} : 10pA	• $V_{in} = 10V$, $R_{in} = 1M\Omega$
	$V_{io}(\text{offset})$: $< \pm 10mV$	• $0^\circ C < T_A < 70^\circ C$
	$V_{io}(\text{drift})$: $< \pm 5PPM/^\circ C$	• $0^\circ C < T_A < 70^\circ C$
SUPPLY REQUIREMENTS	I_{DD} : 2mA	
	I_{SS} : -1.5mA	
OUTPUTS	VOL : 0.4V	• $I_O = 10mA$
CONVERSION ACCURACY	Linearity(10kHz): $\pm 0.01\%$	• $V_{in} = 0$ to 10V
	(100kHz): $\pm 0.1\%$	• $V_{in} = 0$ to 10V
	Full Scale Temperature Stability : $\pm 25PPM/^\circ C$	• $0^\circ C < T_A < 70^\circ C$

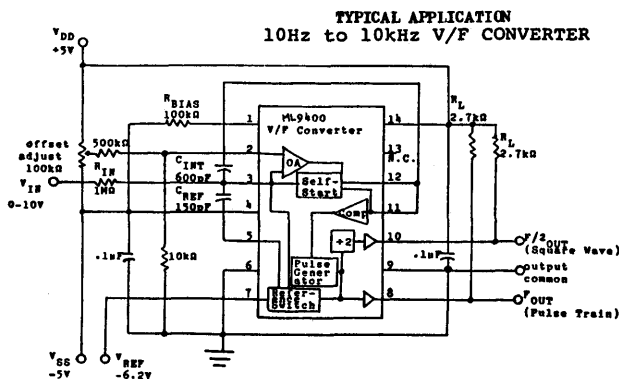

EQUATIONS

$$f_{OUT} = \frac{V_{in}}{(R_{in})} \times \frac{1}{(V_{REF}) (C_{REF})}$$

$$R_{in} = \frac{V_{in} (MAX)}{10\mu A}$$

$$82K \leq R_{BIAS} \leq 120K$$

$$3C_{REF} < C_{INT} < 5C_{REF}$$

For optimum stability:

$$C_{INT} \approx 4 \times C_{REF}$$

NOTES

- To adjust f_{min} , set $V_{in} = 10mV$ and adjust the 100K offset for 10Hz out.
- To adjust f_{max} , set $V_{in} = 10V$ and adjust R_{in} or V_{REF} for 10kHz out.
- Output waveforms :

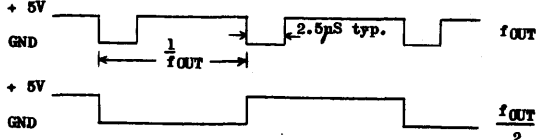

- To increase $f_{OUT(MAX)}$ to 100kHz change C_{REF} to 20pF and C_{INT} to 80pF.
- For high performance applications use high stability components for R_{in} , C_{REF} , and V_{REF} . (metal film resistors and glass film capacitors.) Also separate the output ground (Pin 9) from the input ground (Pin 6).

FREQUENCY TO VOLTAGE CONVERSION

INPUT	Frequency ²	: 10Hz to 100kHz
	Voltage ¹	: min -0.2V, +0.2V max -2V, +VDD
	Waveform	: Sine, Triangular, Square, or Pulse
	Duty Cycle	: 0.5 μ S min negative pulse width 5.0 μ S min positive pulse width
	Impedance	: > 10M Ω (FET INPUT)
OUTPUT	VOUT Range	: 0 to 4V (VDD ⁻¹)
	VOUT	: = [VREF X CREF X RINT] FIN
	Response Time	: RINT x CINT
	Ripple	: Inversely proportional to CINT and input frequency
	Loading	: 2K Ω min
ACCURACY	Better than 0.1% FS	

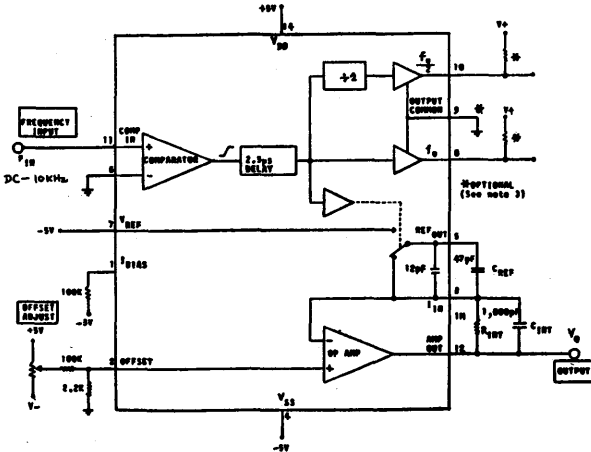

DC -10kHz F/V CONVERTER

NOTES

- The input signal must cross through zero in order to trip the comparator. In order to overcome the hysteresis the amplitude must be greater than $\pm 100\text{mV}$. If the comparator input voltage exceeds -2.5V then the Op Amp output will go to its maximum positive output voltage for the duration of the overvoltage.

If the input voltage has a wide amplitude variation then a pair of back to back diodes may be used to limit the voltage to $\pm 0.7\text{V}$.

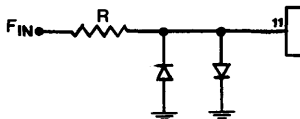

If only a unipolar input signal (F_{IN}) is available it is recommended that either an offset circuit using resistor be used or that the signal be coupled in via a capacitor.

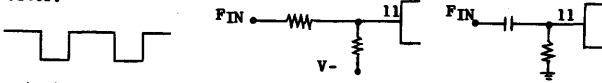

The output voltage of the Op Amp is referenced to Pin 6 (GND). So if Pin 6 is used to determine the comparator threshold the Op Amp output reference will also be shifted.

2. For 100KHz maximum input R_{INT} should be decreased to 100K Ω .
3. f_o and $f_o/2$ are not used in the F/V mode. However, these outputs may be useful for some applications, such as a buffer to feed additional circuitry. f_o will then follow the input frequency waveform; except that f_o will go high 3 μ S after F_{IN} goes high. $f_o/2$ will be square wave with a frequency of one half f_o .

If these outputs are not used then Pins 8, 9, and 10 may be left floating or connected to ground.

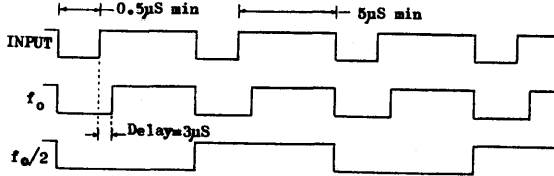

SINGLE SUPPLY F/V

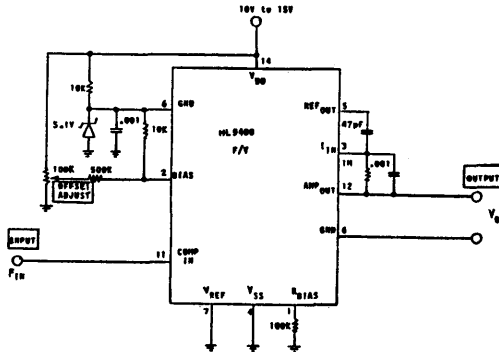

NOTES :

1. The input is now referenced to 5.1V (Pin 6). The input signal must therefore be restricted to be greater than 3 volts (Pin 6 -2V) and less than 10 to 15V (V_{DD}). If the signal is AC coupled then a resistor (100K to 10M Ω) must be placed between the input (Pin 11) and Pin 6.
2. The output will now be referenced to Pin 6 which is at 5.1V (V_Z). For frequency meter applications a 1M Ω meter with a series scaling resistor can be placed across Pins 6 and 12.

MPS3638 and similar types

SILICON GENERAL PURPOSE AMPLIFIERS AND SWITCHES

THE FOLLOWING TRANSISTORS ARE SILICON PLANAR EPITAXIAL TRANSISTORS FOR USE IN GENERAL PURPOSE AMPLIFIERS AND MEDIUM SPEED SWITCHING UP TO 500mA COLLECTOR CURRENT. THEIR MAXIMUM POWER DISSIPATION=500mW @ $T_A < 25^\circ\text{C}$.

CASE TO-92A



D.C. CHARACTERISTICS ($T_A=25^\circ\text{C}$) For p-n-p devices, voltage and current values are negative

TYPE	POLARITY	V_{VCBO} (V)	V_{VCE0} (V)	V_{VEBO} (V)	$I_{CES} \bullet V_{CE}$ (mA) (V)	$h_{FE} \bullet I_C/V_{CE}$ (mA)(V)	$V_{CE(sat)} \& V_{BE(sat)} \bullet I_C/I_B$ (V) (V)	I_C/I_B (mA)(mA)
		min	min	min	max	min-max	max	min-max
MPS3638	FNP	25	25	4	35 @ 15	20- @ 10/10 30- @ 50/1 20- @ 300/2	0.25 1.0	-1.1 @ 50/2.5 0.8-2.0 @ 300/30
MPS3638A	FNP	25	25	4	35 @ 15	80- @ 1/10 100- @ 10/10 100- @ 50/1 20- @ 300/2	0.25 1.0	-1.1 @ 50/2.5 0.8-2.0 @ 300/30
FN3641	NPN	60	30	5	50 @ 50	40-120 @ 150/10	0.22	@ 150/15
FN3642	NPN	60	45	5		15- @ 500/10		
FN3643	NPN	60	30	5		100-300 @ 150/10 25- @ 500/10		
FN3644	FNP	45	45	5	35 @ 30	40- @ 0.1/10 80- @ 1/10 100- @ 10/10	0.25 0.4	-1.0 @ 50/2.5 -1.3 @ 150/15
FN3645	FNP	60	60	5	35 @ 50	80-240 @ 50/1 100-300 @ 150/10 20- @ 300/2	1.0	0.8-2.0 @ 300/30
FN5128	NPN	15	12	3	50 @ 10	20- @ 10/10 35-350 @ 50/10	0.25	-1.1 @ 150/15
FN5142	FNP	20	20	4	50 @ 12	30- @ 50/1 15- @ 300/10	0.5 2.0	-1.5 @ 50/2.5 0.8-2.5 @ 300/30

MPS3638 and similar types

A.C. CHARACTERISTICS ($T_A=25^\circ\text{C}$)

For p-p device, voltage and current values are negative.

TYPE	$f_T @ I_C/V_{CE}$ (MHz)(mA)(V)	$C_{ob} @ V_{CB}=10V$ $I_E=0$ (pF)	$C_{ib} @ V_{EB}=0.5V$ $I_C=0$ (pF)	t_{on} (nS)	t_{off} (nS)	NOTE
	min	max	max	max	max	
MPS3638	100 @ 50/3	20	65	75	170	$t_{on} @ I_C=300mA$ $I_{B1}=30mA$ $t_{off} @ I_C=300mA$ $I_{B1}=30mA$ $-I_{B2}=30mA$
MPS3638A	150 @ 50/3	10	25			
FN3641	150 @ 50/5	8				
FN3642	150 @ 50/5					
FN3643	250 @ 50/5					
FN3644	200 @ 20/20	8	25	40	100	
FN3645						
FN5128	150 @ 50/5	10	30	100	200	
FN5142	100 @ 50/3					

TYPICAL CHARACTERISTICS

($T_A=25^\circ\text{C}$ unless otherwise noted)

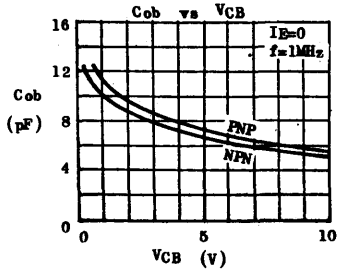
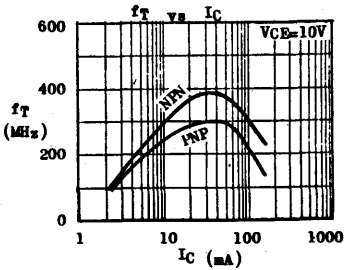
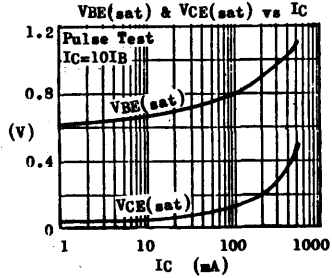
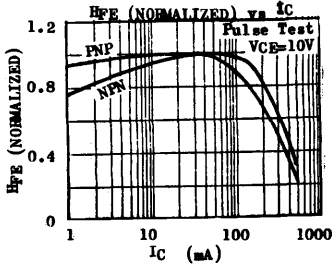

MPS4354, 5, 6 PN3567, 8, 9

COMPLEMENTARY SILICON AF MEDIUM POWER AMPLIFIERS & SWITCHES

THE MPS4354, 5, 6 (PNP) AND PN3567, 8, 9 (NPN)
ARE COMPLEMENTARY SILICON PLANAR EPITAXIAL
TRANSISTORS DESIGNED FOR AF MEDIUM POWER AMPLIFIERS
AND MEDIUM SPEED SWITCHING APPLICATIONS.

CASE T0-92A



EBC

ABSOLUTE MAXIMUM RATINGS

For p-n-p devices, voltage and current values are negative

		PNP		NPN	
		MPS4354	MPS4356	PN3567	PN3568
Collector-Base Voltage	VCBO	60V	80V	80V	80V
Collector-Emitter Voltage	VCEO	60V	80V	40V	60V
Emitter-Base Voltage	VEBO	5V	5V	5V	5V
Collector Current	IC	1A			
Total Power Dissipation (TA < 25°C)	Ptot	625mW			
		derate 5mW/°C above 25°C			
		1.5W			
		derate 12mW/°C above 25°C			
Operating Junction & Storage Temperature	Tj, Tstg	-55 to 150°C			

ELECTRICAL CHARACTERISTICS (TA=25°C unless otherwise noted)

PARAMETER	SYMBOL	MPS TYPES		PN TYPES		UNIT	TEST CONDITIONS	
		MIN	MAX	MIN	MAX			
Collector-Base Breakdown Voltage	VCBO	↑		↑		V	IC=0.01mA IB=0	
Collector-Emitter Breakdown Voltage	VCEO*	Note 1		Note 1		V	IC=10mA IB=0	
Emitter-Base Breakdown Voltage	VEBO	↓		↓		V	IE=0.01mA IC=0	
Collector Cutoff Current	ICBO		50			nA	VCB=50V IB=0	
			5			μA	VCB=50V IB=0	
						50	nA	VCB=40V IB=0
						5	μA	VCB=40V IB=0
							TA=75°C	
Emitter Cutoff Current	IEBO	100		25		nA	VEB=4V IC=0	
Collector-Emitter Saturation Voltage	VCE(sat)*	0.15		0.25		V	IC=150mA IB=15mA	
		0.5				V	IC=500mA IB=50mA	
		1				V	IC=1A IB=0.1A (Note 2)	
Base-Emitter Saturation Voltage	VBE(sat)*	0.9				V	IC=150mA IB=15mA	
		1.1				V	IC=500mA IB=50mA	
		1.2				V	IC=1A IB=0.1A (Note 2)	

* Pulse Test : Pulse Width=0.3mS, Duty Cycle=1%

Note 1 : equal to the values of absolute maximum ratings. Note 2 : for MPS4355 only

MPS4354, 5, 6 PN3567, 8, 9

PARAMETER	SYMBOL	MPS TYPES		FN TYPES		UNIT	TEST CONDITIONS
		MIN	MAX	MIN	MAX		
Base-Emitter Voltage	$V_{BE} *$			1.1		V	$I_C=150mA$ $V_{CE}=1V$ $I_C=500mA$ $V_{CE}=0.5V$ $I_C=1A$ $V_{CE}=1V$ (Note 2)
				1.1		V	
				1.2		V	
Current Gain-Bandwidth Product	f_T	100	500	60	600	MHz	$I_C=50mA$ $V_{CE}=10V$
Collector-Base Capacitance	C_{cb}		30		20	pF	$V_{CB}=10V$ $I_B=0$ $f=140kHz$
Emitter-Base Capacitance	C_{eb}		110		80	pF	$V_{EB}=0.5V$ $I_C=0$ $f=140kHz$
Noise Figure	NF		3			dB	$I_C=0.1mA$ $V_{CE}=10V$ $R_g=1k\Omega$ $f=1kHz$
Turn-On Time	t_{on}		100			nS	$V_{cc}=30V$ $I_C=500mA$ $I_{B1}=50mA$
Turn-Off Time	t_{off}		400			nS	$V_{cc}=30V$ $I_C=500mA$ $I_{B1}=-I_{B2}=50mA$

D.C. CURRENT GAIN— H_{FE} AT $T_A=25^\circ C *$

● I_C/V_{CE}	MPS4354		MPS4355		MPS4356		FN3567		FN3568		FN3569	
	MIN	MAX	MIN	MAX	MIN	MAX	MIN	MAX	MIN	MAX	MIN	MAX
0.1mA/10V	25		60		25							
1mA/10V	40		75		40							
10mA/10V	50	500	100	400	50	250						
100mA/10V	40		75		40							
500mA/10V	30		75		30							
30mA/1V							40		40		100	
150mA/1V							40	120	40	120	100	300

* Pulse Test : Pulse Width=0.3ms, Duty Cycle=1%

Note 2 : for MPS4355 only.

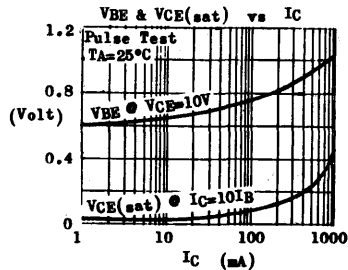
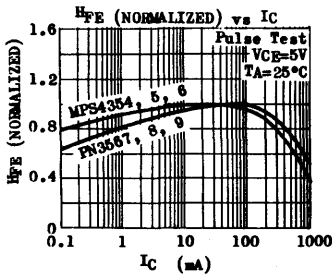

3.78.0810B.8100A/B

MPS6530 through MPS6535

COMPLEMENTARY

SILICON GENERAL PURPOSE AMPLIFIERS & SWITCHES

THE MPS6530 THROUGH MPS6535 ARE SILICON PLANAR EPITAXIAL TRANSISTORS FOR GENERAL PURPOSE AMPLIFIERS AND MEDIUM SPEED SWITCHING APPLICATIONS UP TO 600mA COLLECTOR CURRENT. THE MPS6530, MPS6531, MPS6532 ARE NPN AND ARE COMPLEMENTARY TO THE PNP MPS6533, MPS6534, MPS6535 RESPECTIVELY.

CASE TO-92A



ABSOLUTE MAXIMUM RATINGS

For p-n-p devices, voltage and current values are negative

		NPN		PNP	
		MPS6530 MPS6531	MPS6532	MPS6533 MPS6534	MPS6535
Collector-Base Voltage	V _{CBO}	60V	50V	40V	30V
Collector-Emitter Voltage	V _{CEO}	40V	30V	40V	30V
Emitter-Base Voltage	V _{EB0}	5V	5V	4V	4V
Collector Current	I _C			0.6A	
Total Power Dissipation (T _C ≤ 25°C)	P _{tot}			1.2W	
	(T _A ≤ 25°C)			500mW	
Operating Junction & Storage Temperature	T _j , T _{stg}			-55 to 150°C	

ELECTRICAL CHARACTERISTICS (T_A = 25°C unless otherwise noted)

PARAMETER	SYMBOL	MIN	TYP	MAX	UNIT	TEST CONDITIONS
Collector-Base Breakdown Voltage MPS6530, MPS6531 MPS6532 MPS6533, MPS6534 MPS6535	BV _{CBO}	60			V	I _C = 0.01mA I _E = 0
Collector-Emitter Breakdown Voltage MPS6530, MPS6531 MPS6532 MPS6533, MPS6534 MPS6535	LV _{CEO} *	40			V	I _C = 10mA I _B = 0
Emitter-Base Breakdown Voltage MPS6530, 1, 2 MPS6533, 4, 5	BV _{EB0}	5			V	I _E = 0.01mA I _C = 0
Collector Cutoff Current MPS6530, MPS6531 MPS6532 MPS6533, MPS6534 MPS6535	ICBO			50	nA	V _{CB} = 40V I _E = 0
				100	nA	V _{CB} = 30V I _E = 0
				50	nA	V _{CB} = 30V I _E = 0
				100	nA	V _{CB} = 20V I _E = 0

MPS6530 through MPS6535

PARAMETER	SYMBOL	MIN	TYP	MAX	UNIT	TEST CONDITIONS
Collector Cutoff Current MPS6530, MPS6531 MPS6532 MPS6533, MPS6534 MPS6535	I _{CBO}			2 5 2 5	μA μA μA μA	V _{CB} =40V I _E =0 T _A =60°C V _{CB} =30V I _E =0 T _A =60°C V _{CB} =30V I _E =0 T _A =60°C V _{CB} =20V I _E =0 T _A =60°C
Collector-Emitter Saturation Voltage MPS6530, MPS6532 MPS6531 MPS6533, MPS6535 MPS6534	V _{CE(sat)} *		0.5 0.3 0.5 0.3		V V V V	I _C =100mA I _B =10mA
Base-Emitter Saturation Voltage MPS6530, MPS6531 MPS6532 MPS6533, MPS6534 MPS6535	V _{BE(sat)} *		1.0 1.2 1.0 1.2		V V V V	I _C =100mA I _B =10mA
D.C. Current Gain MPS6530, MPS6533	h _{FE} *	30 40 25	120			I _C =10mA V _{CE} =1V I _C =100mA V _{CE} =1V I _C =500mA V _{CE} =10V
D.C. Current Gain MPS6531, MPS6534	h _{FE} *	60 90 50	270			I _C =10mA V _{CE} =1V I _C =100mA V _{CE} =1V I _C =500mA V _{CE} =10V
D.C. Current Gain MPS6532, MPS6535	h _{FE} *	30				I _C =100mA V _{CE} =1V
Collector-Base Capacitance MPS6530, 1, 2 MPS6533, 4, 5	C _{ob}	3.8 4.8	5 6		pF pF	V _{CB} =10V I _B =0 f=100kHz
Current Gain-Bandwidth Product	f _T	250			MHz	I _C =50mA V _{CE} =10V

* Pulse Test ; Pulse Width=0.3mS, Duty Cycle=1%

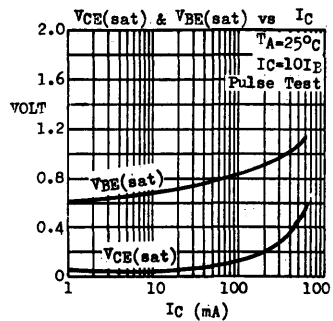
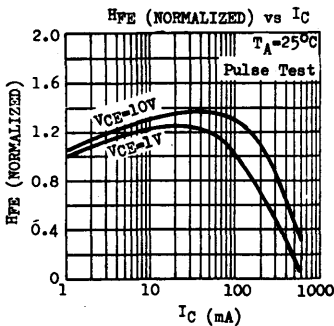

MPS6560 MPS6561 MPS6562 MPS6563

COMPLEMENTARY SILICON AF MEDIUM POWER TRANSISTORS

THE MPS6560, MPS6561 (NPN) AND MPS6562, MPS6563 (PNP) ARE SILICON PLANAR EPITAXIAL TRANSISTORS DESIGNED FOR COMPLEMENTARY SYMMETRY AUDIO OUTPUT APPLICATIONS. THEY FEATURE LOW COLLECTOR TO EMITTER SATURATION VOLTAGE (0.23V TYPICAL @ $I_C=500mA$).

CASE TO-92A



ERC

ABSOLUTE MAXIMUM RATINGS

For p-n-p devices, voltage and current values are negative

		MPS6560 (NPN) MPS6562 (PNP)	MPS6561 (NPN) MPS6563 (PNP)
Collector-Base Voltage	V_{CB0}	25V	20V
Collector-Emitter Voltage	V_{CE0}	25V	20V
Emitter-Base Voltage	V_{EB0}		5V
Collector Current	I_C	0.6A	
Total Power Dissipation ($T_C \leq 25^\circ C$)	P_{tot}	1.5W	
	($T_A \leq 25^\circ C$)		625mW
Operating Junction & Storage Temperature	T_j, T_{stg}	-55 to 150°C	

ELECTRICAL CHARACTERISTICS ($T_A=25^\circ C$ unless otherwise noted)

PARAMETER	SYMBOL	MPS6560 (NPN)		MPS6561 (NPN)		UNIT	TEST CONDITIONS
		MIN	MAX	MIN	MAX		
Collector-Base Breakdown Voltage	BV_{CB0}	25		20		V	$I_C=0.1mA$ $I_E=0$
Collector Cutoff Current	I_{CBO}		100		100	nA	$V_{CB}=20V$ $I_E=0$
Collector Cutoff Current	I_{CEO}		100		100	nA	$V_{CE}=V_{CE0}$ $I_B=0$
Emitter Cutoff Current	I_{EBO}		100		100	nA	$V_{EB}=4V$ $I_C=0$
Collector-Emitter Saturation Voltage	$V_{CE(sat)}$ *		0.5		0.5	V	$I_C=500mA$ $I_B=50mA$ $I_C=350mA$ $I_B=35mA$
Base-Emitter Voltage	V_{BE} *		1.2		1.2	V	$I_C=500mA$ $V_{CE}=1V$ $I_C=350mA$ $V_{CE}=1V$
D.C. Current Gain	h_{FE} *	35		35			$I_C=10mA$ $V_{CE}=1V$ $I_C=100mA$ $V_{CE}=1V$ $I_C=500mA$ $V_{CE}=1V$ $I_C=350mA$ $V_{CE}=1V$
Current Gain-Bandwidth Product	f_T	60		60		MHz	$I_C=10mA$ $V_{CE}=10V$
Collector-Base Capacitance	C_{ob}		30		30	pF	$V_{CB}=10V$ $I_E=0$ $f=100kHz$

* Pulse Test : Pulse Width=0.5ms, Duty Cycle=1%

MPS6560 MPS6561 MPS6562 MPS6563

TYPICAL CHARACTERISTICS

($T_A=25^\circ\text{C}$ unless otherwise noted)

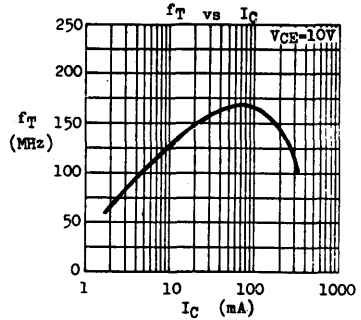
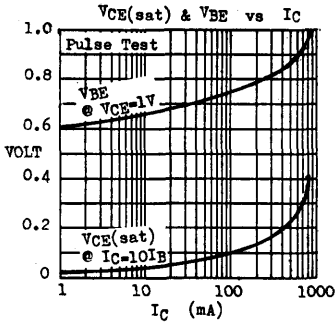
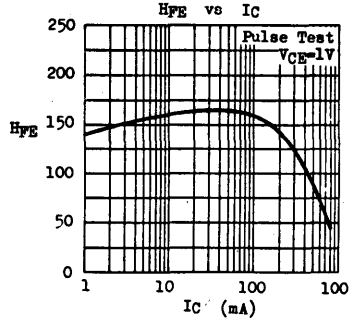
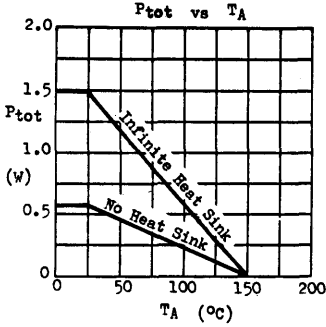

MPS6565 and similar types

NPN SILICON AF SMALL SIGNAL TRANSISTORS

THE ABOVE TYPES ARE NPN SILICON PLANAR EPITAXIAL TRANSISTORS FOR USE IN AF SMALL SIGNAL AMPLIFIERS AND DIRECT COUPLED CIRCUITS. THEIR MAXIMUM POWER DISSIPATION = 360mW AT $T_A \leq 25^\circ\text{C}$.

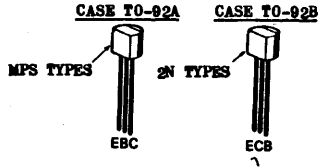

DEVICE SPECIFICATIONS ($T_A=25^\circ\text{C}$)

DEVICE TYPE	V_{CE0} (V)	V_{VE0} (V)	$I_{C0} \bullet V_{CB}$ (mA) (V)	$R_{FE} \bullet I_C/V_{CE}$ (mA)(V)	$V_{CE(sat)} \bullet I_C/I_B$ (V) (mA)(mA)	N_{0FE}
	min	min	max	min-max	max	
MPS/2N2711	18	5	500 \bullet 18	30-90 \bullet 2/4.5		$C_{ob} < 4pF \bullet V_{CB}=10V$
MPS/2N2712	18	5	500 \bullet 18	75-225 \bullet 2/4.5		$C_{ob} < 12pF \bullet V_{CB}=10V$
MPS/2N2716	18	5	500 \bullet 18	75-225 \bullet 2/4.5		$C_{ob} < 5pF \bullet V_{CB}=10V$
MPS/2N2923	25	5	500 \bullet 25	90-180 \bullet 2/10		* $h_{fe} \bullet 1KHz$
MPS/2N2924				150-300 \bullet 2/10		
MPS/2N2925				235-470 \bullet 2/10		
MPS/2N3390	25	5	100 \bullet 18	400-800 \bullet 2/4.5		
MPS/2N3391				250-500 \bullet 2/4.5		
MPS/2N3392				150-300 \bullet 2/4.5		
MPS/2N3393				90-180 \bullet 2/4.5		
MPS/2N3394				55-110 \bullet 2/4.5		
MPS/2N3395				150-500 \bullet 2/4.5		
MPS/2N3396				90-500 \bullet 2/4.5		
MPS/2N3397				55-500 \bullet 2/4.5		
MPS/2N3398				55-800 \bullet 2/4.5		
MPS/2N3707	30	6	100 \bullet 20	100-400 \bullet 0.1/5	1.0 \bullet 10/0.5	For MPS/2N3707 only $N_F < 5dB \bullet$ $I_C=0.1mA \bullet V_{CB}=5V$ $R_p=10KA \bullet f=30-15K Hz$
MPS/2N3708				45-660 \bullet 1/5		
MPS/2N3709				45-165 \bullet 1/5		
MPS/2N3710				90-330 \bullet 1/5		
MPS/2N3711				180-660 \bullet 1/5		
MPS/2N5172	25	5	100 \bullet 25	100-500 \bullet 10/10	0.25 \bullet 10/1	
MPS 6512	30	4	50 \bullet 30	50-100 \bullet 2/10	0.5 \bullet 50/5	$C_{ob} < 3.5pF \bullet V_{CB}=10V$
MPS 6513				30- \bullet 100/10		
MPS 6565	45	4	100 \bullet 30	40-180 \bullet 10/10	0.4 \bullet 10/1	$C_{ob} < 3.5pF \bullet V_{CB}=10V$ $f_T > 200MHz \bullet I_C=10mA$ $V_{CB}=10V$
MPS 6566				100-400 \bullet 10/10		
MPS 6573	35	4	100 \bullet 35	100- \bullet 0.1/5	0.5 \bullet 10/1	* H_{FE} GROUPINGS : Y = 100-150 B = 125-185 G = 160-225 S = 200-300
MPS 6574	35	4	100 \bullet 35	200-500 \bullet 10/5	0.5 \bullet 10/1	
MPS 6575	45	4	100 \bullet 45	100- \bullet 0.1/5	0.5 \bullet 10/1	
MPS 6576	45	4	100 \bullet 45	200-500 \bullet 10/5	0.5 \bullet 10/1	

MPS6565 and similar types

TYPICAL CHARACTERISTICS ($T_A=25^\circ\text{C}$ UNLESS OTHERWISE SPECIFIED)

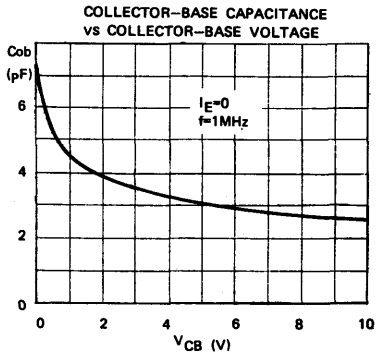
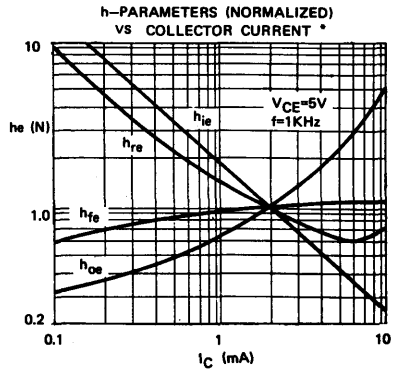
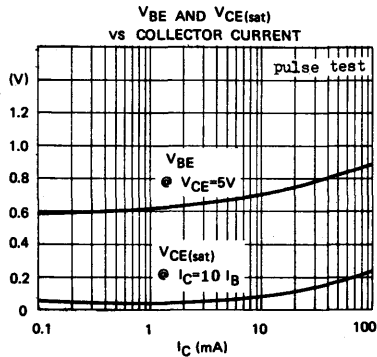
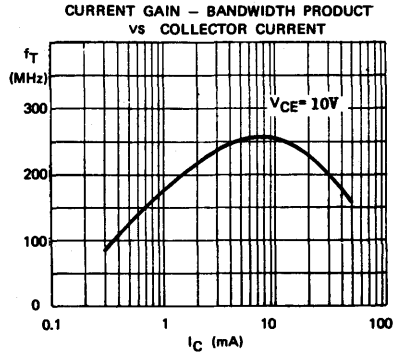
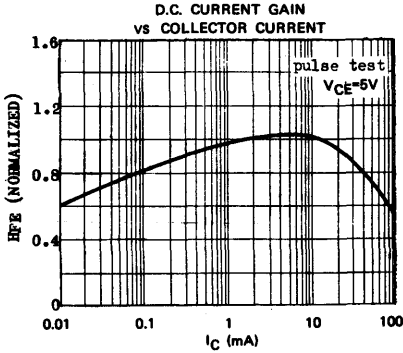

*Typical values at $I_C=2mA$ $V_{CE}=5V$		
H_{FE} (D.C.)	300	500
h_{ie} (1KHz)	4.5Kohms	8.7Kohms
h_{fe} (1KHz)	330	600
h_{re} (1KHz)	2×10^{-4}	3×10^{-4}
h_{oe} (1KHz)	30 μ mhos	60 μ mhos

3.78.4300B/A

MPS8000

NPN RF MEDIUM POWER AMPLIFIER & DRIVER

THE MPS8000 IS AN NPN SILICON PLANAR EPITAXIAL TRANSISTOR DESIGNED FOR RF DRIVER AND LOW POWER OUTPUT STAGE IN CB EQUIPMENT OPERATING TO 30MHz.

CASE TO-92A



X-67 HEAT SINK

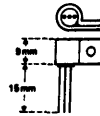

ABSOLUTE MAXIMUM RATINGS

Collector-Emitter Voltage ($V_{BE}=0$)	V_{CES}	60V
Collector-Emitter Voltage ($I_B=0$)	V_{CEO}	30V
Emitter-Base Voltage	V_{EBO}	3V
Collector Current	I_C	0.5A
Collector Peak Current	I_{CM}	1A
Total Power Dissipation @ $T_C \leq 25^\circ C$	P_{tot}	1.5W
With X-67 Heat Sink @ $T_A \leq 25^\circ C$		800mW
No Heat Sink @ $T_A \leq 25^\circ C$		625mW
Operating Junction & Storage Temperature	T_j, T_{stg}	-55 to 150°C

ELECTRICAL CHARACTERISTICS ($T_A=25^\circ C$ unless otherwise noted)

PARAMETER	SYMBOL	MIN	TYP	MAX	UNIT	TEST CONDITIONS
Collector-Emitter Breakdown Voltage	V_{CES}	60			V	$I_C=50mA$ (Pulsed) $V_{BE}=0$
Emitter-Base Breakdown Voltage	V_{EBO}	3	6		V	$I_E=1mA$ $I_C=0$
Collector Cutoff Current	I_{CBO}			10	μA	$V_{CB}=50V$ $I_E=0$
Collector-Emitter Saturation Voltage	$V_{CE(sat)}$	0.07	0.3		V	$I_C=100mA$ $I_B=10mA$
Base-Emitter Saturation Voltage	$V_{BE(sat)}$	0.72			V	$I_C=100mA$ $I_B=10mA$
D.C. Current Gain	β_{FE}	30	150			$I_C=100mA$ $V_{CE}=2V$
Current Gain-Bandwidth Product	f_T	150	240		MHz	$I_C=50mA$ $V_{CE}=10V$
Power Output	P_{out}	350			mW	$V_{CC}=13.6V$ $f=27MHz$ $P_{in}=21.8mW$

TYPICAL CHARACTERISTICS AT $T_A=25^\circ\text{C}$

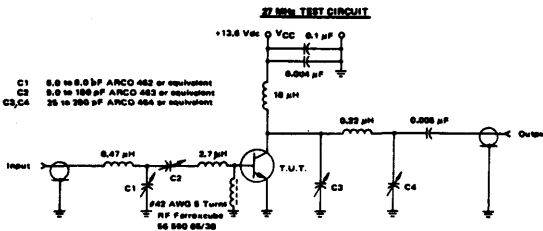
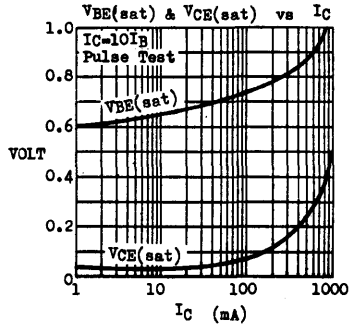
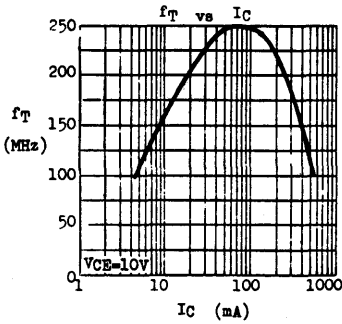
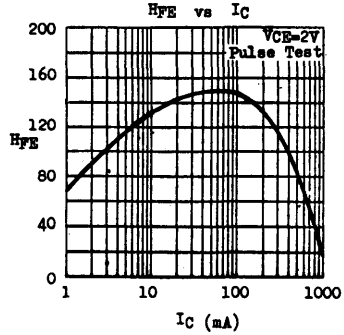
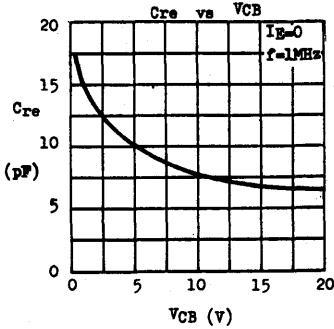

MPS-A05 MPS-A06 MPS-A55 MPS-A56

COMPLEMENTARY SILICON AF MEDIUM POWER TRANSISTORS

THE MPS-A05, MPS-A06, MPS-A55, MPS-A56 ARE SILICON PLANAR EPITAXIAL TRANSISTORS FOR AF DRIVERS AND OUTPUTS, AS WELL AS FOR UNIVERSAL APPLICATIONS. THE MPS-A05, MPS-A06 ARE NPN AND ARE COMPLEMENTARY TO THE PNP MPS-A55 AND MPS-A56 RESPECTIVELY.

CASE TO-92A



ABSOLUTE MAXIMUM RATINGS <small>For p-n-p devices, voltage and current values are negative</small>		MPS-A05(NPN)	MPS-A06(NPN)
		MPS-A55(PNP)	MPS-A56(PNP)
Collector-Base Voltage	V _{CB0}	60V	60V
Collector-Emitter Voltage	V _{CE0}	60V	80V
Emitter-Base Voltage	V _{EB0}		4V
Collector Current	I _C	0.5A	
Collector Peak Current (t ≤ 10ms)	I _{CM}	1.5A	
Total Power Dissipation (T _C ≤ 25°C)	P _{tot}	1.5W	
(T _A ≤ 25°C)		625mW	
Operating Junction & Storage Temperature	T _j , T _{stg}	-55 to 150°C	

ELECTRICAL CHARACTERISTICS (T_A = 25°C unless otherwise noted)

PARAMETER	SYMBOL	MPS-A05(NPN)		MPS-A06(NPN)		UNIT	TEST CONDITIONS
		MPS-A55(PNP)		MPS-A56(PNP)			
		MIN	MAX	MIN	MAX		
Collector-Emitter Breakdown Voltage	V _{CE0} *	60		80		V	I _C =1mA I _B =0
Emitter-Base Breakdown Voltage	V _{EB0}	4		4		V	I _E =0.1mA I _C =0
Collector Cutoff Current	I _{CB0}		100		100	nA	V _{CB} =V _{CE0} I _E =0
Collector-Emitter Saturation Voltage	V _{CE(sat)} *		0.25		0.25	V	I _C =100mA I _B =10mA
Base-Emitter Saturation Voltage	V _{BE} *		1.2		1.2	V	I _C =100mA V _{CE} =1V
D.C. Current Gain	h _{FE} *	50		50			I _C =10mA V _{CE} =1V I _C =100mA V _{CE} =1V
Current Gain-Bandwidth Product	f _T	50		50		MHz	I _C =100mA V _{CE} =1V
		100		100		MHz	I _C =100mA V _{CE} =2V
Collector-Base Capacitance	C _{ob}		20		20	pF	V _{CB} =10V I _E =0 f=1MHz

* Pulse Test ; Pulse Width=0.5ms, Duty Cycle=1%

MPS-A05 MPS-A06 MPS-A55 MPS-A56

TYPICAL CHARACTERISTICS ($T_A=25^\circ\text{C}$ unless otherwise noted)

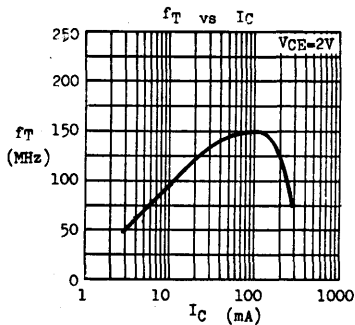
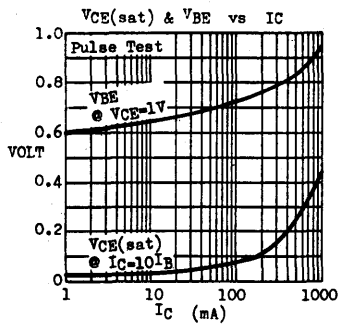
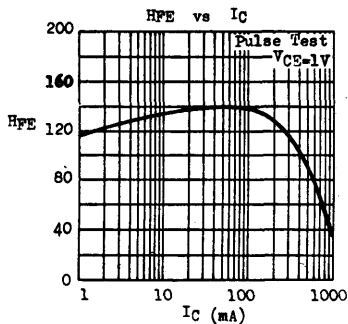
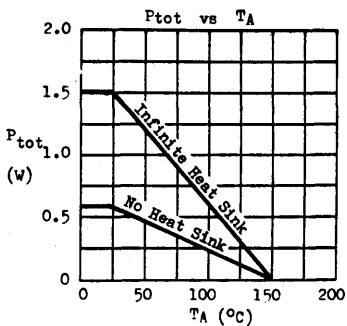

MPS-A13 MPS-A14 MPS-A65 MPS-A66

NPN PNP SILICON DARLINGTON AF MEDIUM POWER TRANSISTORS

THE MPS-A13, MPS-A14 (NPN) AND MPS-A65, MPS-A66 (PNP) ARE SILICON PLANAR EPITAXIAL DARLINGTON TRANSISTORS FOR AF AMPLIFIERS REQUIRING HIGH INPUT IMPEDANCE.

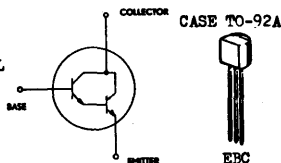

		MPS-A13 (NPN)	MPS-A65 (PNP)
		MPS-A14 (NPN)	MPS-A66 (PNP)
Collector-Emitter Voltage ($V_{BE=0}$)	V_{CES}	30V	30V
Emitter-Base Voltage	V_{EBO}	10V	8V
Collector Current	I_C		0.3A
Total Power Dissipation ($T_C \leq 25^\circ\text{C}$)	P_{tot}		1.2W
($T_A \leq 25^\circ\text{C}$)			0.5W
Operating Junction & Storage Temperature	T_j, T_{stg}		-55 to 150°C

ELECTRICAL CHARACTERISTICS ($T_A=25^\circ\text{C}$ unless otherwise noted)

PARAMETER	SYMBOL	MIN	TYP	MAX	UNIT	TEST CONDITIONS
Collector-Emitter Breakdown Voltage	V_{CES}	30			V	$I_C=0.1\text{mA}$ $I_B=0$
Collector Cutoff Current	I_{CBO}		100		nA	$V_{CB}=30\text{V}$ $I_E=0$
Emitter Cutoff Current	I_{EBO}		100		nA	$V_{EB}=V_{EBO}$ $I_C=0$
Collector-Emitter Saturation Voltage	$V_{CE(sat)}$ *	0.75	1.5		V	$I_C=100\text{mA}$ $I_B=0.1\text{mA}$
Base-Emitter Voltage	V_{BE} *	1.35	2.0		V	$I_C=100\text{mA}$ $V_{CE}=5\text{V}$
D.C. Current Gain	MPS-A13 MPS-A14 MPS-A65 MPS-A66	5			$\times 10^3$	$I_C=10\text{mA}$ $V_{CE}=5\text{V}$
D.C. Current Gain	MPS-A13 MPS-A14 MPS-A65 MPS-A66	10			$\times 10^3$	$I_C=100\text{mA}$ $V_{CE}=5\text{V}$
Current Gain-Bandwidth Product	f_T	125			MHz	$I_C=10\text{mA}$ $V_{CE}=5\text{V}$
Collector-Base Capacitance	C_{ob}		3		pF	$V_{CB}=10\text{V}$ $I_E=0$ $f=100\text{kHz}$
Noise Figure ($f=1\text{kHz}$ $R_G=100\Omega$)	NF		2		dB	$I_C=1\text{mA}$ $V_{CE}=5\text{V}$

* Pulse Test: Pulse Width=0.3ms, Duty Cycle=1%

MPS-A13 MPS-A14 MPS-A65 MPS-A66

TYPICAL CHARACTERISTICS
($T_A=25^\circ\text{C}$ unless otherwise noted)

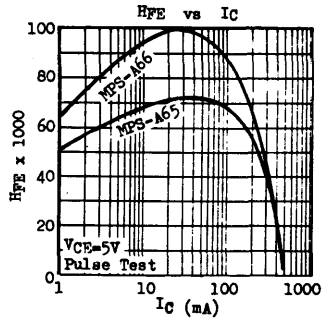
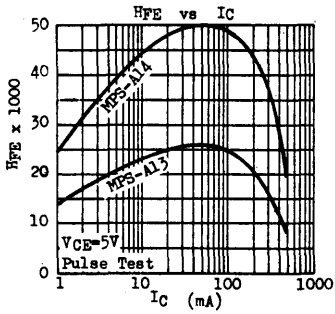
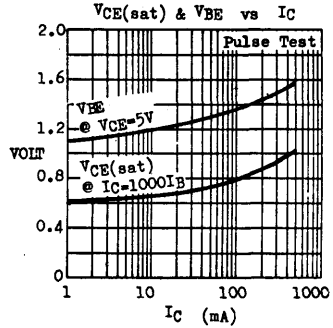
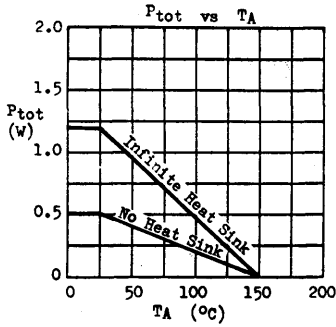

MPS-A20 MPS-A70

COMPLEMENTARY SILICON AF SMALL SIGNAL TRANSISTORS

THE MPS-A20 (NPN) AND MPS-A70 (PNP) ARE SILICON PLANAR EPITAXIAL TRANSISTORS FOR USE IN AF SMALL SIGNAL APPLICATIONS. THEY ARE SUPPLIED IN SELECTED HFE GROUPS.

CASE TO-92A



EBC

ABSOLUTE MAXIMUM RATINGS For p-n-p devices, voltage and current values are negative

MPS-A20 (NPN)
MPS-A70 (PNP)

Collector-Base Voltage	V _{CB0}	45V
Collector-Emitter Voltage	V _{CE0}	40V
Emitter-Base Voltage	V _{EB0}	4V
Collector Current	I _C	100mA
Total Power Dissipation (T _A ≤25°C)	P _{tot}	350mW
		derate 2.8mW/°C above 25°C
Operating Junction & Storage Temperature	T _j , T _{stg}	-55 to 150°C

ELECTRICAL CHARACTERISTICS (T_A=25°C unless otherwise noted)

PARAMETER	SYMBOL	MIN	TYP	MAX	UNIT	TEST CONDITIONS
Collector-Base Breakdown Voltage	BV _{CB0}	45			V	I _C =0.1mA I _B =0
Collector-Emitter Breakdown Voltage	LV _{CE0} *	40			V	I _C =1mA I _B =0
Emitter-Base Breakdown Voltage	BV _{EB0}	4			V	I _C =0.1mA I _C =0
Collector Cutoff Current	I _{CB0}			100	nA	V _{CB} =30V I _B =0
Collector-Emitter Saturation Voltage	V _{CE(sat)} *		0.08	0.25	V	I _C =10mA I _B =1mA
			0.25		V	I _C =100mA I _B =10mA
Base-Emitter Voltage	V _{BE} *		0.67		V	I _C =5mA V _{CE} =10V
D.C. Current Gain	H _{FE} *	40		400		I _C =5mA V _{CE} =10V
	GROUP R	40	70	100		
	GROUP W	80	140	200		
	GROUP B	120	200	300		
	GROUP Y	150	270	400		
Current Gain-Bandwidth Product	f _T	125	200		MHz	I _C =5mA V _{CE} =10V
Collector-Base Capacitance	C _{ob}		2.7	4	pF	V _{CB} =10V I _B =0 f=1MHz
Noise Figure	N _F		2		dB	I _C =0.1mA V _{CE} =10V R _G =10KΩ f=30Hz-15KHz

* Pulse Test : Pulse Width=0.3μS, Duty Cycle=1%

TYPICAL CHARACTERISTICS ($T_A=25^\circ\text{C}$ unless otherwise noted)

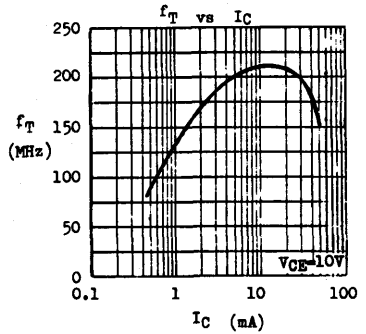
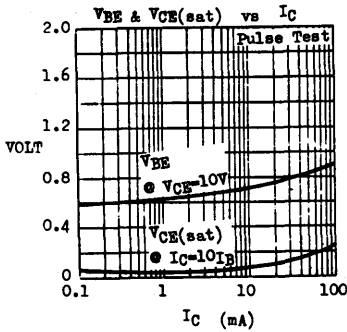
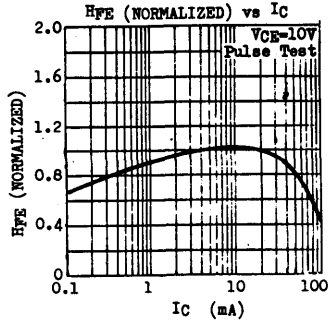
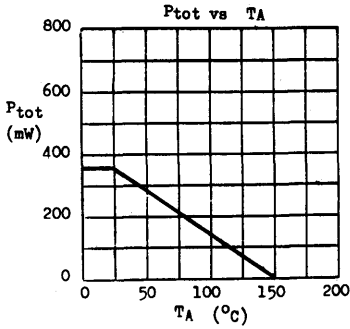

TYPICAL CHARACTERISTICS

($T_A=25^\circ\text{C}$ unless otherwise noted)

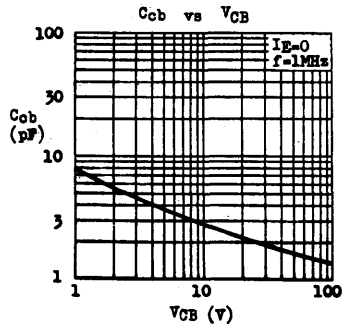
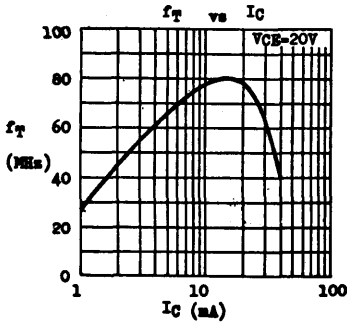
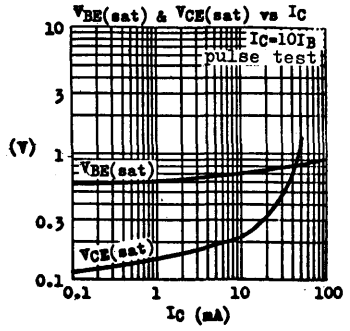
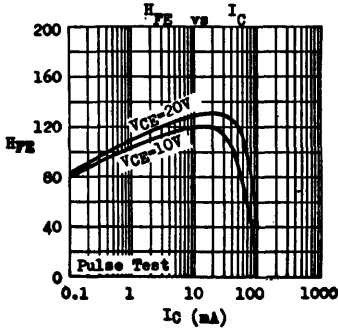

MPS-D01

NPN SILICON GENERAL PURPOSE HIGH VOLTAGE TRANSISTOR

THE MPS-D01 IS NPN SILICON PLANAR TRANSISTOR FOR GENERAL PURPOSE HIGH VOLTAGE AMPLIFIERS AND GAS DISCHARGE DISPLAY DRIVING APPLICATIONS. IT FEATURES 200V MIN COLLECTOR-EMITTER BREAK-DOWN VOLTAGE.

CASE TO-92A



ABSOLUTE MAXIMUM RATINGS

Collector-Base Voltage	V_{CB0}	200V
Collector-Emitter Voltage	V_{CE0}	200V
Emitter-Base Voltage	V_{EB0}	4V
Collector Current	I_C	100mA
Collector Peak Current ($t \leq 10\mu s$)	I_{CM}	500mA
Total Power Dissipation ($T_C \leq 25^\circ C$)	P_{tot}	1.5W
($T_A \leq 25^\circ C$)		625mW
Operating Junction & Storage Temperature	T_j, T_{stg}	-55 to +150°C

ELECTRICAL CHARACTERISTICS ($T_A=25^\circ C$ unless otherwise noted)

PARAMETER	SYMBOL	MIN	TYP	MAX	UNIT	TEST CONDITIONS
Collector-Base Breakdown Voltage	BV_{CB0}	200			V	$I_C=10\mu A$ $I_E=0$
Collector-Emitter Breakdown Voltage	LV_{CE0}	200			V	$I_C=1mA$ $I_B=0$
Emitter-Base Breakdown Voltage	BV_{EB0}	4			V	$I_E=10\mu A$ $I_C=0$
Collector Cutoff Current	I_{CBO}			0.1	μA	$V_{CB}=80V$ $I_E=0$
				4	μA	$V_{CB}=80V$ $I_E=0$ $T_A=75^\circ C$
Collector Cutoff Current	I_{CES}			0.1	μA	$V_{CE}=80V$ $V_{BE}=0$
				4	μA	$V_{CE}=80V$ $V_{BE}=0$ $T_A=75^\circ C$
D.C. Current Gain	h_{FE}	25				$I_C=10mA$ $V_{CE}=10V$
		20				$I_C=30mA$ $V_{CE}=10V$
Current Gain-Bandwidth Product	f_T	40	80		MHz	$I_C=10mA$ $V_{CE}=20V$
Collector-Base Capacitance	C_{ob}			3	pF	$V_{CB}=30V$ $I_E=0$ $f=1MHz$

TYPICAL CHARACTERISTICS

($T_A=25^\circ\text{C}$ unless otherwise noted)

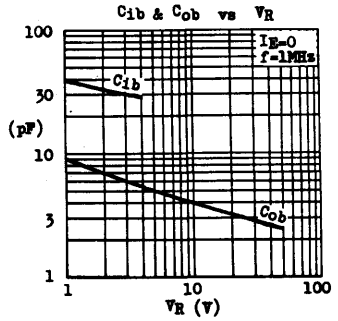
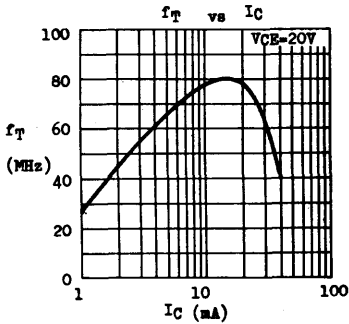
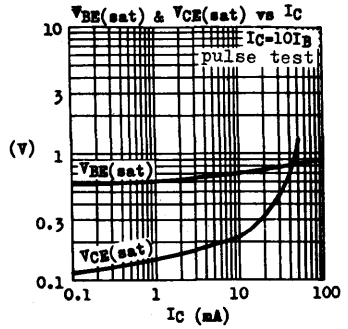
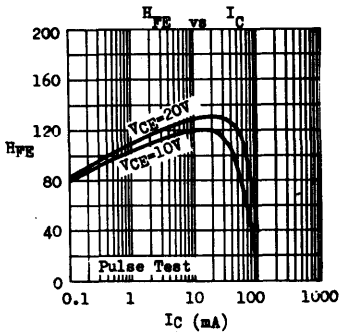

MPS-D05 MPS-D55

COMPLEMENTARY

SILICON GENERAL PURPOSE AMPLIFIERS & SWITCHES

THE MPS-D05 (NPN) AND MPS-D55 (PNP) ARE
 COMPLEMENTARY SILICON PLANAR EPITAXIAL
 TRANSISTORS FOR GENERAL PURPOSE AF AMPLIFIERS
 AND DRIVERS FOR LED DISPLAY.

CASE TO-92A



ABSOLUTE MAXIMUM RATINGS

For pnp device, voltage and current values are negative.

Collector-Base Voltage	V _{CB0}	25V
Collector-Emitter Voltage	V _{CE0}	25V
Emitter-Base Voltage	V _{EB0}	5V
Collector Current	I _C	0.5A
Total Power Dissipation (T _C ≤ 25°C)	P _{tot}	1.2W
(T _A ≤ 25°C)		500mW
Operating Junction & Storage Temperature	T _j , T _{stg}	-55 to 150°C

ELECTRICAL CHARACTERISTICS (T_A = 25°C unless otherwise noted)

PARAMETER	SYMBOL	MIN	TYP	MAX	UNIT	TEST CONDITIONS
Collector-Base Breakdown Voltage	V _{VCBO}	25			V	I _C = 0.01mA I _B = 0
Collector-Emitter Breakdown Voltage	V _{VCED} *	25			V	I _C = 1mA I _B = 0
Emitter-Base Breakdown Voltage	V _{VEBO}	5			V	I _E = 0.01mA I _C = 0
Collector Cutoff Current	I _{CB0}			1	μA	V _{CE} = 20V I _E = 0
Collector Cutoff Current	I _{CE0}			1	μA	V _{CE} = 20V V _{BE} = 0
Emitter Cutoff Current	I _{EB0}			0.1	μA	V _{EB} = 3V I _C = 0
Collector-Emitter Saturation Voltage	V _{CE(sat)} *		0.1	0.5	V	I _C = 100mA I _B = 10mA
Base-Emitter Saturation Voltage	V _{BE(sat)} *		0.85		V	I _C = 100mA I _B = 10mA
D.C. Current Gain	h _{FE} *	50	80	170		I _C = 50mA V _{CE} = 5V I _C = 100mA V _{CE} = 5V I _C = 500mA V _{CE} = 5V
Current Gain-Bandwidth Product	f _T	100	200		MHz	I _C = 50mA V _{CE} = 10V

* Pulse Test : Pulse Width = 0.3ms, Duty Cycle = 1%

TYPICAL CHARACTERISTICS
 ($T_A=25^{\circ}\text{C}$ unless otherwise noted)

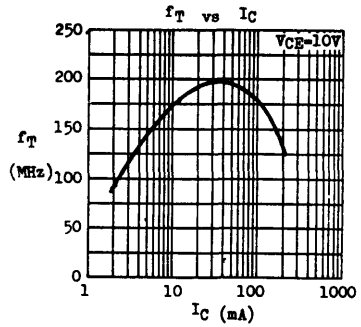
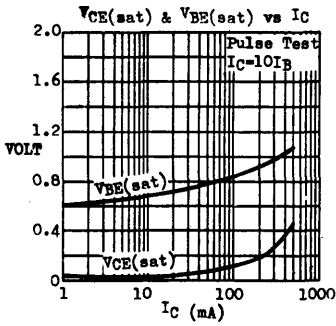
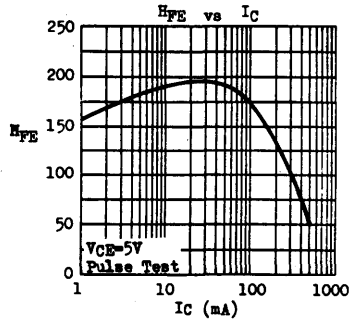
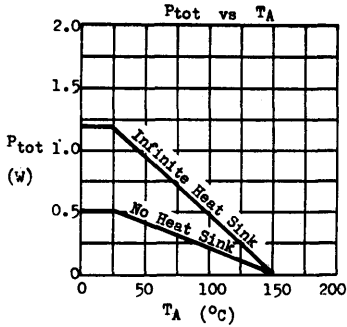

MPS-L01

NPN SILICON GENERAL PURPOSE HIGH VOLTAGE TRANSISTORS

THE MPS-L01 IS NPN SILICON PLANAR EPITAXIAL TRANSISTOR FOR GENERAL PURPOSE HIGH VOLTAGE AMPLIFIERS AND GAS DISCHARGE DISPLAY DRIVING APPLICATIONS. IT FEATURES LOW COLLECTOR-EMITTER SATURATION VOLTAGE AND HIGH FREQUENCY RESPONSE.

CASE TO-92A



EBC

ABSOLUTE MAXIMUM RATING

Collector-Base Voltage	V_{CB0}	140V *
Collector-Emitter Voltage	V_{CE0}	120V *
Emitter-Base Voltage	V_{EB0}	5V
Collector Current	I_C	100mA
Collector Peak Current ($t \leq 10\mu\text{S}$)	I_{CM}	500mA
Total Power Dissipation @ $T_C \leq 25^\circ\text{C}$	P_{tot}	1.2W
@ $T_A \leq 25^\circ\text{C}$		500mW
Operating Junction & Storage Temperature	T_j, T_{stg}	-55 to +150°C

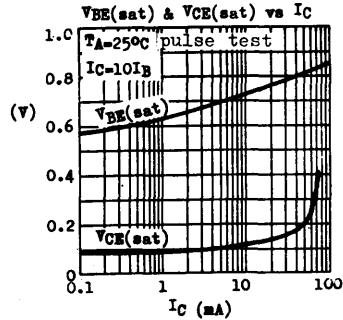
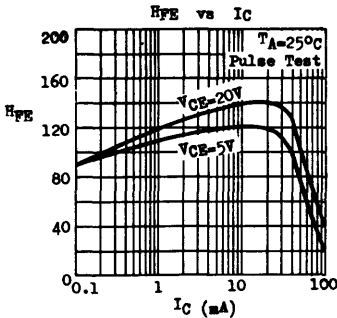

ELECTRICAL CHARACTERISTICS (TA=25°C unless otherwise noted)

PARAMETER	SYMBOL	MIN	TYP	MAX	UNIT	TEST CONDITIONS
Collector-Base Breakdown Voltage	EVCEO *	140			V	IC=0.1mA IE=0
Collector-Emitter Breakdown Voltage	LVCEO *	120			V	IC=1mA IB=0
Emitter-Base Breakdown Voltage	EVBE0	5			V	IC=10µA IC=0
Collector Cutoff Current	ICE0			1	µA	VCE=75V IE=0
Collector Cutoff Current	ICER			10	µA	VCE=100V REE=1kΩ
Emitter Cutoff Current	IEE0			0.1	µA	VBE=4V IC=0
Collector-Emitter Saturation Voltage	VCE(sat)			0.2	V	IC=10mA IB=1mA
				0.3	V	IC=50mA IB=5mA
Base-Emitter Saturation Voltage	VBE(sat)			1.2	V	IC=10mA IB=1mA
				1.4	V	IC=50mA IB=5mA
D.C. Current Gain	HFE	50		300		IC=10mA VCE=5V
Current Gain Bandwidth Product	fT	60	150		MHz	IC=10mA VCE=10V
Collector-Base Capacitance	Cob		4	8	pF	VCB=10V IE=0 f=1MHz
Small Signal Current Gain	hfe	30				IC=1mA VCE=10V f=1kHz

* Special classification of breakdown voltage is available as follows.

ORDER PART NO.	EVCEO (min)	LVCEO (min)
MPS-L01	140V	120V
MPS-L01A	140V	140V
MPS-L01B	170V	170V

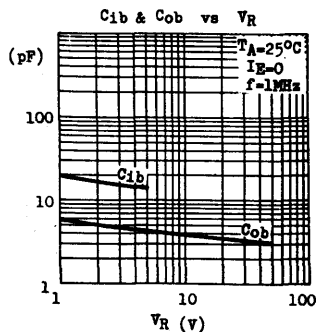
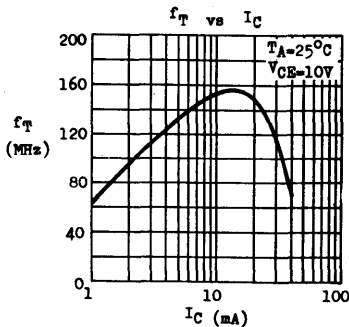

MSB492

PNP SILICON PLANAR EPITAXIAL MEDIUM POWER TRANSISTOR

THE MSB492 IS PNP SILICON PLANAR EPITAXIAL TRANSISTOR INTENDED TO REPLACE THE GERMANIUM TYPE 2SB492. IT FEATURES HIGH CURRENT CAPACITY AND IS SUITABLE FOR STROBO FLASH AND AUDIO POWER AMPLIFIER APPLICATIONS.

THE MSB492 IS PACKED IN TO-92A PLASTIC CASE WITH OPTIONAL X-67 HEAT SINK.

TO-92A CASE



EBC

WITH X-67 HEAT SINK

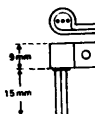

ABSOLUTE MAXIMUM RATINGS

Collector-Base Voltage	-V _{CB0}	25V
Collector-Emitter Voltage (R _{BB} =100Ω)	-V _{CE0}	25V
Emitter-Base Voltage	-V _{EB0}	6V
Collector Current	-I _C	2A
Collector Peak Current (t ≤ 10μs)	-I _{CM}	4A
Total Power Dissipation @ T _C ≤ 25°C	P _{tot}	1.5W
With X-67 Heat Sink, T _A ≤ 25°C		800mW
.No Heat Sink, T _A ≤ 25°C		625mW
Operating Junction & Storage Temperature	T _j & T _{stg}	-55 to +150°C

ELECTRICAL CHARACTERISTICS (T_A=25°C unless otherwise noted)

PARAMETER	SYMBOL	MIN	TYP	MAX	UNIT	TEST CONDITIONS
Collector Cutoff Current	-I _{CBO}			10	μA	-V _{CE} =15V I _B =0
Emitter Cutoff Current	-I _{EBO}			10	μA	-V _{EB} =6V I _C =0
Collector-Emitter Saturation Voltage	-V _{CE(sat)} *	0.25	0.5		V	-I _C =1A -I _B =0.1A
Base-Emitter Saturation Voltage	-V _{BE(sat)} *	1	1.3		V	-I _C =1A -I _B =0.1A
D.C. Current Gain (note)	H _{FE 1} *	80	160	360		-I _C =0.2A -V _{CE} =1V
	H _{FE 2} *	40	75			-I _C =2A -V _{CE} =1V
Current Gain-Bandwidth Product	f _T		100		MHz	-I _C =0.1A -V _{CE} =4V
Collector-Base Capacitance	C _{ob}		28		pF	-V _{CB} =10V I _E =0 f=1MHz

* Pulse Test : Pulse Width=0.3ms, Duty Cycle=1%

note : H_{FE 1} is classified as follows. Group B : 80-160 Group C : 120-240

Group D : 180-360

TYPICAL CHARACTERISTICS (T_A=25°C, Pulse Test)

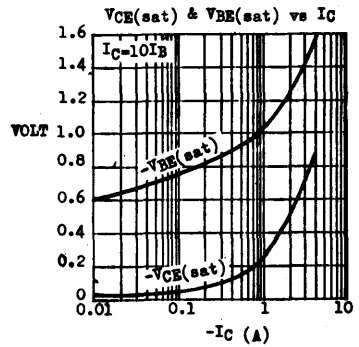
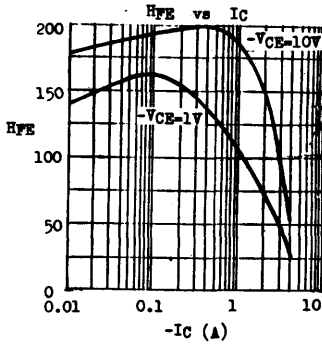

TYPICAL APPLICATION : STROBO FLASH UNIT

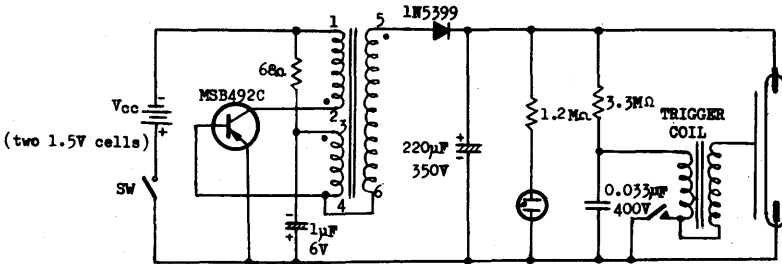

Coil D.C. Resistance	1-2	:	0.15 ohm
	3-4	:	0.25 ohm
	5-6	:	190 ohm
Coil Turn Ratio	1-2	:	1.5
	3-4	:	1.0
	5-6	:	200
Standby Current	150mA	@	Vcc=3V
	60mA	@	Vcc=2V
Recycling Time	9 Sec. using zinc carbon battery.		

RN4918 RN4919 RN4920

PNP SILICON EPITAXIAL BASE POWER TRANSISTORS

THE RN 4918, RN 4919 AND RN 4920 ARE PNP SILICON EPITAXIAL BASE POWER TRANSISTORS DESIGNED FOR SWITCHING, DRIVER AND OUTPUT STAGES IN AUDIO AMPLIFIERS. THE RN 4918, RN 4919 AND RN 4920 ARE COMPLEMENTARY TO RN 4921, RN 4922 AND RN 4923 RESPECTIVELY.

CASE TO-220B



BCE

ABSOLUTE MAXIMUM RATINGS

Collector-Base Voltage	- V _{CB0}	40V	60V	80V
Collector-Emitter Voltage	- V _{CE0}	40V	60V	80V
Emitter-Base Voltage	- V _{EB0}		5V	
Collector Current	- I _C		3A	
Base Current	- I _B		1A	
Total Power Dissipation @ T _C ≤25°C	P _{tot}		30W	
Operating and Storage Junction Temperature Range	T _j , T _{stg}		-55 to +150°C	

RN 4918 RN 4919 RN 4920

THERMAL RESISTANCE

Junction to Case	θ _{jc}	4.17°C/W max.
------------------	-----------------	---------------

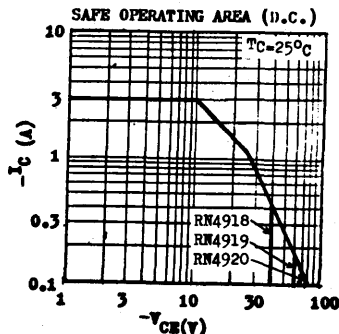
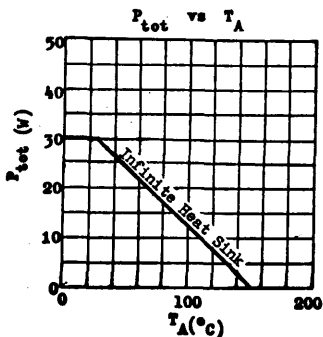

RN4918 RN4919 RN4920

ELECTRICAL CHARACTERISTICS ($T_A=25^\circ\text{C}$ unless otherwise noted)

PARAMETER	SYMBOL	MIN	MAX	UNIT	TEST CONDITIONS
Collector-Emitter Breakdown Voltage RN4918 RN4919 RN4920	$-V_{CE0}^*$	40 60 80		V V V	$-I_C=0.1A$ $I_B=0$
Collector Cutoff Current	$-I_{CBO}$		0.1	mA	$V_{CE}=\text{Rated}$ V_{CB0} $I_B=0$
Collector Cutoff Current RN4918 RN4919 RN4920	$-I_{CBO}$		0.5 0.5 0.5	mA mA mA	$-V_{CE}=20V$ $I_B=0$ $-V_{CE}=30V$ $I_B=0$ $-V_{CE}=40V$ $I_B=0$
Collector Cutoff Current	$-I_{CEV}$		0.1 0.5	mA mA	$V_{CE}=\text{Rated}$ V_{CE0} $-V_{EB}=1.5V$ $V_{CE}=\text{Rated}$ V_{CE0} $-V_{EB}=1.5V$ $T_C=125^\circ\text{C}$
Emitter Cutoff Current	$-I_{EBO}$		1	mA	$-V_{EB}=5V$ $I_C=0$
Base-Emitter voltage	$-V_{BE}^*$		1.3	V	$-I_C=1A$ $-V_{CE}=1V$
Base-Emitter Saturation Voltage	$-V_{BE(sat)}^*$		1.3	V	$-I_C=1A$ $-I_B=0.1A$
Collector-Emitter Saturation Voltage	$-V_{CE(sat)}^*$		0.6	V	$-I_C=1A$ $-I_B=0.1A$
D.C. Current Gain	h_{FE}^*	40 20 10	100		$-I_C=50mA$ $-V_{CE}=1V$ $-I_C=500mA$ $-V_{CE}=1V$ $-I_C=1A$ $-V_{CE}=1V$
Current Gain-Bandwidth Product	f_T		3	MHz	$-I_C=250mA$ $-V_{CE}=10V$
Collector-Base Capacitance	C_{ob}		100	pF	$-V_{CB}=10V$ $I_B=0$ $f=1MHz$
Small Signal Current Gain	h_{fe}		25		$-I_C=250mA$ $-V_{CE}=10V$ $f=1kHz$

* Pulse Test : Pulse Width=0.3ms, Duty Cycle=1%

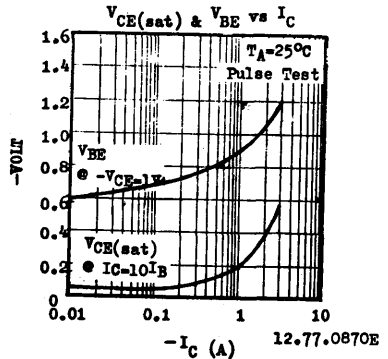
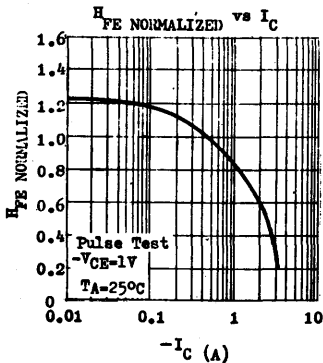

RN4921 RN4922 RN4923

NPN SILICON EPITAXIAL BASE POWER TRANSISTORS

THE RN 4921, RN 4922 AND RN 4923 ARE NPN SILICON EPITAXIAL BASE POWER TRANSISTORS DESIGNED FOR SWITCHING, DRIVER AND OUTPUT STAGES IN AUDIO AMPLIFIERS. THE RN 4921, RN 4922 AND RN 4923 ARE COMPLEMENTARY TO RN 4918, RN 4919 AND RN 4920 RESPECTIVELY.

CASE TO-220B



ABSOLUTE MAXIMUM RATINGS

Collector-Base Voltage	V_{CB0}	40V	60V	80V
Collector-Emitter Voltage	V_{CE0}	40V	60V	80V
Emitter-Base Voltage	V_{EB0}		5V	
Collector Current	I_C		3A	
Base Current	I_B		1A	
Total Power Dissipation @ $T_C < 25^\circ\text{C}$	P_{tot}		30W	
Operating and Storage Junction Temperature Range	T_j, T_{stg}		-55 to +150°C	

RN 4921 RN 4922 RN 4923

THERMAL RESISTANCE

Junction to Case	θ_{jc}	4.17°C/W max.
------------------	---------------	---------------

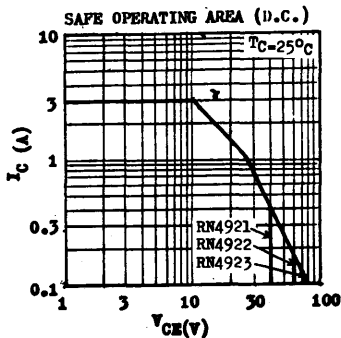
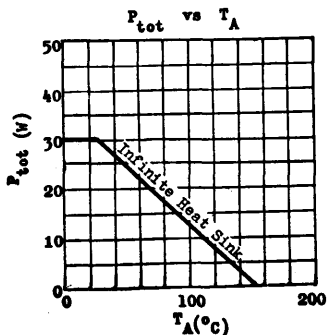

RN4921 RN4922 RN4923

ELECTRICAL CHARACTERISTICS ($T_A=25^\circ\text{C}$ unless otherwise noted)

PARAMETER	SYMBOL	MIN	MAX	UNIT	TEST CONDITIONS
Collector-Emitter Breakdown Voltage	V_{CE0} *				$I_C=0.1A$ $I_B=0$
	RN 4921	40		V	
	RN 4922	60		V	
	RN 4923	80		V	
Collector Cutoff Current	I_{CBO}		0.1	mA	$V_{CB}=\text{Rated } V_{CE0}$ $I_E=0$
Collector Cutoff Current	I_{CBO}		0.5	mA	$V_{CE}=20V$ $I_B=0$
	RN 4922		0.5	mA	$V_{CE}=30V$ $I_B=0$
	RN 4923		0.5	mA	$V_{CE}=40V$ $I_B=0$
Collector Cutoff Current	I_{CEV}		0.1	mA	$V_{CE}=\text{Rated } V_{CE0}$ $V_{EB}=1.5V$
			0.5	mA	$V_{CE}=\text{Rated } V_{CE0}$ $V_{EB}=1.5V$ $T_C=125^\circ\text{C}$
Emitter Cutoff Current	I_{EBO}		1	mA	$V_{EB}=5V$ $I_C=0$
Base-Emitter voltage	V_{BE} *		1.3	V	$I_C=1A$ $V_{CE}=1V$
Base-Emitter Saturation Voltage	$V_{BE(sat)}$ *		1.3	V	$I_C=1A$ $I_B=0.1A$
Collector-Emitter Saturation Voltage	$V_{CE(sat)}$ *		0.6	V	$I_C=1A$ $I_B=0.1A$
D.C. Current Gain	h_{FE} *	40			$I_C=50mA$ $V_{CE}=1V$
		20	100		$I_C=500mA$ $V_{CE}=1V$
		10			$I_C=1A$ $V_{CE}=1V$
Current Gain-Bandwidth Product	f_T		3	MHz	$I_C=250mA$ $V_{CE}=10V$
Collector-Base Capacitance	C_{ob}		100	pF	$V_{CB}=10V$ $I_E=0$ $f=1MHz$
Small Signal Current Gain	h_{fe}	25			$I_C=250mA$ $V_{CE}=10V$ $f=1kHz$

* Pulse Test : Pulse Width=0.3ms, Duty Cycle=1%

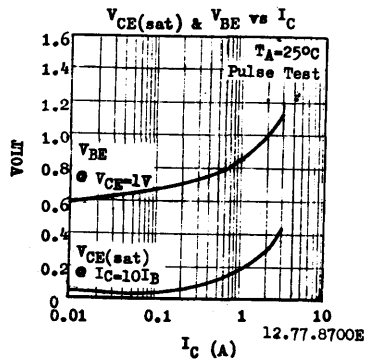
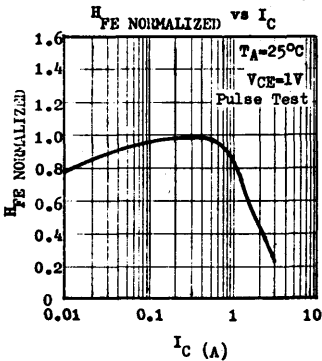

NPN SILICON PLANAR PHOTO TRANSISTOR CHIP

THE S110 IS AN NPN SILICON PLANAR PHOTO TRANSISTOR CHIP DESIGNED FOR APPLICATIONS REQUIRING HIGH RADIATION SENSITIVITY AND STABLE CHARACTERISTICS.

THE REAR SURFACE IS COVERED BY A GOLD LAYER TO ELIMINATE THE NECESSITY FOR PREFORMS IN ASSEMBLY, AND THERMAL COMPRESSION OR ULTRASONIC BONDING TECHNIQUE MAY BE USED UPON THE ALUMINIUM TOP CONTACTS.

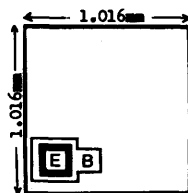

CHIP GEOMETRY

PHYSICAL DETAILS

Chip Size : 1.016 ± 0.101mm square (40 ± 0.4mil square)
 Chip Thickness : 0.15 ± 0.025mm (6 ± 1mil)
 Bonding Pads Area : Emitter : 0.143mm square
 Base : 0.143mm square

PRINCIPAL DEVICE : FPT 100 series

ELECTRICAL CHARACTERISTICS IN DARKNESS AT $T_A=25^{\circ}\text{C}$

PARAMETER	SYMBOL	MIN	TYP	MAX	UNIT	TEST CONDITIONS
Collector-Emitter Breakdown Voltage	BV_{CEO}	30			V	$I_C=1\mu\text{A}$ $I_B=0$
Emitter-Collector Breakdown Voltage	BV_{ECO}	5			V	$I_E=0.1\text{mA}$ $I_B=0$
Collector Cutoff Current	I_{CEO}			100	nA	$V_{CE}=15\text{V}$ $I_B=0$
D.C. Current Gain	H_{FE} *	150	350	850		$V_{CE}=5\text{V}$ $I_C=1\text{mA}$

* H_{FE} can be grouped at max/min = 2 : 1 upon request.

LIGHT CURRENT (I_L) CHARACTERISTICS

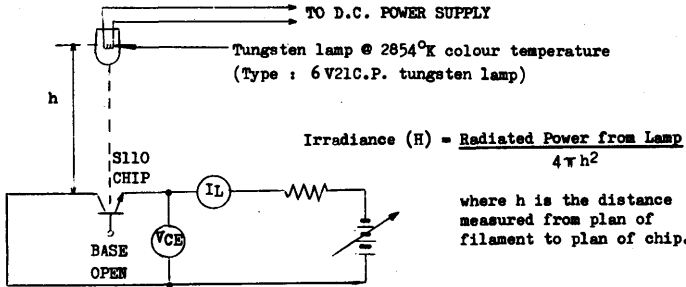
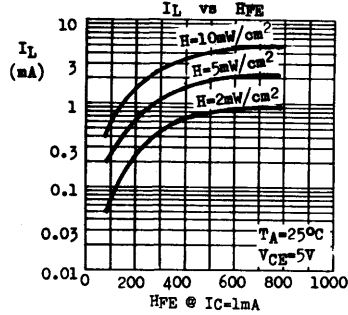
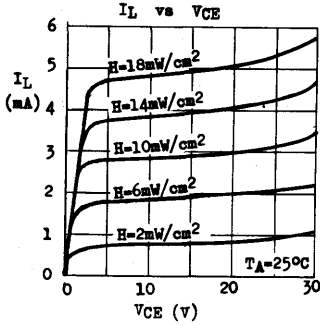

SPECTRAL CHARACTERISTICS ($T_A = 25^\circ\text{C}$)

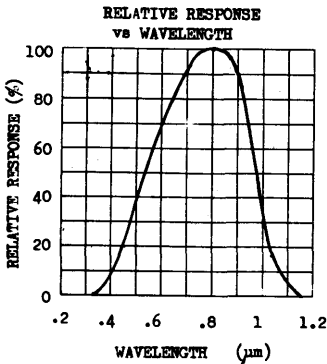

SWITCHING CHARACTERISTICS ($T_A = 25^\circ\text{C}$)

The switching characteristics is measured with the following circuit arrangement.

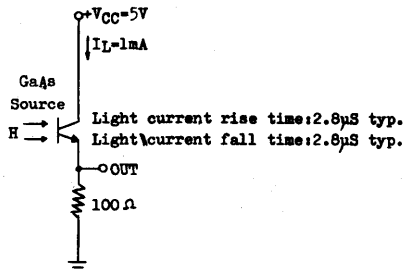

2N930 2N3548

COMPLEMENTARY

SILICON AF LOW NOISE SMALL SIGNAL TRANSISTORS

THE 2N930 (NPN) AND 2N3548 (PNP) ARE SILICON PLANAR EPITAXIAL TRANSISTORS FOR USE IN AF SMALL SIGNAL AMPLIFIERS AND DIRECT COUPLED CIRCUITS.

CASE TO-18



CBE

ABSOLUTE MAXIMUM RATINGS For p-p devices, voltage and current values are negative

		2N930(NPN)	2N3548(PNP)
Collector-Base Voltage	V _{CB0}	45V	60V
Collector-Emitter Voltage	V _{CE0}	45V	45V
Emitter-Base Voltage	V _{EB0}	5V	6V
Collector Current	I _C	100mA **	100mA
Total Power Dissipation (T _A ≤ 25°C)	P _{tot}	300mW	400mW
Junction Temperature	T _j	175°C	200°C
Storage Temperature Range	T _{stg}	-65 to 200°C	

** 30mA in JEDEC registration.

ELECTRICAL CHARACTERISTICS (T_A=25°C unless otherwise noted)

PARAMETER	SYMBOL	2N930		2N3548		UNIT	TEST CONDITIONS
		MIN	MAX	MIN	MAX		
Collector-Base Breakdown Voltage	LV _{CB0}	45		45		V	I _C =10mA (Pulsed) I _B =0
Collector Cutoff Current	I _{CES}		10		10	nA	V _{CE} =45V V _{BE} =0
			10		10	μA	V _{CE} =45V V _{BE} =0 T _A =170°C
Emitter Cutoff Current	I _{EB0}		10		10	nA	V _{EB} =5V I _C =0
Collector-Emitter Saturation Voltage	V _{CE(sat)}		1		1	V	I _C =10mA I _B =0.5mA
Base-Emitter Breakdown Voltage	V _{BE(sat)}	0.6	1	0.6	1	V	I _C =10mA I _B =0.5mA
D.C. Current Gain	h _{FE}	100	300	100	300		I _C =10mA V _{CE} =5V
					150		I _C =100μA V _{CE} =5V
		150					I _C =500μA V _{CE} =5V
			600		600		I _C =10mA V _{CE} =5V
		20		20		I _C =10μA V _{CE} =5V T _A =-55°C	
Current Gain-Bandwidth Product	f _T	30				MHz	I _C =0.5mA V _{CE} =5V
				60	150	MHz	I _C =1mA V _{CE} =5V
Collector-Base Capacitance	C _{ob}		8		8	pF	V _{CB} =5V I _E =0 f=1MHz
Noise Figure	N _F		3		4	dB	I _C =10μA V _{CE} =5V R _G =10Ω, f=10Hz-15KHz

PARAMETER	SYMBOL	2N930	2N3548	UNIT	TEST CONDITIONS
		MIN	MAX		
Small Signal Current Gain	h_{fe}	150	600		$I_C=1mA$ $V_{CE}=5V$ $f=1KHz$

COMMON BASE h - PARAMETERS (for 2N930 only)

h - PARAMETER	SYMBOL	MIN	MAX	UNIT	TEST CONDITIONS
Input Impedance	h_{ib}	25	32	Ω	$I_C=1mA$ $V_{CB}=5V$ $f=1KHz$
Output Admittance	h_{ob}		1	μS	
Voltage Feedback Ratio	h_{rb}		6	$\times 10^{-4}$	

TYPICAL CHARACTERISTICS AT $T_A=25^\circ C$

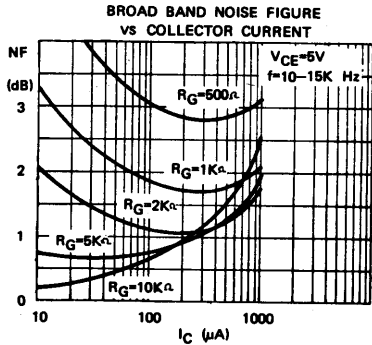
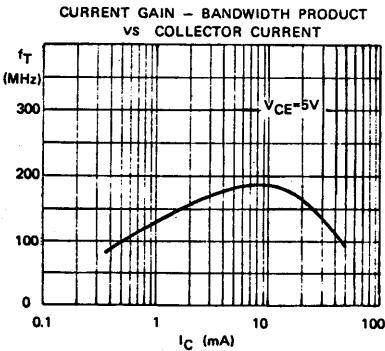
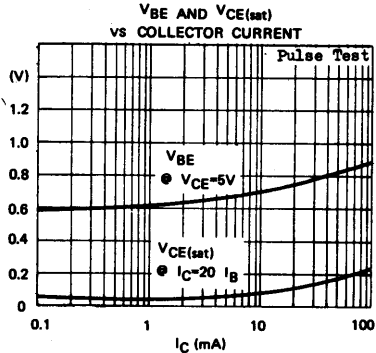
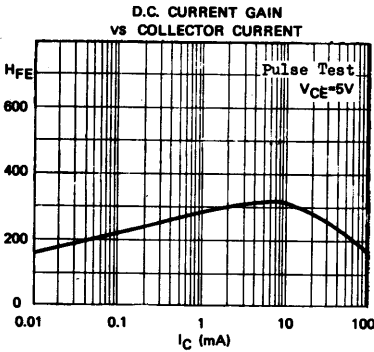

2N2102 2N4036

COMPLEMENTARY

SILICON AF MEDIUM POWER AMPLIFIERS & SWITCHES

THE 2N2102(NPN) AND 2N4036(PNP) ARE COMPLEMENTARY SILICON PLANAR EPITAXIAL TRANSISTORS FOR USE IN AF MEDIUM POWER DRIVERS AND OUTPUTS, AS WELL AS FOR SWITCHING APPLICATIONS.

CASE TO-39



ABSOLUTE MAXIMUM RATINGS For p-n-p devices, voltage and current values are negative.

		2N2102(NPN)	2N4036(PNP)
Collector-Base Voltage	VCBO	120V	90V
Collector-Emitter Voltage	VCEO	65V	65V
Emitter-Base Voltage	VEBO	7V	7V
Collector Current	IC		1A
Total Power Dissipation ($T_C \leq 25^\circ\text{C}$)	P _{tot}		7W
	($T_A \leq 25^\circ\text{C}$)		1W
Operating Junction & Storage Temperature T _j , T _{stg}			-65 to 200°C

ELECTRICAL CHARACTERISTICS (T_A=25°C unless otherwise noted)

PARAMETER	SYMBOL	2N2102		2N4036		UNIT	TEST CONDITIONS
		MIN	MAX	MIN	MAX		
Collector-Base Breakdown Voltage	EV _{CB0}	120		90		V	I _C =0.1mA I _E =0
Collector-Emitter Breakdown Voltage	LV _{CEB} *	80				V	I _C =100mA R _{BE} =10Ω
Collector-Emitter Breakdown Voltage	LV _{CEV} *			85		V	I _C =100mA V _{EB} =1.5V
Collector-Emitter Breakdown Voltage	LV _{CEO} *	65		65		V	I _C =100mA I _B =0
Emitter-Base Breakdown Voltage	EV _{EB0}	7		7		V	I _E =0.1mA I _C =0
Collector Cutoff Current	IC _{B0}		2		100	nA	V _{CB} =60V I _E =0
					100	nA	V _{CB} =90V I _E =0
Collector Cutoff Current	ICEV				100	μA	V _{CE} =30V V _{EB} =1.5V T _A =150°C
Emitter Cutoff Current	IE _{B0}		5		20	nA	V _{EB} =5V I _C =0
D.C. Current Gain	h _{FE} *	10					I _C =0.01mA V _{CE} =10V
		20		20			I _C =0.1mA V _{CE} =10V
		40	120	40	140		I _C =150mA V _{CE} =10V
		15		20			I _C =500mA V _{CE} =10V
		10					I _C =1A V _{CE} =10V
		35					I _C =10mA V _{CE} =10V
				20	200		I _C =150mA V _{CE} =2V

2N2102 2N4036

PARAMETER	SYMBOL	2N2102		2N4036		UNIT	TEST CONDITIONS
		MIN	MAX	MIN	MAX		
Collector-Emitter Saturation Voltage	$V_{CE(sat)}$	0.5		0.65		V	$I_C=150mA$ $I_B=15mA$
Base-Emitter Saturation Voltage	$V_{BE(sat)}$	1.1		1.4		V	$I_C=150mA$ $I_B=15mA$
Current Gain-Bandwidth Product	f_T	60		60		MHz	$I_C=50mA$ $V_{CE}=10V$
Collector-Base Capacitance	C_{ob}	10		30		pF	$V_{CB}=10V$ $I_B=0$ $f=1MHz$
Emitter-Base Capacitance	C_{ib}	80		90		pF	$V_{EB}=0.5V$ $I_C=0$ $f=1MHz$
Noise Figure	NF	6				dB	$I_C=0.3mA$ $V_{CE}=10V$ $f=1kHz$ $R_G=510\Omega$
Turn-On Time	t_{on}			110		nS	$I_C=150mA$ $I_{B1}=15mA$ $V_{CC}=30V$
Turn-Off Time	t_{off}			700		nS	$I_C=150mA$ $I_{B1}=-I_{B2}=15mA$ $V_{CC}=30V$

* Pulse Test : Pulse Width=0.3mS, Duty Cycle=1%

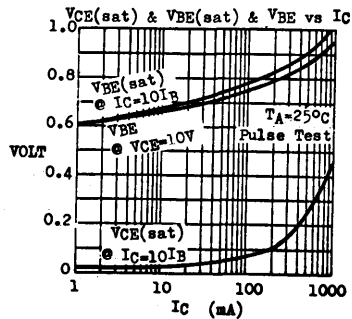
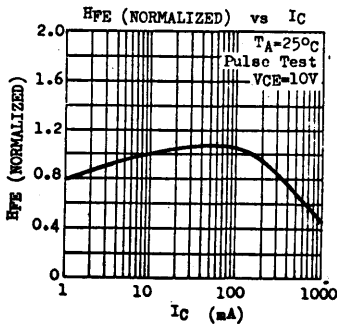
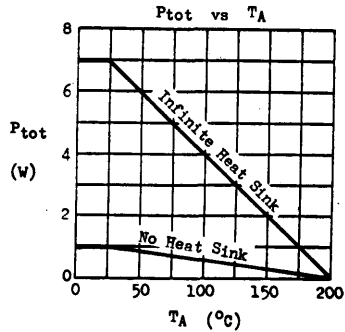
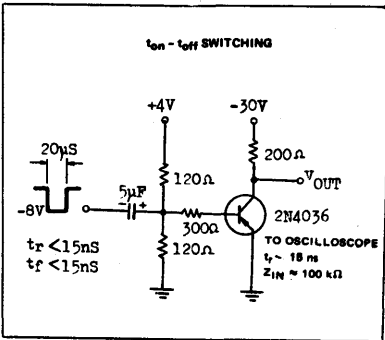

2N2222 2N2222A PN2222 PN2222A

NPN SILICON GENERAL PURPOSE AMPLIFIERS AND SWITCHES

THE 2N2222, 2N2222A, PN2222, PN2222A ARE NPN SILICON PLANAR EPITAXIAL TRANSISTORS FOR GENERAL PURPOSE AMPLIFIERS AND MEDIUM SPEED SWITCHING APPLICATIONS. THEY ARE COMPLEMENTARY TO THE PNP TYPE 2N2907, 2N2907A, PN2907, PN2907A RESPECTIVELY. THE 2N2222, 2N2222A ARE PACKED IN TO-18. THE PN2222, PN2222A ARE PACKED IN TO-92A.

CASE TO-18



CBE

2N2222
2N2222A

CASE TO-92A



EBC

PN2222
PN2222A

ABSOLUTE MAXIMUM RATINGS

		2N2222	2N2222A	PN2222	PN2222A
Collector-Base Voltage	V _{CBO}	60V	75V	60V	75V
Collector-Emitter Voltage	V _{CEO}	30V	40V	30V	40V
Emitter-Base Voltage	V _{EBO}	5V	6V	5V	6V
Collector Current	I _C	0.8A	0.8A	0.8A	0.8A
Total Power Dissipation (T _C ≤ 25°C)	P _{tot}	1.8W	1.8W	1.2W	1.2W
	(T _A ≤ 25°C)	500mW	500mW	500mW	500mW
Junction Temperature	T _j	175°C	175°C	150°C	150°C
Storage Temperature Range	T _{stg}	-65 to 200°C		-55 to 150°C	

ELECTRICAL CHARACTERISTICS (T_A=25°C unless otherwise noted)

PARAMETER	SYMBOL	2N2222	2N2222A	UNIT	TEST CONDITIONS
		PN2222	PN2222A		
		MIN	MAX		
Collector-Base Breakdown Voltage	BV _{CBO}	60	75	V	I _C =0.01mA I _E =0
Collector-Emitter Breakdown Voltage	LV _{CEO} *	30	40	V	I _C =10mA I _B =0
Emitter-Base Breakdown Voltage	BV _{EBO}	5	6	V	I _E =0.01mA I _C =0
Collector Cutoff Current	I _{CBO}	10		nA	V _{CB} =50V I _E =0
			10	nA	V _{CB} =60V I _E =0
		10	10	μA	V _{CB} =50V I _E =0 T _A =150°C
			10	μA	V _{CB} =60V I _E =0 T _A =150°C
Collector Cutoff Current	ICEV		10	nA	V _{CE} =60V V _{EB} =3V
Emitter Cutoff Current	IEBO	10	10	nA	V _{EB} =3V I _C =0
Base Cutoff Current	IBL		20	nA	V _{CE} =60V V _{EB} =3V

2N2222 2N2222A PN2222 PN2222A

PARAMETER	SYMBOL	2N2222 PN2222		2N2222A PN2222A		UNIT	TEST CONDITIONS
		MIN	MAX	MIN	MAX		
Collector-Emitter Saturation Voltage	$V_{CE(sat)}$ *	0.4		0.3		V	$I_C=150mA$ $I_B=15mA$
		1.6		1.0		V	$I_C=500mA$ $I_B=50mA$
Base-Emitter Saturation Voltage	$V_{BE(sat)}$ *	1.3	0.6	1.2		V	$I_C=150mA$ $I_B=15mA$
		2.6		2.0		V	$I_C=500mA$ $I_B=50mA$
D.C. Current Gain	H_{FE} *	35		35			$I_C=0.1mA$ $V_{CE}=10V$
		50		50			$I_C=1mA$ $V_{CE}=10V$
		75		75			$I_C=10mA$ $V_{CE}=10V$
		100	300	100	300		$I_C=150mA$ $V_{CE}=10V$
		30		40			$I_C=500mA$ $V_{CE}=10V$
		50		50			$I_C=150mA$ $V_{CE}=1V$
				35		$I_C=10mA$ $V_{CE}=10V$ $T_A=-55^{\circ}C$	
Current Gain-Bandwidth Product	f_T	250		300		MHz	$I_C=20mA$ $V_{CE}=20V$
Collector-Base Capacitance	C_{ob}		8		8	pF	$V_{CB}=10V$ $I_E=0$ $f=100kHz$
Emitter-Base Capacitance	C_{ib}		25		25	pF	$V_{EB}=0.5V$ $I_C=0$ $f=100kHz$
Collector-Base Time Constant	$C_{c}rb'b'$				150	pS	$I_C=20mA$ $V_{CE}=20V$ $f=31.8MHz$
Noise Figure	NF				4	dB	$I_C=0.1mA$ $V_{CE}=10V$ $f=1kHz$ $R_G=1k\Omega$
Input Impedance	h_{ie}		2	8		$K\Omega$	$I_C=1mA$ $V_{CE}=10V$ $f=1kHz$
			0.25	1.25		$K\Omega$	$I_C=10mA$ $V_{CE}=10V$ $f=1kHz$
Voltage Feedback Ratio	h_{re}			8		$\times 10^{-4}$	$I_C=1mA$ $V_{CE}=10V$ $f=1kHz$
				4		$\times 10^{-4}$	$I_C=10mA$ $V_{CE}=10V$ $f=1kHz$
Small Signal Current Gain	h_{fe}		50	300			$I_C=1mA$ $V_{CE}=10V$ $f=1kHz$
			75	375			$I_C=10mA$ $V_{CE}=10V$ $f=1kHz$
Output Admittance	h_{oe}		5	35		μS	$I_C=1mA$ $V_{CE}=10V$ $f=1kHz$
			25	200		μS	$I_C=10mA$ $V_{CE}=10V$ $f=1kHz$
Delay Time	t_d				10	nS	$I_C=150mA$ $I_{B1}=15mA$ $V_{CC}=30V$
Rise Time	t_r				25	nS	$I_C=150mA$ $I_{B1}=15mA$ $V_{CC}=30V$
Storage Time	t_s				225	nS	$I_C=150mA$ $I_{B1}=-I_{B2}=15mA$ $V_{CC}=30V$
Fall Time	t_f				60	nS	$I_C=150mA$ $I_{B1}=-I_{B2}=15mA$ $V_{CC}=30V$

* Pulse Test : Pulse Width=0.3mS, Duty Cycle=1%

2N2222 2N2222A PN2222 PN2222A

SWITCHING TIME TEST CIRCUITS

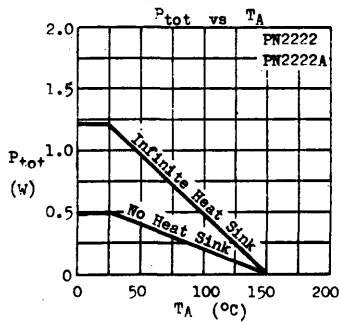
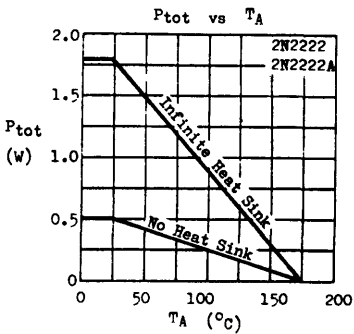
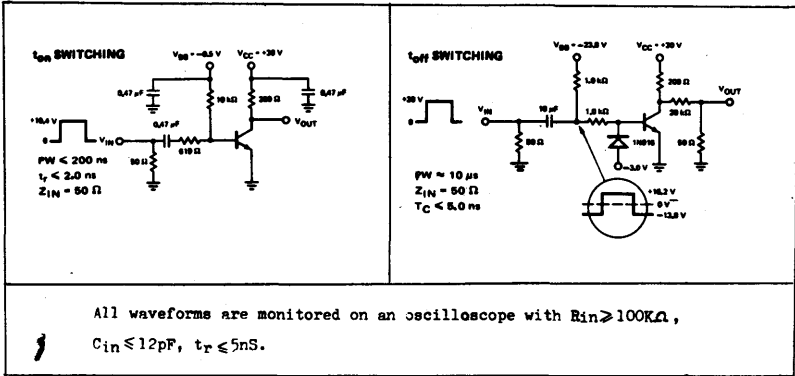

2N2222 2N2222A PN2222 PN2222A

TYPICAL CHARACTERISTICS

($T_A=25^\circ\text{C}$ unless otherwise noted)

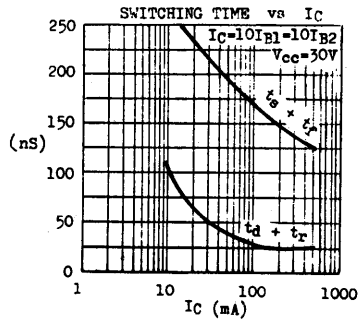
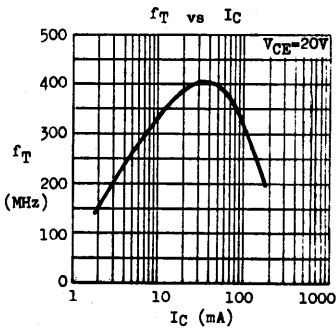
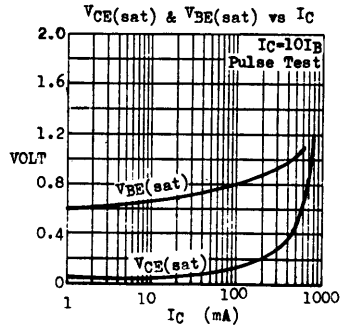
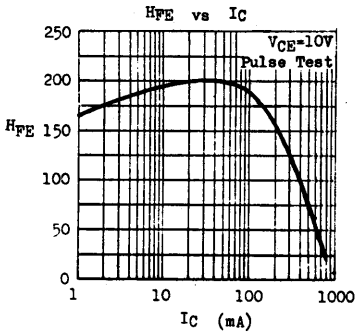

2N2586 2N3964
COMPLEMENTARY
SILICON AF LOW NOISE SMALL SIGNAL TRANSISTORS

THE 2N2586 (NPN) AND 2N3964 (PNP) ARE COMPLEMENTARY SILICON PLANAR EPITAXIAL TRANSISTORS FOR USE IN AF LOW NOISE SMALL SIGNAL AMPLIFIER CIRCUITS.

CASE TO-18



CBE

<u>ABSOLUTE MAXIMUM RATINGS</u>		<small>For power devices, voltage and current values are negative.</small>		<u>2N2586(NPN)</u>	<u>2N3964(PNP)</u>
Collector-Base Voltage	V _{CB0}	60V	45V		
Collector-Emitter Voltage	V _{CE0}	45V	45V		
Emitter-Base Voltage	V _{EB0}	6V	6V		
Collector Current	I _C	100mA**	200mA		
Total Power Dissipation (T _C ≤ 25°C)	P _{tot}	600mW	1.2W		
(T _A ≤ 25°C)		300mW	360mW		
Junction Temperature	T _j	175°C	200°C		
Storage Temperature Range	T _{stg}	-65 to 200°C			

** 30mA in JEDEC registration.

ELECTRICAL CHARACTERISTICS (T_A=25°C unless otherwise noted)

PARAMETER	SYMBOL	2N2586		2N3964		UNIT	TEST CONDITIONS
		MIN	MAX	MIN	MAX		
Collector-Base Breakdown Voltage	BV _{CB0}	60		45		V	I _C =0.01mA I _E =0
Collector-Emitter Breakdown Voltage	BV _{CE0}			45		V	I _C =0.01mA V _{BE} =0
Collector-Emitter Breakdown Voltage	LV _{CE0}	45				V	I _C =10mA(Pulsed) I _B =0
				45		V	I _C =5mA(Pulsed) I _B =0
Emitter-Base Breakdown Voltage	BV _{EB0}	6		6		V	I _E =0.01mA I _C =0
Collector Cutoff Current	I _{CB0}		2		10	nA	V _{CB} =45V I _E =0
Collector Cutoff Current	I _{CE0}	2			10	nA	V _{CE} =45V V _{BE} =0
					10	nA	V _{CE} =40V V _{BE} =0
				10		μA	V _{CE} =45V V _{BE} =0 T _A =170°C
				10		μA	V _{CE} =40V V _{BE} =0 T _A =150°C

2N2586 2N3964

PARAMETER	SYMBOL	2N2586		2N3964		UNIT	TEST CONDITIONS	
		MIN	MAX	MIN	MAX			
Emitter Cutoff Current	I _{EBO}	2				nA	V _{EB} =5V I _C =0	
				10		nA	V _{EB} =4V I _C =0	
Collector-Emitter Saturation Voltage	V _{CE(sat)}	0.5		0.25		V	I _C =10mA I _B =0.5mA	
				0.4		V	I _C =50mA I _B =5mA	
Base-Emitter Saturation Voltage	V _{BE(sat)}	0.7	0.9	0.9		V	I _C =10mA I _B =0.5mA	
				0.95		V	I _C =50mA I _B =5mA	
D.C. Current Gain	h _{FE}	80		180			I _C =1μA V _{CE} =5V	
		120	360	250	500		I _C =10μA V _{CE} =5V	
				250			I _C =100μA V _{CE} =5V	
				150			I _C =500μA V _{CE} =5V	
					250	600		I _C =1mA V _{CE} =5V
				600		200		I _C =10mA V _{CE} =5V
						180		I _C =50mA V _{CE} =5V
				40		100		I _C =10μA V _{CE} =5V
						800		T _A =-55°C
						90		I _C =1mA V _{CE} =5V T _A =100°C
Current Gain-Bandwidth Product	f _T	45		50	160		I _C =0.5mA V _{CE} =5V	
Collector-Base Capacitance	C _{ob}	7		6		pF	V _{CB} =5V I _E =0 f=1MHz	
Emitter-Base Capacitance	C _{ib}			15		pF	V _{EB} =0.5V I _C =0 f=1MHz	
Noise Figure	NF	3				dB	I _C =10μA V _{CE} =5V	
				3.5		dB	R _C =10KΩ f=1kHz	
				2		dB	I _C =1μA V _{CE} =5V	
						dB	R _C =1MΩ f=1kHz	
				2		dB	I _C =10μA V _{CE} =5V	
						dB	R _C =10KΩ f=10kHz	
Noise Figure	NF			2		dB	I _C =1μA V _{CE} =5V	
						dB	R _C =10KΩ f=10Hz-10kHz	
				2		dB	I _C =20μA V _{CE} =5V	
						dB	R _C =10KΩ f=10kHz	
				2		dB	I _C =20μA V _{CE} =5V	
						dB	R _C =10KΩ f=1kHz	
				4		dB	I _C =20μA V _{CE} =5V	
						dB	R _C =10KΩ f=100Hz	
Input Impedance	h _{ie}	4.5	18	6	20	KΩ	I _C =1mA V _{CE} =5V f=1kHz	
Voltage Feedback Ratio	h _{re}			10		x10 ⁻⁴	I _C =1mA V _{CE} =5V f=1kHz	
Small Signal Current Gain	h _{fe}	150	600	250	700		I _C =1mA V _{CE} =5V f=1kHz	
Output Admittance	h _{oe}	100		5	50	μS	I _C =1mA V _{CE} =5V f=1kHz	

2N2907 2N2907A PN2907 PN2907A

PNP SILICON GENERAL PURPOSE AMPLIFIERS AND SWITCHES

THE 2N2907, 2N2907A, PN2907, PN2907A ARE PNP SILICON PLANAR EPITAXIAL TRANSISTORS FOR GENERAL PURPOSE AMPLIFIERS AND MEDIUM SPEED SWITCHING APPLICATIONS. THEY ARE COMPLEMENTARY TO THE NPN TYPE 2N2222, 2N2222A, PN2222, PN2222A RESPECTIVELY. THE 2N2907, 2N2907A ARE PACKED IN TO-18. THE PN2907, PN2907A ARE PACKED IN TO-92A.

CASE TO-18



CBE

2N2907
2N2907A

CASE TO-92A



EBC

PN2907
PN2907A

ABSOLUTE MAXIMUM RATINGS

		2N2907	2N2907A	PN2907	PN2907A
Collector-Base Voltage	$-V_{CBO}$	60V	60V	60V	60V
Collector-Emitter Voltage	$-V_{CEO}$	40V	60V	40V	60V
Emitter-Base Voltage	$-V_{EBO}$	5V	5V	5V	5V
Collector Current	$-I_C$	0.6A	0.6A	0.6A	0.6A
Total Power Dissipation ($T_C \leq 25^\circ\text{C}$) ($T_A \leq 25^\circ\text{C}$)	P_{tot}	1.8W	1.8W	1.2W	1.2W
		400mW	400mW	500mW	500mW
Junction Temperature	T_j	200°C	200°C	150°C	150°C
Storage Temperature Range	T_{stg}	-65 to 200°C		-55 to 150°C	

ELECTRICAL CHARACTERISTICS ($T_A=25^\circ\text{C}$ unless otherwise noted)

PARAMETER	SYMBOL	2N2907	2N2907A	UNIT	TEST CONDITIONS
		PN2907	PN2907A		
		MIN	MAX		
Collector-Base Breakdown Voltage	$-BV_{CBO}$	60	60	V	$-I_C=0.01\text{mA}$ $I_E=0$
Collector-Emitter Breakdown Voltage	$-LV_{CEO}$ *	40	60	V	$-I_C=10\text{mA}$ $I_B=0$
Emitter-Base Breakdown Voltage	$-BV_{EBO}$	5	5	V	$-I_E=0.01\text{mA}$ $I_C=0$
Collector Cutoff Current	$-I_{CBO}$	20	10	nA	$-V_{CB}=50\text{V}$ $I_E=0$
		20	10	μA	$-V_{CB}=50\text{V}$ $I_E=0$ $T_A=150^\circ\text{C}$
Collector Cutoff Current	$-I_{CEV}$	50	50	nA	$-V_{CE}=30\text{V}$ $-V_{EB}=0.5\text{V}$
Base Cutoff Current	$-I_{BL}$	50	50	nA	$-V_{CE}=30\text{V}$ $-V_{EB}=0.5\text{V}$
Collector-Emitter Saturation Voltage	$-V_{CE(sat)}$ *	0.4	0.4	V	$-I_C=150\text{mA}$ $-I_B=15\text{mA}$
		1.6	1.6	V	$-I_C=500\text{mA}$ $-I_B=50\text{mA}$

2N2907 2N2907A PN2907 PN2907A

PARAMETER	SYMBOL	2N2907		2N2907A		UNIT	TEST CONDITIONS
		PN2907	MIN MAX	PN2907A	MIN MAX		
Base-Emitter Saturation Voltage	$V_{BE(sat)}$ *	1.3		1.3		V	$-I_C=150mA$ $-I_B=15mA$
		2.6		2.6		V	$-I_C=500mA$ $-I_B=50mA$
D.C. Current Gain	H_{FE} *	35		75			$-I_C=0.1mA$ $-V_{CE}=10V$
		50		100			$-I_C=1mA$ $-V_{CE}=10V$
		75		100			$-I_C=10mA$ $-V_{CE}=10V$
		100	300	100	300		$-I_C=150mA$ $-V_{CE}=10V$
		30		50			$-I_C=500mA$ $-V_{CE}=10V$
Current Gain-Bandwidth Product	f_T	200		200		MHz	$-I_C=50mA$ $-V_{CE}=20V$
Collector-Base Capacitance	C_{ob}	8		8		pF	$-V_{CE}=10V$ $I_B=0$ $f=100kHz$
Emitter-Base Capacitance	C_{ib}	30		30		pF	$-V_{EB}=2V$ $I_C=0$ $f=100kHz$
Turn-On Time	t_{on}			45		nS	$-I_C=150mA$ $-I_{B1}=15mA$ $-V_{CC}=30V$
Turn-Off Time	t_{off}			100		nS	$-I_C=150mA$ $-I_{B1}=I_{B2}=15mA$ $-V_{CC}=6V$
Delay Time	t_d	10		10		nS	$-I_C=150mA$ $-I_{B1}=15mA$ $-V_{CC}=30V$
Rise Time	t_r	40		40		nS	$-I_C=150mA$ $-I_{B1}=15mA$ $-V_{CC}=30V$
Storage Time	t_s	80		80		nS	$-I_C=150mA$ $-I_{B1}=I_{B2}=15mA$ $-V_{CC}=6V$
Fall Time	t_f	30		30		nS	$-I_C=150mA$ $-I_{B1}=I_{B2}=15mA$ $-V_{CC}=6V$

* Pulse Test : Pulse Width=0.5ms, Duty Cycle=1%

2N2907 2N2907A PN2907 PN2907A

SWITCHING TIME TEST CIRCUITS

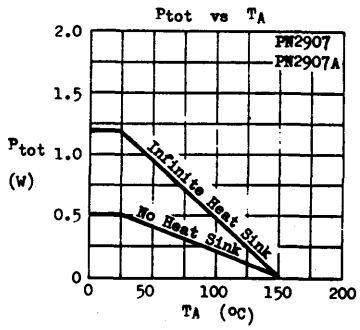
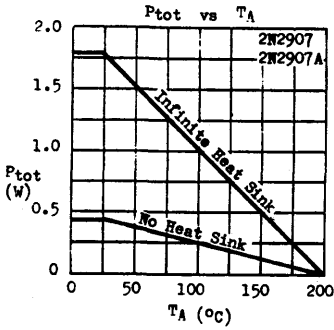
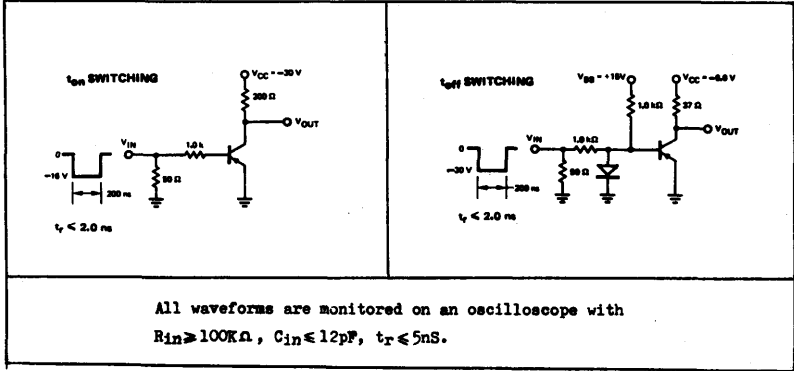

2N2907 2N2907A PN2907 PN2907A

TYPICAL CHARACTERISTICS

($T_A=25^\circ\text{C}$ unless otherwise noted)

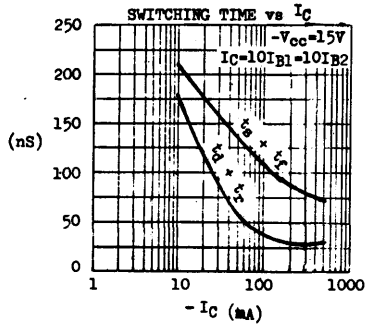
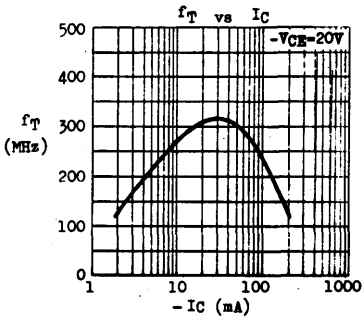
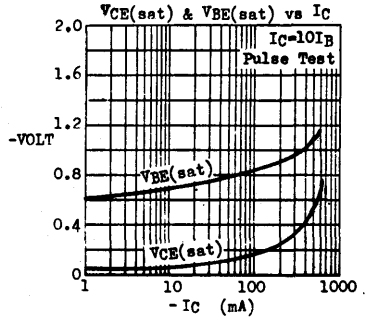
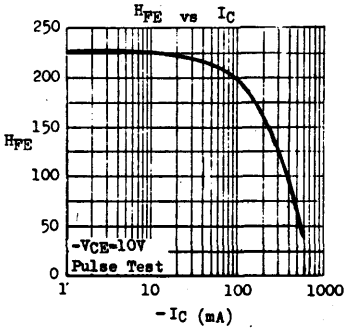

2N3019 2N3020

NPN SILICON AF MEDIUM POWER AMPLIFIERS & SWITCHES

THE 2N3019, 2N3020 ARE NPN SILICON PLANAR EPITAXIAL TRANSISTORS FOR AF MEDIUM POWER DRIVERS AND OUTPUTS, AS WELL AS FOR SWITCHING APPLICATIONS UP TO 1 AMPERE. THEY ARE COMPLEMENTARY TO THE PNP 2N4033, 2N4051.

CASE TO-39



C E B

ABSOLUTE MAXIMUM RATINGS

Collector-Base Voltage	V _{CB0}	140V
Collector-Emitter Voltage	V _{CE0}	80V
Emitter-Base Voltage	V _{EB0}	7V
Collector Current	I _C	1A
Total Power Dissipation (T _C ≤ 25°C) (T _A ≤ 25°C)	P _{tot}	5W 800mW
Operating Junction & Storage Temperature	T _j , T _{stg}	-65 to 200°C

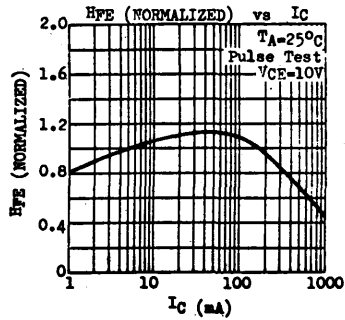
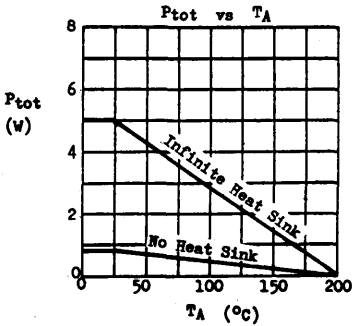

2N3019 2N3020

ELECTRICAL CHARACTERISTICS (T_A=25°C unless otherwise noted)

PARAMETER	SYMBOL	2N3019 MIN MAX	2N3020 MIN MAX	UNIT	TEST CONDITIONS
Collector-Base Breakdown Voltage	BV _{CB0}	140	140	V	I _C =0.1mA I _B =0
Collector-Emitter Breakdown Voltage	LV _{CE0} *	80	80	V	I _C =30mA I _B =0
Emitter-Base Breakdown Voltage	BV _{EB0}	7	7	V	I _E =0.1mA I _C =0
Collector Cutoff Current	I _{CBO}	10 10	10 10	nA μA	V _{CB} =90V I _B =0 V _{CE} =90V I _E =0 T _A =150°C
Emitter Cutoff Current	I _{EBO}	10	10	nA	V _{EB} =5V I _C =0
Collector-Emitter Saturation Voltage	V _{CE(sat)} *	0.2 0.5	0.2 0.5	V	I _C =150mA I _B =15mA I _C =500mA I _B =50mA
Base-Emitter Saturation Voltage	V _{BE(sat)} *	1.1	1.1	V	I _C =150mA I _B =15mA
D.C. Current Gain	h _{FE} *	50 90 100 300 50 15 40	30 100 40 120 40 120 30 100 15 15		I _C =0.1mA V _{CE} =10V I _C =10mA V _{CE} =10V I _C =150mA V _{CE} =10V I _C =500mA V _{CE} =10V I _C =1A V _{CE} =10V I _C =150mA V _{CE} =10V T _A =-55°C
Current Gain-Bandwidth Product	f _T	100	80	MHz	I _C =50mA V _{CE} =10V
Collector-Base Capacitance	C _{ob}	12	12	pF	V _{CB} =10V I _E =0
Emitter-Base Capacitance	C _{ib}	60	60	pF	V _{EB} =0.5V I _C =0 f=1MHz
Collector-Base Time Constant	C _{crbb'}	400	400	pS	I _C =10mA V _{CE} =10V f=4MHz
Noise Figure	NF	4		dB	I _C =0.1mA V _{CE} =10V R _g =1kΩ f=1kHz
Small Signal Current Gain (f=1kHz)	h _{fe}	80 400	30 200		I _C =1mA V _{CE} =5V

Pulse Test : Pulse Width=0.3ms, Duty Cycle=1%

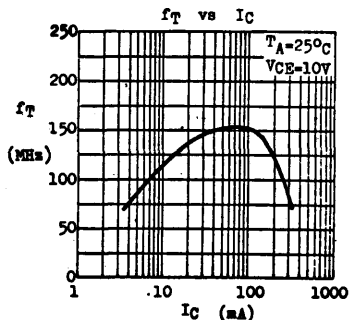
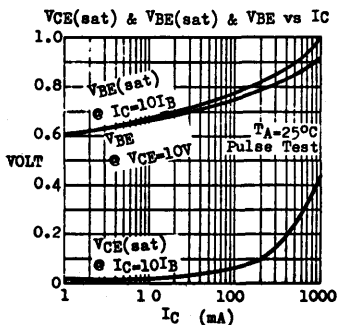

1.78.8100B

2N3053 2N4037

COMPLEMENTARY

SILICON AF MEDIUM POWER AMPLIFIERS & SWITCHES

THE 2N3053 (NPN) AND 2N4037 (PNP) ARE COMPLEMENTARY SILICON PLANAR EPITAXIAL TRANSISTORS FOR USE IN AF MEDIUM POWER DRIVERS AND OUTPUTS, AS WELL AS FOR SWITCHING APPLICATIONS.

CASE TO-39



C E B

ABSOLUTE MAXIMUM RATINGS

For p-n-p device, voltage and current values are negative.

		2N3053(NPN)	2N4037(PNP)
Collector-Base Voltage	V _{CB0}	60V	60V
Collector-Emitter Voltage	V _{CE0}	40V	40V
Emitter-Base Voltage	V _{EB0}	5V	7V
Collector Current	I _C	0.7A	1A
Total Power Dissipation (T _C ≤ 25°C)	P _{tot}		7W
(T _A ≤ 25°C)			1W
Operating Junction & Storage Temperature	T _j , T _{stg}	-65 to 200°C	

ELECTRICAL CHARACTERISTICS (T_A=25°C unless otherwise noted)

PARAMETER	SYMBOL	2N3053		2N4037		UNIT	TEST CONDITIONS
		MIN	MAX	MIN	MAX		
Collector-Base Breakdown Voltage	BV _{CB0}	60		60		V	I _C =0.1mA I _B =0
Collector-Emitter Breakdown Voltage	LV _{CE0} *	50				V	I _C =100mA RBE=10Ω
					60		V
Collector-Emitter Breakdown Voltage	LV _{CEV} *			60		V	I _C =100mA V _{EB} =1.5V
Collector-Emitter Breakdown Voltage	LV _{CEO} *	40		40		V	I _C =100mA I _B =0
Emitter-Base Breakdown Voltage	BV _{EB0}	5		7		V	I _E =0.1mA I _C =0
Collector Cutoff Current	I _{CEV}		0.25			μA	V _{CE} =30V V _{EB} =1.5V
Collector Cutoff Current	I _{CB0}			0.25		μA	V _{CB} =60V I _E =0
Collector Cutoff Current	I _{CE0}			5		μA	V _{CE} =30V I _B =0
Emitter Cutoff Current	I _{EB0}	0.25				μA	V _{EB} =4V I _C =0
					1		μA
Collector-Emitter Saturation Voltage	V _{CE(sat)} *	1.4		1.4		V	I _C =150mA I _B =15mA
Base-Emitter Saturation Voltage	V _{BE(sat)} *	1.7				V	I _C =150mA I _B =15mA
D.C. Current Gain	h _{FE} *			15			I _C =1mA V _{CE} =10V
		50	250	50	250		I _C =150mA V _{CE} =10V
		25					I _C =150mA V _{CE} =2.5V

PARAMETER	SYMBOL	2N3053 MIN MAX	2N4037 MIN MAX	UNIT	TEST CONDITIONS
Current Gain-Bandwidth Product	f_T	100	60	MHz	$I_C=5\text{mA}$ $V_{CE}=10\text{V}$
Collector-Base Capacitance	C_{ob}	15	30	pF	$V_{CB}=10\text{V}$ $I_E=0$ $f=1\text{MHz}$
Emitter-Base Capacitance	C_{ib}	80	90	pF	$V_{EB}=0.5\text{V}$ $I_C=0$ $f=1\text{MHz}$

* Pulse Test : Pulse Width=0.3ms, Duty Cycle=1%

TYPICAL CHARACTERISTICS

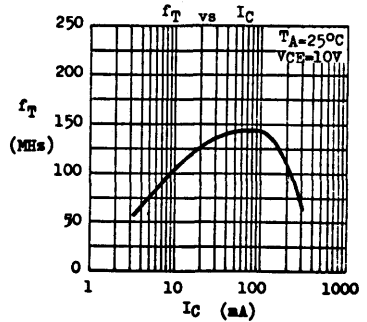
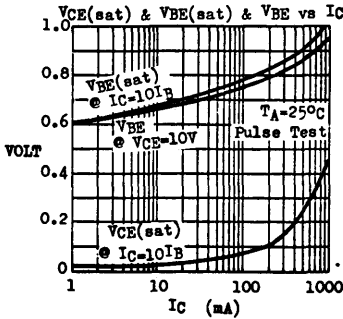
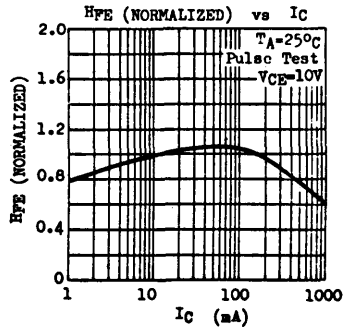
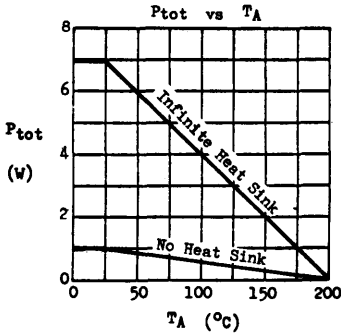

2N3107 through 2N3110

NPN SILICON AF MEDIUM POWER AMPLIFIERS & SWITCHES

THE 2N3107 THROUGH 2N3110 ARE NPN SILICON PLANAR EPITAXIAL TRANSISTORS FOR AF MEDIUM POWER DRIVERS AND OUTPUTS, AS WELL AS FOR SWITCHING APPLICATIONS UP TO 1 AMPERE. THEY ARE COMPLEMENTARY TO THE PNP 2N4032, 2N4030.

CASE TO-39



C E B

ABSOLUTE MAXIMUM RATINGS

		2N3107	2N3109
		2N3108	2N3110
Collector-Base Voltage	V_{CBO}	100V	80V
Collector-Emitter Voltage	V_{CEO}	60V	40V
Emitter-Base Voltage	V_{EBO}	7V	7V
Collector Current	I_C		1A
Total Power Dissipation ($T_C \leq 25^\circ C$)	P_{tot}		5W
			800mW
			($T_A \leq 25^\circ C$)
Operating Junction & Storage Temperature	T_j, T_{stg}	-65 to 200°C	

ELECTRICAL CHARACTERISTICS ($T_A=25^\circ C$ unless otherwise noted)

PARAMETER	SYMBOL	MIN	MAX	UNIT	TEST CONDITIONS
Collector-Base Breakdown Voltage 2N3107, 2N3108 2N3109, 2N3110	BV_{CBO}	100 80		V V	$I_C=0.1mA$ $I_E=0$
Collector-Emitter Breakdown Voltage 2N3107, 2N3108 2N3109, 2N3110	$LV_{CEO} *$	60 40		V V	$I_C=30mA$ $I_B=0$
Emitter-Base Breakdown Voltage	BV_{EBO}	7		V	$I_E=0.1mA$ $I_C=0$
Collector Cutoff Current	$ICES$		10	nA	$V_{CE}=60V$ $V_{BE}=0$
Collector Cutoff Current ($T_A=150^\circ C$)	$ICBO$		10	μA	$V_{CB}=60V$ $I_E=0$
Emitter Cutoff Current	$IEBO$		10	nA	$V_{EB}=5V$ $I_C=0$
Collector-Emitter Saturation Voltage	$V_{CE(sat)} *$	0.25 1.0		V V	$I_C=150mA$ $I_B=15mA$ $I_C=1A$ $I_B=0.1A$
Base-Emitter Saturation Voltage	$V_{BE(sat)} *$	1.1 2.0		V V	$I_C=150mA$ $I_B=15mA$ $I_C=1A$ $I_B=0.1A$
D.C. Current Gain 2N3107, 2N3109 only	$h_{FE} *$	35 100 40	300		$I_C=0.1mA$ $V_{CE}=10V$ $I_C=150mA$ $V_{CE}=1V$ $I_C=500mA$ $V_{CE}=10V$

2N3107 through 2N3110

PARAMETER	SYMBOL	MIN	MAX	UNIT	TEST CONDITIONS
2N3107, 2N3109 only	HFE *	30			IC=150mA VCE=10V TA=-55°C
D.C. Current Gain	HFE *	20	120		IC=0.1mA VCE=10V IC=150mA VCE=1V IC=500mA VCE=10V IC=150mA VCE=10V TA=-55°C
		40			
		25			
		15			
Current Gain-Bandwidth Product	f _T	70		MHz	IC=50mA VCE=10V
2N3107, 2N3109		60		MHz	
2N3108, 2N3110					
Collector-Base Capacitance	Cob		20	pF	VCE=10V IE=0 f=1MHz
2N3107, 2N3108			25	pF	
2N3109, 2N3110					
Emitter-Base Capacitance	Cib		80	pF	VEB=0.5V IC=0 f=1MHz
Noise Figure (f=1KHz)	NF		7	dB	IC=30mA VCE=10V RC=1KΩ
Turn-On Time	t _{on}		200	nS	IC=150mA I _{B1} =7.5mA
Turn-Off Time	t _{off}	2N3107, 2N3109	1000	nS	IC=150mA I _{B1} =I _{B2} =7.5mA
			2N3108, 2N3110	600	

* Pulse Test : Pulse Width=0.3ms, Duty Cycle=1%

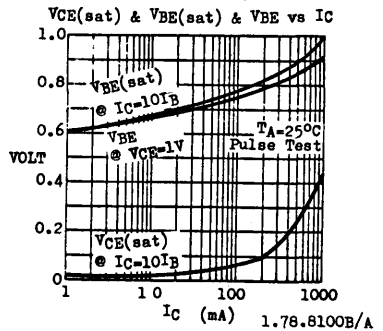
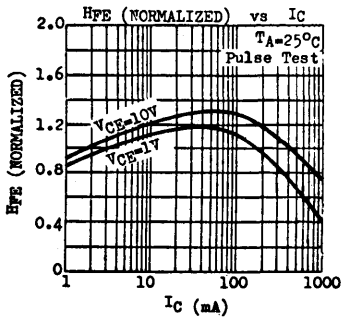
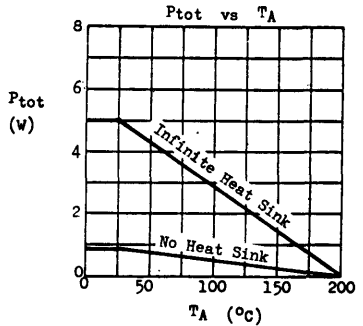
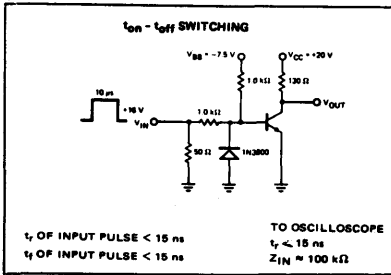

2N3563 2N5130 2N5132
PN3563 PN5130 PN5132

NPN SILICON RF SMALL SIGNAL TRANSISTORS

THE ABOVE TYPES ARE NPN SILICON PLANAR
EPITAXIAL TRANSISTORS FOR RF SMALL SIGNAL
APPLICATIONS.

CASE TO-106

CASE TO-92A

2N/PN3563 ————— $f_T = 600\text{MHz min}$
2N/PN5130 ————— $f_T = 450\text{MHz min}$
2N/PN5132 ————— $f_T = 200\text{MHz min}$



ABSOLUTE MAXIMUM RATINGS

		2N3563 2N5130	2N5132	PN3563 PN5130	PN5132
Collector-Base Voltage	V _{CB0}	30V	20V	30V	20V
Collector-Emitter Voltage	V _{CE0}	12V	20V	12V	20V
Emitter-Base Voltage	V _{EB0}	2V	3V	2V	3V
Collector Current	I _C	50mA	50mA	50mA	50mA
Total Power Dissipation ($T_A \leq 25^\circ\text{C}$)	P _{tot}	200mW	200mW	250mW	250mW
Operating Junction & Storage Temperature	T _j , T _{stg}	-55 to 125°C		-55 to 150°C	

ELECTRICAL CHARACTERISTICS ($T_A=25^\circ\text{C}$ unless otherwise noted)

PARAMETER	SYMBOL	2N/PN3563	2N/PN5130	2N/PN5132	UNIT	TEST CONDITIONS
		MIN MAX	MIN MAX	MIN MAX		
Collector-Base Breakdown Voltage	V _{CB0}	30	30	20	V	I _C =0.1mA I _E =0
					V	I _C =0.01mA I _E =0
Collector-Emitter Breakdown Voltage	V _{CE0} *	12	12	20	V	I _C =3mA I _B =0
					V	I _C =10mA I _B =0
Emitter-Base Breakdown Voltage	V _{EB0}	2	2	3	V	I _E =0.01mA I _C =0
Collector Cutoff Current	I _{CB0}	50	50	50	nA	V _{CB} =15V I _E =0
					nA	V _{CB} =10V I _E =0
Collector Cutoff Current ($T_A=65^\circ\text{C}$)	I _{CB0}	5	5	5	μA	V _{CB} =15V I _E =0
					μA	V _{CB} =10V I _E =0
Collector-Emitter Saturation Voltage	V _{CE(sat)} *		0.6	0.2	V	I _C =10mA I _B =1mA
Base-Emitter Saturation Voltage	V _{BE(sat)} *		1	0.9	V	I _C =10mA I _B =1mA
Base-Emitter Voltage	V _{BE} *		1	0.9	V	I _C =10mA V _{CE} =10V
D.C. Current Gain	h _{FE} *	20 200	15 250	30 400		I _C =8mA V _{CE} =10V
						I _C =10mA V _{CE} =10V
Current Gain-Bandwidth Product	f _T	600	450	200	MHz	I _C =8mA V _{CE} =10V
					MHz	I _C =10mA V _{CE} =15V

* Pulse Test ; Pulse Width=0.3mS, Duty Cycle=1%

2N3563 2N5130 2N5132
PN3563 PN5130 PN5132

PARAMETER	SYMBOL	2N/PN3563			2N/PN5130			2N/PN5132			UNIT	TEST CONDITIONS
		MIN	TYP	MAX	MIN	TYP	MAX	MIN	TYP	MAX		
Collector-Base Capacitance	Cob	1.3	1.7		1.3	1.7		1.8	3.5		pF	V _{CB} =10V I _E =0 f=1MHz
Feedback Time Constant	Cc'rb'	8	18	25	15						pS	I _C =8mA V _{CE} =10V f=79.8MHz
	Cc'rb'	25			18			25			pS	I _C =1mA V _{CE} =5V f=31.8MHz
Available Power Gain	G _{pe}	14 17			17						dB	I _C =8mA V _{CE} =10V f=200MHz
Noise Figure	NF	4			4						dB	I _C =1mA V _{CE} =6V R _G =400Ω f=60MHz

TYPICAL CHARACTERISTICS AT T_A=25°C

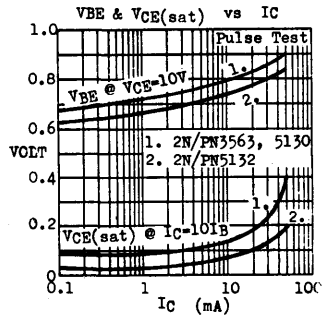
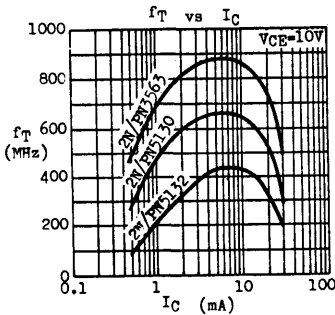
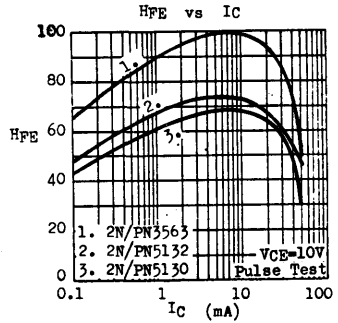
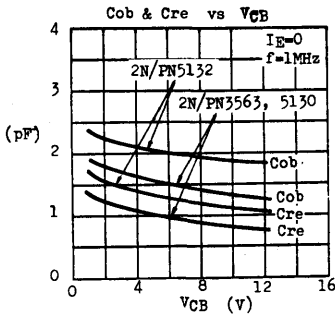

2N3565 2N5138 PN3565 PN5138

COMPLEMENTARY SILICON AF SMALL SIGNAL TRANSISTORS

THE 2N3565 (NPN) AND 2N5138 (PNP) ARE SILICON PLANAR EPITAXIAL TRANSISTORS FOR USE IN AF HIGH GAIN SMALL SIGNAL AMPLIFIER AND DIRECT COUPLED CIRCUITS. THEY ARE SUPPLIED IN CASE TO-106 AND ARE ELECTRICALLY EQUIVALENT TO THE TO-92 TYPE PN3565, PN5138.

CASE TO-106



CASE TO-92A



ABSOLUTE MAXIMUM RATINGS For p-p device, voltage and current values are negative.

		(NPN) 2N3565	(PNP) 2N5138	(NPN) PN3565	(PNP) PN5138
Collector-Base Voltage	V _{CBO}	30V	30V	30V	30V
Collector-Emitter Voltage	V _{CEO}	25V	30V	25V	30V
Emitter-Base Voltage	V _{EBO}	6V	5V	6V	5V
Collector Current	I _C	50mA	50mA	50mA	50mA
Total Power Dissipation (T _C ≤ 65°C) (T _A ≤ 25°C)	P _{tot}	300mW	300mW	750mW	750mW
		200mW	200mW	300mW	300mW
Operating Junction & Storage Temperature	T _j , T _{stg}	-55 to 125°C		-55 to 150°C	

ELECTRICAL CHARACTERISTICS (T_A = 25°C unless otherwise noted)

PARAMETER	SYMBOL	2N/PN3565		2N/PN5138		UNIT	TEST CONDITIONS
		MIN	MAX	MIN	MAX		
Collector-Base Breakdown Voltage	BV _{CBO}	30		30		V	I _C = 0.1mA I _E = 0
Collector-Emitter Breakdown Voltage	LV _{CEO}	25				V	I _C = 2mA (Pulsed) I _B = 0
				30		V	I _C = 10mA (Pulsed) I _B = 0
Emitter-Base Breakdown Voltage	BVE _{BO}	6		5		V	I _E = 0.01mA I _C = 0
Collector Cutoff Current	I _{CBO}		50			nA	V _{CB} = 25V I _E = 0
						nA	V _{CB} = 20V I _E = 0
						μA	V _{CB} = 20V I _E = 0 T _A = 65°C
Collector-Emitter Saturation Voltage	V _{CE(sat)}	0.35				V	I _C = 1mA I _B = 0.1mA
						V	I _C = 10mA I _B = 0.5mA
Base-Emitter Saturation Voltage	V _{BE(sat)}			1		V	I _C = 10mA I _B = 0.5mA
D.C. Current Gain	h _{FE}	70		50	800		I _C = 0.1mA V _{CE} = 10V
		150	600	50			I _C = 1mA V _{CE} = 10V

2N3565 2N5138 PN3565 PN5138

PARAMETER	SYMBOL	2N/PN3565		2N/PN5138		UNIT	TEST CONDITIONS
		MIN	MAX	MIN	MAX		
D.C. Current Gain	H_{FE}			50			$I_C=10mA$ $V_{CE}=10V$
Current Gain-Bandwidth Product	f_T	40	240	30			$I_C=1mA$ $V_{CE}=5V$ $I_C=0.5mA$ $V_{CE}=5V$
Small Signal Current Gain	h_{fe}	120	750	40	1000		$I_C=1mA$ $V_{CE}=10V$ $f=1kHz$
Collector-Base Capacitance	C_{ob}	4		7		pF	$V_{CB}=5V$ $I_E=0$ $f=1MHz$
Emitter-Base Capacitance	C_{ib}			30		pF	$V_{EB}=0.5V$ $I_C=0$ $f=1MHz$

TYPICAL CHARACTERISTICS ($T_A=25^\circ C$ unless otherwise noted)

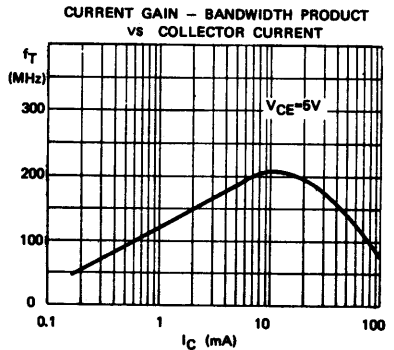
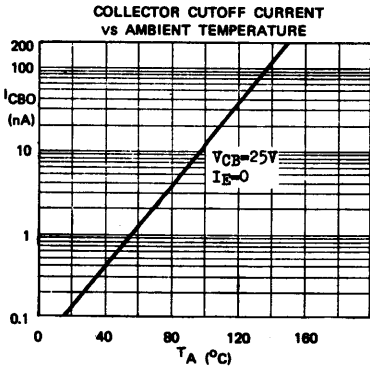
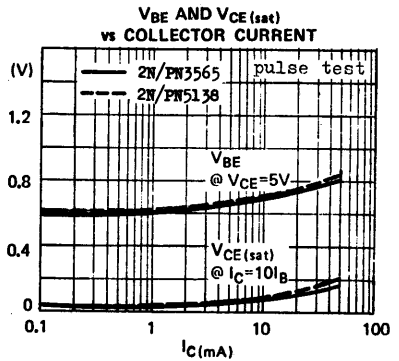
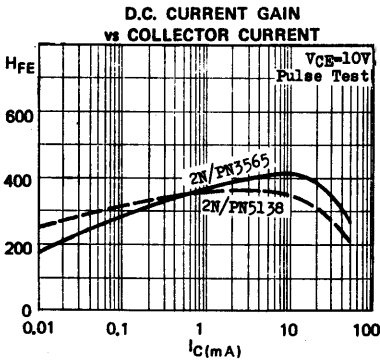

2.78.4300B.0430B

2N3691 2N3692 2N3693 2N3694

NPN SILICON TRANSISTORS

FOR SMALL SIGNAL PROCESSING APPLICATIONS

THE 2N3691 THROUGH 2N3694 ARE NPN SILICON PLANAR EPITAXIAL TRANSISTORS FOR USE IN SMALL SIGNAL PROCESSING CIRCUITS AT D.C. TO FREQUENCIES BEYOND 27MHz. THE 2N3693 IS SPECIALLY RECOMMENDED FOR VIDEO AMPLIFIER, FM-IF STAGE AND AM-CONVERTER STAGE UP TO THE SHORT WAVE BAND.

CASE TO-106



CBE

ABSOLUTE MAXIMUM RATINGS

		2N3691 <u>2N3692</u>	2N3693 <u>2N3694</u>
Collector-Base Voltage	V _{CBO}	35V	45V
Collector-Emitter Voltage	V _{CEO}	25V	45V
Emitter-Base Voltage	V _{EBO}	4V	4V
Collector Current	I _C		50mA
Total Power Dissipation (T _C ≤ 65°C)	P _{tot}		300mW
(T _A ≤ 25°C)			200mW
Operating Junction & Storage Temperature	T _j , T _{stg}		-55 to 125°C

ELECTRICAL CHARACTERISTICS (T_A=25°C unless otherwise noted)

PARAMETER	SYMBOL	MIN	TYP	MAX	UNIT	TEST CONDITIONS
Collector-Base Breakdown Voltage 2N3691,2 2N3693,4	BV _{CBO}	35 45			V V	I _C =0.1mA I _E =0
Collector-Emitter Breakdown Voltage 2N3691,2 2N3693,4	LV _{CEO}	25 45			V V	I _C =10mA (Pulsed) I _B =0
Emitter-Base Breakdown Voltage	BV _{EBO}	4			V	I _E =0.01mA I _C =0
Collector Cutoff Current 2N3691,2 2N3693,4	I _{CBO}			50 50	nA nA	V _{CB} =30V I _E =0 V _{CB} =35V I _E =0
Collector Cutoff Current 2N3691,2 2N3693,4	I _{CBO}			5 5	μA μA	V _{CB} =30V I _E =0 T _A =65°C V _{CB} =35V I _E =0 T _A =65°C
Collector-Emitter Saturation Voltage	V _{CE(sat)}	0.08	0.7		V	I _C =10mA I _B =1mA

2N3691 2N3692 2N3693 2N3694

PARAMETER	SYMBOL	MIN	TYP	MAX	UNIT	TEST CONDITIONS
Base-Emitter Saturation Voltage	$V_{BE(sat)}$		0.74	0.9	V	$I_C=10mA$ $I_B=1mA$
D.C. Current Gain	H_{FE}					
2N3691		40	80	160		$I_C=10mA$ $V_{CE}=1V$
2N3692		100	150	400		$I_C=10mA$ $V_{CE}=1V$
2N3693		40	85	160		$I_C=10mA$ $V_{CE}=10V$
2N3694		100	150	400		$I_C=10mA$ $V_{CE}=10V$
Current Gain-Bandwidth Product	f_T					
2N3691,2		200	260		MHz	$I_C=10mA$ $V_{CE}=15V$
2N3693,4		200	400		MHz	$I_C=10mA$ $V_{CE}=15V$
Collector-Base Capacitance	C_{ob}					$V_{CE}=10V$ $I_E=0$
2N3691,2			2.7	6	pF	$f=1MHz$
2N3693,4			1.8	3.5	pF	
Feedback Time Constant	$C_{c'bb'}$					$I_C=1mA$ $V_{CE}=5V$
2N3691,2				65	pS	$f=31.8MHz$
2N3693,4				23	pS	
2N3693,4 only	$C_{c'bb'}$			55	pS	$I_C=10mA$ $V_{CE}=15V$
						$f=80MHz$
Available Power Gain	G_{pe}		32		dB	$I_C=7mA$ $V_{CE}=10V$
2N3693,4 only						$f=10.7MHz$
Noise Figure	NF		4		dB	$I_C=3mA$ $V_{CE}=10V$
2N3693,4 only						$f=1MHz$ $R_G=300\Omega$

TYPICAL CHARACTERISTICS ($T_A=25^\circ C$ unless otherwise noted)

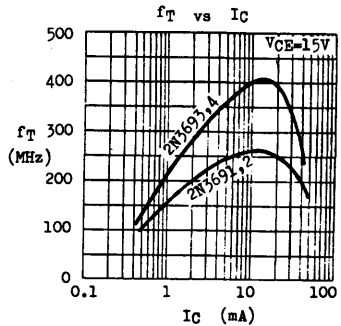
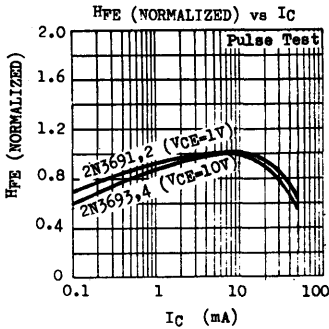

2N3691 2N3692 2N3693 2N3694

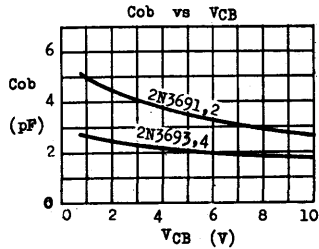
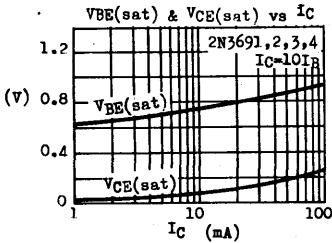

TRANSISTORS EQUIVALENT TO 2N3691,2,3,4 FAMILY

THE FOLLOWING NPN TRANSISTORS ARE SUPPLIED IN CASE TO-92B. THEIR ELECTRICAL CHARACTERISTICS ARE CLOSELY EQUIVALENT TO THE 2N3691,2,3,4 FAMILY.

CASE TO-92B



SPECIFICATIONS AT TA=25°C

	TYPE (NPN)	LVCEO (V)	hFE @ IC/VCE (mA)(V)	fT @ IC/VCE (MHz)(mA)(V)	Cob @ VCB=10V (pF) f=1MHz	Note
2N3691	2N3843, A	min	min-max	min-max	max	For Suffix "A" only NF < 8.5dB @ IC=1mA VCE=12V RC=20Ω f=2MHz
	2N3844, A	30	20-40 @ 2/4.5	60-230 @ 2/10	4	
	2N3845, A	30	35-70 @ 2/4.5	90-250 @ 2/10	4	
2N3693, 4	2N3854	18	20-40 @ 2/4.5	60-230 @ 2/10	3.5	Ccrbb' < 90pS @ IC=5mA VCE=10V f=31.6MHz
	2N3855	18	35-70 @ 2/4.5	90-250 @ 2/10		
	2N3856	18	100-200 @ 2/4.5	140-500 @ 5/10		
	2N3854A	30	60-120 @ 2/4.5	100-350 @ 5/10		
	2N3855A	30	35-70 @ 2/4.5	130-450 @ 5/10		
	2N3856A	30	60-120 @ 2/4.5	140-500 @ 5/10		
2N3692	2N3858		60-120 @ 2/4.5	90-250 @ 2/10	4	Ccrbb' < 150pS @ IC=2mA VCE=10V f=2MHz
	2N3859	30	100-200 @ 2/4.5	90-250 @ 2/10		
	2N3860	30	150-300 @ 2/4.5	90-250 @ 2/10		
	2N5232, A	50	250-500 @ 2/5			

2.78.4300A.3300A.4300A/B

* NF @ IC=0.1mA VCE=5V
RC=5KΩ f=30Hz-15KHz

2N3702 through 2N3706 MPS3702 through MPS3706

PNP NPN SILICON GENERAL PURPOSE AF TRANSISTORS

THE ABOVE TYPES ARE SILICON PLANAR EPITAXIAL TRANSISTORS FOR GENERAL PURPOSE AF MEDIUM POWER APPLICATIONS. THE 2N3702 SERIES ARE SUPPLIED IN CASE TO-92B. THE MPS3702 SERIES ARE SUPPLIED IN CASE TO-92A.

CASE TO-92B



ECB

CASE TO-92A



EBC

		(PNP)	(PNP)	(NPN)	(NPN)
		2N/MPS3702	2N/MPS3703	2N/MPS3704	2N/MPS3706
ABSOLUTE MAXIMUM RATINGS					
Collector-Base Voltage	V _{CB0}	40V	50V	50V	40V
Collector-Emitter Voltage	V _{CE0}	25V	30V	30V	20V
Emitter-Base Voltage	V _{EB0}	5V	5V	5V	5V
Collector Current	I _C	0.2A	0.2A	0.8A	0.8A
Collector Peak Current	I _{CM}	0.6A	0.6A		
Total Power Dissipation (T _C ≤ 25°C)	P _{tot}			1W	
				360mW	
Operating Junction & Storage Temperature	T _j , T _{stg}			-55 to 150°C	

ELECTRICAL CHARACTERISTICS (T_A=25°C unless otherwise noted)

PARAMETER	SYMBOL	MIN	TYP	MAX	UNIT	TEST CONDITIONS
Collector-Base Breakdown Voltage	V _{CB0}	↑			V	I _C =0.1mA I _E =0
Collector-Emitter Breakdown Voltage	V _{CE0} *	Note 1			V	I _C =10mA I _B =0
Emitter-Base Breakdown Voltage	V _{EB0}	↓			V	I _E =0.1mA I _C =0
Collector Cutoff Current	I _{CB0}			100	nA	V _{CB} =20V I _E =0
Emitter Cutoff Current	I _{EB0}			100	nA	V _{EB} =3V I _C =0
Collector-Emitter Saturation Voltage	V _{CE(sat)} *				V	
2N/MPS3702,3			0.1	0.25	V	I _C =50mA I _B =5mA
2N/MPS3704			0.12	0.6	V	I _C =100mA I _B =5mA
2N/MPS3705			0.15	0.8	V	I _C =100mA I _B =5mA
2N/MPS3706			0.15	1	V	I _C =100mA I _B =5mA
Base-Emitter Voltage	V _{BE} *				V	
2N/MPS3702,3		0.6	0.78	1	V	I _C =50mA V _{CE} =5V
2N/MPS3704,5,6		0.5	0.83	1	V	I _C =100mA V _{CE} =2V
D.C. Current Gain	h _{FE} *					
2N/MPS3702			60	300		I _C =50mA V _{CE} =5V
2N/MPS3703			30	150		I _C =50mA V _{CE} =5V
2N/MPS3704			100	300		I _C =50mA V _{CE} =2V

For p-n-p devices, voltage and current values are negative.

2N3702 through 2N3706 MPS3702 through MPS3706

PARAMETER	SYMBOL	MIN	TYP	MAX	UNIT	TEST CONDITIONS
D.C. Current Gain	$H_{FE} *$	50	150	600		$I_C=50mA$ $V_{CE}=2V$ $I_C=50mA$ $V_{CE}=2V$
Current Gain-Bandwidth Product	f_T	100			MHz	$I_C=50mA$ $V_{CE}=5V$ $I_C=50mA$ $V_{CE}=2V$
Collector-Base Capacitance	C_{ob}		5	12	pF	$V_{CB}=10V$ $I_E=0$ $f=1MHz$
			4	12	pF	

Note 1 : equal to the values of absolute maximum ratings.

* Pulse Test : Pulse Width=0.3ms, Duty Cycle=1%

TYPICAL CHARACTERISTICS ($T_A=25^\circ C$ unless otherwise noted)

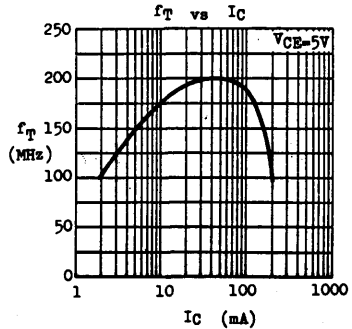
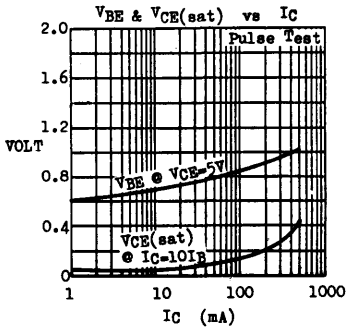
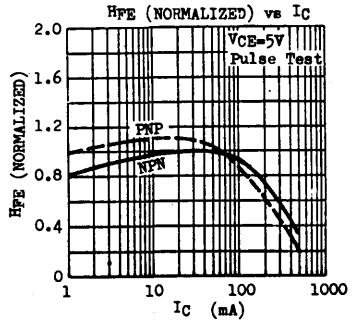
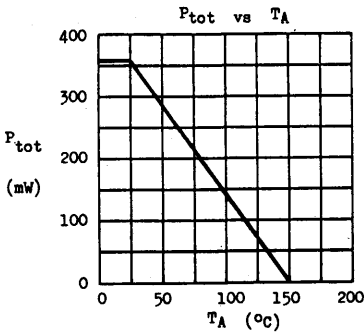

TRANSISTORS EQUIVALENT TO 2N/MFS3702 FAMILY

THE FOLLOWING TRANSISTORS, WHICH ARE CLOSELY EQUIVALENT TO THE 2N/MFS3702 FAMILY, ARE ALSO AVAILABLE.

TO-92B

TO-92A

WITH X-67 HEAT SINK

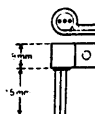

SPECIFICATIONS AT $T_A=25^{\circ}\text{C}$

For p-n-p devices, voltage and current values are negative.

TYPE	POLARITY	CASE (P_{tot})	V_{CE0} (V)	V_{BE0} (V)	$I_{C0} @ V_{CE}$ (μA)	V_{CE} (V)	$h_{FE} @ I_C/V_{CE}$ (mA) (V)	$V_{CE(sat)} @ I_C/I_B$ (V) (mA)(mA)	$f_T @ I_C$ (MHz)(mA)
			min	min	max	min-max	max	min	
2N3402	NPN	TO-92B with X-67 Heat Sink (560mW)	25	5	0.1 @ 25	75-225 @ 2/4.5	0.3 @ 50/3		
2N3403			25	5	0.1 @ 25	180-540 @ 2/4.5	0.3 @ 50/3		
2N3404			50	5	0.1 @ 50	75-225 @ 2/4.5	0.3 @ 50/3		
2N3405			50	5	0.1 @ 50	180-540 @ 2/4.5	0.3 @ 50/3		
2N4425			40	5	*0.03 @ 40	180-540 @ 2/4.5	0.3 @ 50/3		
2N3414	NPN	TO-92B (360mW)	25	5	0.1 @ 25	75-225 @ 2/4.5	0.3 @ 50/3		
2N3415			25	5	0.1 @ 25	180-540 @ 2/4.5	0.3 @ 50/3		
2N3416			50	5	0.1 @ 50	75-225 @ 2/4.5	0.3 @ 50/3		
2N3417			50	5	0.1 @ 50	180-540 @ 2/4.5	0.3 @ 50/3		
2N4424			40	5	*0.03 @ 40	180-540 @ 2/4.5	0.3 @ 50/3		
2N5220	NPN	TO-92A (350mW)	15	3	0.1 @ 10	25- @ 10/10 30-600 @ 50/10	0.5 @ 150/15	100 @ 20	
2N5221	PNP		15	3	0.1 @ 10	25- @ 10/10 30-600 @ 50/10	0.5 @ 150/15	100 @ 20	
2N5225	NPN		25	4	0.3 @ 15	25- @ 10/10 30-600 @ 50/10	0.8 @ 100/10	50 @ 20	
2N5226	PNP		25	4	0.3 @ 15	25- @ 10/10 30-600 @ 50/10	0.8 @ 100/10	50 @ 20	
2N5354	PNP	TO-92B (360mW)	25	4	*0.1 @ 25	40-120 @ 50/1 20- @ 300/5	0.25 @ 50/2.5 1.0 @ 300/30		
2N5355	PNP		25	4	*0.1 @ 25	100-300 @ 50/1 40- @ 300/5			
2N5356	PNP		25	4	*0.1 @ 25	250-500 @ 50/1 75- @ 300/5			
2N5365	PNP	TO-92B (360mW)	40	4	*0.1 @ 40	40-120 @ 50/1 20- @ 300/5	0.25 @ 50/2.5 1.0 @ 300/30		
2N5366	PNP		40	4	*0.1 @ 40	100-300 @ 50/1 40- @ 300/5			
2N5367	PNP		40	4	*0.1 @ 40	250-500 @ 50/1 75- @ 300/5			

* I_{CES}

2.78.6500B.0650B

TRANSISTORS EQUIVALENT TO 2N/MFS3702 FAMILY

TYPE	POLARITY	CASE (P _{tot})	LVCE0 (V)	BVEBO (V)	ICES @ VCE (μ A) (V)	HFE @ IC/VCE (mA)(V)	VCE(sat) @ IC/IB (V) (mA)(mA)	f _T @ IC (MHz)(mA)
			min	min	max	min-max	max	min
2N5418	NPN	TO-92B (400mW)	25	4	0.1 @ 25	40-120 @ 50/1 20- @ 300/5	0.25 @ 50/2.5 1.0 @ 300/30	
2N5419	NPN		25	4	0.1 @ 25	100-300 @ 50/1 40- @ 300/5		
2N5420	NPN		25	4	0.1 @ 25	250-500 @ 50/1 75- @ 300/5		
2N5447	PNP	These are TO-92F transistors. Their electrical characteristics are exactly identical to 2N3702, 3, 4, 5, 6 respectively.						
2N5448	PNP							
2N5449	NPN							
2N5450	NPN							
2N5451	NPN							

2.78.6500B.0650B

2N3707 through 2N3711 2N4058 through 2N4062

NPN PNP SILICON AF SMALL SIGNAL TRANSISTORS

THE 2N3707 THROUGH 2N3711 (NPN) AND 2N4058 THROUGH 2N4062 (PNP) ARE COMPLEMENTARY SILICON PLANAR EPITAXIAL TRANSISTORS FOR USE IN AF SMALL SIGNAL AMPLIFIER STAGES AND DIRECT COUPLED CIRCUITS.

CASE TO-92B



ECB

<u>ABSOLUTE MAXIMUM RATINGS</u>		(NPN)		(PNP)	
<small>For n-p-n devices, voltage and current values are negative</small>		2N3707	thru' 2N3711	2N4058	thru' 2N4062
Collector-Base Voltage	V _{CB0}	30V		30V	
Collector-Emitter Voltage	V _{CE0}	30V		30V	
Emitter-Base Voltage	V _{EB0}	6V		6V	
Collector Current	I _C	200mA		100mA **	
Total Power Dissipation (T _A ≤ 25°C)	P _{tot}	360mW		derate 2.88mW/°C above 25°C	
Operating Junction & Storage Temperature T _J , T _{stg}		-55 to 150°C			

** 30mA in JEDEC registration.

ELECTRICAL CHARACTERISTICS (T_A=25°C unless otherwise noted)

PARAMETER	SYMBOL	NPN		PNP		UNIT	TEST CONDITIONS
		MIN	MAX	MIN	MAX		
Collector-Base Breakdown Voltage	BV _{CB0}	30		30		V	I _C =0.01mA I _E =0
Collector-Emitter Breakdown Voltage	LV _{CE0}	30		30		V	I _C =1mA I _B =0 (Pulsed)
Collector Cutoff Current	ICBO		100		100	nA	V _{CB} =20V I _E =0
Emitter Cutoff Current	IEBO		100		100	nA	V _{EB} =6V I _C =0
Collector-Emitter Saturation Voltage	V _{CE(sat)}		1		0.7	V	I _C =10mA I _B =0.5mA
Base-Emitter Voltage	V _{BE}	0.5	1	0.5	1	V	I _C =1mA V _{CE} =5V
Noise Figure *	NF				5	dB	I _C =0.1mA V _{CE} =5V R _G =5KΩ f=30Hz-15KHz
					5	dB	I _C =0.1mA V _{CE} =5V R _G =10KΩ f=30Hz-15KHz

* For 2N3707 and 2N4058 only.

2N3707 through 2N3711 2N4058 through 2N4062

D.C. AND SMALL SIGNAL CURRENT GAIN (H_{FE} , h_{fe}) AT $V_{CE}=5V$ $T_A=25^\circ C$

PARAMETER	2N3707		2N3708		2N3709		2N3710		2N3711	
	2N4058		2N4059		2N4060		2N4061		2N4062	
	MIN	MAX	MIN	MAX	MIN	MAX	MIN	MAX	MIN	MAX
H_{FE} at $I_C=0.1mA$	100	400								
H_{FE} at $I_C=1mA$			45	660	45	165	90	330	180	660
h_{fe} at $I_C=0.1mA$ $f=1KHz$	100	550								
h_{fe} at $I_C=1mA$ $f=1KHz$			45	800	45	250	90	450	180	800

TYPICAL CHARACTERISTICS AT $T_A=25^\circ C$

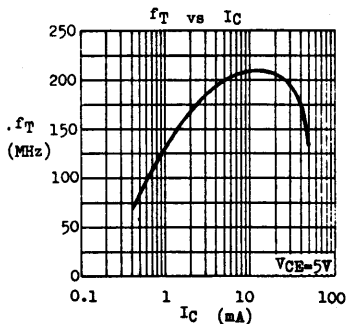
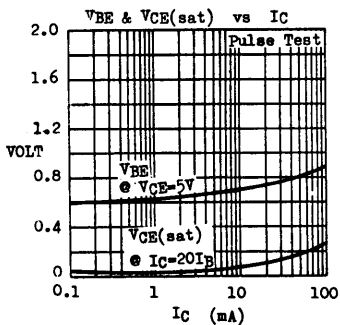
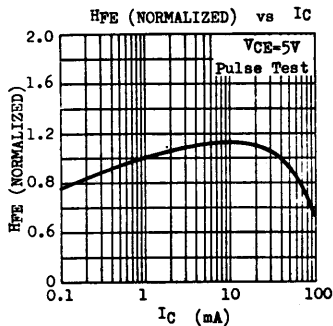
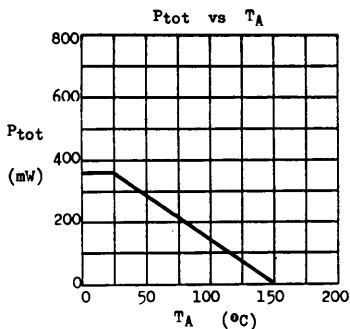

2.78.4300B.0430B

2N3823

N-CHANNEL JUNCTION FIELD EFFECT TRANSISTORS

THE 2N3823 IS AN N-CHANNEL JFET DESIGNED FOR RF AMPLIFIER AND MIXER APPLICATIONS. IT FEATURES LOW CROSS-MODULATION, LOW NOISE FIGURE AND GOOD POWER GAIN AT FREQUENCY UP TO 450MHz. THE DEVICE IS ALSO SUITABLE FOR ANALOG SWITCHING WHERE LOW JUNCTION CAPACITANCE IS ESSENTIAL.

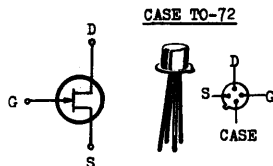

THE S, D, G TERMINALS ARE ELECTRICALLY ISOLATED FROM CASE.

ABSOLUTE MAXIMUM RATINGS

Drain-Gate Voltage	V _{DG}	30V
Drain-Source Voltage	V _{DS}	30V
Gate-Source Voltage	V _{GS}	-30V
Gate Current	I _G	10mA
Total Power Dissipation (T _A ≤ 25°C)	P _{tot}	300mW derate 2mW/°C above 25°C
Operating Junction & Storage Temperature	T _j , T _{stg}	-65 to 175°C

ELECTRICAL CHARACTERISTICS (T_A=25°C unless otherwise noted)

* Common Source

PARAMETER	SYMBOL	MIN	TYP	MAX	UNIT	TEST CONDITIONS
Gate-Source Breakdown Voltage	-BV _{GS}	30			V	-I _G =1μA V _{DS} =0
Gate Cutoff Current	-I _{GSS}		0.5	0.5	nA μA	-V _{GS} =20V V _{DS} =0 -V _{GS} =20V V _{DS} =0 T _A =150°C
Zero-Gate-Voltage Drain Current	I _{DSS}	4	10	20	mA	V _{DS} =15V V _{GS} =0
Gate Source Voltage	-V _{GS}	1	3.2	7.5	V	V _{DS} =15V I _D =0.4mA
Gate Source Cutoff Voltage	-V _{GS(off)}		3.5	8	V	V _{DS} =15V I _D =0.5nA
Forward Transfer Admittance	Y _{fs} *	3.5	5	6.5	mS	V _{DS} =15V V _{GS} =0 f=1kHz
Output Admittance	Y _{os} *		20	35	μS	V _{DS} =15V V _{GS} =0 f=1kHz
Input Capacitance	C _{iss} *		3.5	6	pF	V _{DS} =15V V _{GS} =0 f=1MHz
Feedback Capacitance	C _{rss} *		0.7	2	pF	V _{DS} =15V V _{GS} =0 f=1MHz

PARAMETER	SYMBOL	MIN	TYP	MAX	UNIT	TEST CONDITIONS
Forward Transfer Admittance	$ y_{fs} $ *	3.2	5.5		m μ	$V_{DS}=15V$ $V_{GS}=0$ $f=200MHz$
Input Conductance	g_{is} *		250	800	μ U	$V_{DS}=15V$ $V_{GS}=0$ $f=200MHz$
Output Conductance	g_{os} *		60	200	μ U	$V_{DS}=15V$ $V_{GS}=0$ $f=200MHz$
Spot Noise Figure	NF *		1	2.5	dB	$V_{DS}=15V$ $V_{GS}=0$ $f=100MHz$ $R_G=1K\Omega$
Power Gain	G_{ps} *		12		dB	$V_{DS}=15V$ $I_D=5mA$ $f=400MHz$
Equivalent Noise Input Voltage	\bar{E}_n *		8		nV/ \sqrt{Hz}	$V_{DS}=15V$ $I_D=1mA$ $f=100Hz$
"On" Resistance	$r_{ds(on)}$		170		Ω	$V_{DS}=100mV$ $V_{GS}=0$

TYPICAL COMMON SOURCE y-PARAMETER AT $V_{DS}=15V$ $V_{GS}=0$ $T_A=25^\circ C$

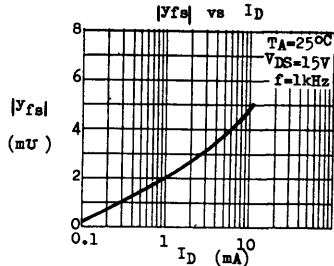
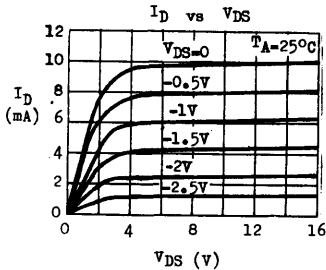
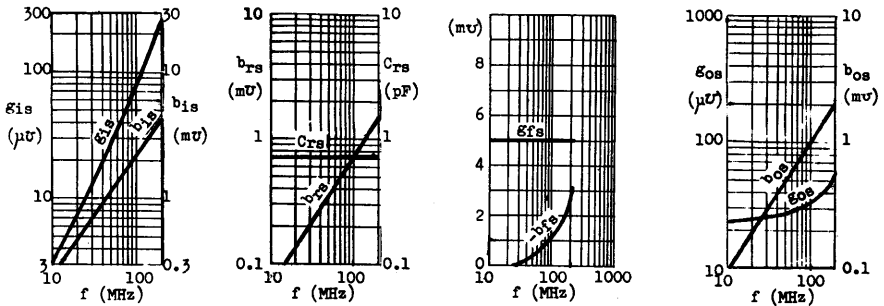

2N3823 & similar types

2N3823 AND SIMILAR TYPES — SPECIFICATIONS AT $T_A=25^\circ\text{C}$

TYPE	CASE	$V_{GS} \text{ @ } I_D$ (V) (μA) min		① $V_{DS}=15V$		② $V_{DS}=15V$ $V_{GS}=0$				
				$-V_{GS}(\text{off})$ ③ I_D		I_{DSS} (mA) min-max	④ $f=1\text{kHz}$		⑤ $f=1\text{MHz}$	
				(V) min-max	(nA)		$ f_{\beta} $ (mΩ)	$ f_{os} $ (μΩ)	C_{iss} (pF)	C_{rss} (pF)
BF244A BF244B BF244C	TO-92DA	30	1	0.5-8	10	2-6.5 6-15 12-25	3-6.5			
BF245A BF245B BF245C	TO-92DE	30	1	0.5-8	10	2-6.5 6-15 12-25	3-6.5			
BF256A BF256B BF256C	TO-92DE	30	1	0.5-7.5	200μA	3-7 6-13 11-18	4.5-			
2N3819	TO-92DA	25	1	-8	2	2-20	2-6.5	50	8	4
2N3823	TO-72	30	1	-8	0.5	4-20	3.5-6.5	35	6	2
2N4302* 2N4303* 2N4304*	TO-106	30	1	-4 -6 -10	10 10 10	0.5-5 4-10 0.5-15	1- 2- 1-	50	6	3
2N4416	TO-72	30	1	-6	1	5-15	4.5-7.5	50	4	0.8
2N5103 2N5104	TO-72	25 25	10 1	0.5-4	1	1-8 2-6	2-8 3.5-7.5	100	5	1
2N5163	TO-106	25	1	0.4-8	1μA	1-40	2-9	200	12	3
2N5245 2N5246 2N5247	TO-92DE	30	1	1-6 0.5-4 1.5-8	10 10 10	5-15 1.5-7 8-24	4.5-7.5 3-6 4.5-8	50 50 70	4.5	1
2N5248	TO-92DA	30	1	1-8	10	4-20	3.5-6.5	50	6	2
2N5457 2N5458 2N5459	TO-92DD	25	10	0.5-6 1-7 2-8	10 10 10	1-5 2-9 4-16	1-5 1.5-5.5 2-6	50	7	3
2N5484 2N5485 2N5486	TO-92DD	25	1	0.3-3 0.5-4 2-6	10 10 10	1-5 4-10 8-20	3-6 3.5-7 4-8	50 60 75	5	1
2N5556 2N5557 2N5558	TO-72	30	10	0.2-4 0.8-5 1.5-6	1 1 1	0.5-2.5 2-5 4-10	1.5-6.5	20	6	3
2N5668 2N5669 2N5670	TO-92DD	25	10	0.2-4 1-6 2-8	10 10 10	1-5 4-10 8-20	1.5-6.5 2-6.5 3-7.5	20 50 75	7	3

* $V_{GS}(\text{off})$, I_{DSS} , y_{fe} , y_{os} , C_{iss} and C_{rss} are tested @ $V_{DS}=20V$

2N3823 & similar types

JFET LEAD CODE

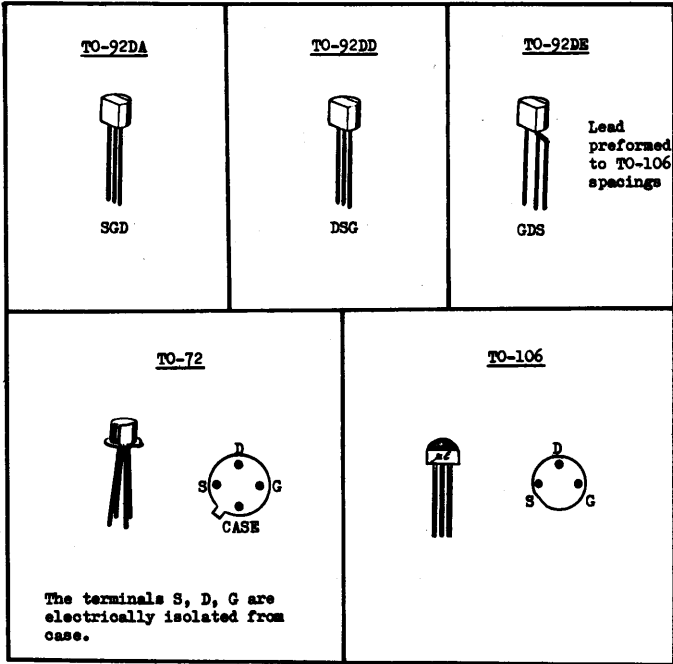

2N3825 2N3827

NPN SILICON RF SMALL SIGNAL TRANSISTORS

THE 2N3825, 2N3827 ARE NPN SILICON PLANAR EPITAXIAL TRANSISTORS FOR RF AND IF SMALL SIGNAL AMPLIFIER APPLICATIONS.

2N3825 — $f_T = 550\text{MHz typ. @ } I_C = 2\text{mA}$
 2N3827 — $f_T = 350\text{MHz typ. @ } I_C = 2\text{mA}$

CASE TO-92B



ABSOLUTE MAXIMUM RATINGS

		2N3825	2N3827
Collector-Base Voltage	V _{CB0}	30V	60V
Collector-Emitter Voltage	V _{CE0}	15V	45V
Emitter-Base Voltage	V _{EB0}	4V	4V
Collector Current	I _C	50mA	
Total Power Dissipation ($T_A \leq 25^\circ\text{C}$)	P _{tot}	250mW	
Operating Junction & Storage Temperature	T _j , T _{stg}	-55 to 150°C	

ELECTRICAL CHARACTERISTICS (T_A=25°C)

PARAMETER	SYMBOL	2N3825		2N3827		UNIT	TEST CONDITIONS
		MIN	MAX	MIN	MAX		
Collector-Base Breakdown Voltage	V _{CB0}	30		60		V	I _C =0.01mA I _E =0
Collector-Emitter Breakdown Voltage	V _{CE0}	15		45		V	I _C =1mA (Pulsed) I _B =0
Emitter-Base Breakdown Voltage	V _{EB0}	4		4		V	I _E =0.01mA I _C =0
Collector Cutoff Current	I _{CB0}		100		100	nA nA	V _{CB} =15V I _E =0 V _{CB} =30V I _E =0
Collector-Emitter Saturation Voltage	V _{CE(sat)}		0.25			V	I _C =2mA I _B =0.2mA
D.C. Current Gain	h _{FE}	20		100	400		I _C =2mA V _{CE} =10V I _C =10mA V _{CE} =10V
Current Gain-Bandwidth Product	f _T	200	800	200	800	MHz MHz	I _C =2mA V _{CE} =10V I _C =10mA V _{CE} =10V
Collector-Base Capacitance	C _{ob}		3.5		3.5	pF	V _{CB} =10V I _E =0 f=1MHz
Noise Figure	NF		5.5			dB	I _C =1mA V _{CE} =5V R _G =50Ω f=1MHz

2N3825 2N3827

TYPICAL CHARACTERISTICS AT TA=25°C

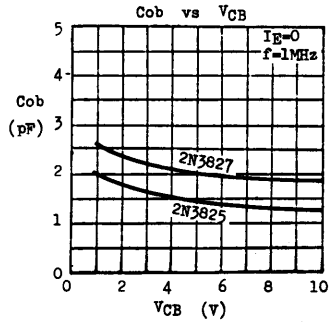
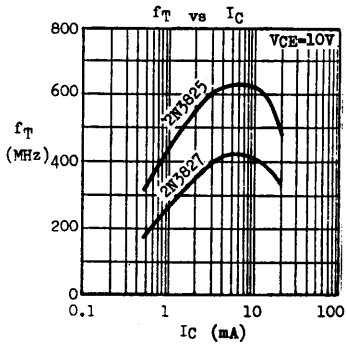
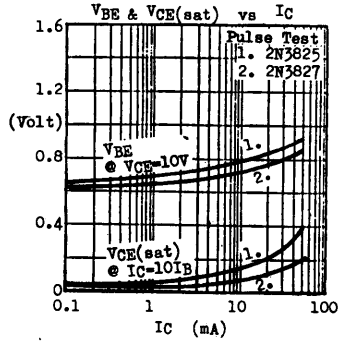
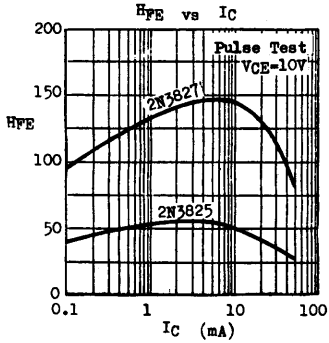

2N4030 through 2N4033

PNP SILICON AF MEDIUM POWER AMPLIFIERS & SWITCHES

THE 2N4030 THROUGH 2N4033 ARE PNP SILICON PLANAR EPITAXIAL TRANSISTORS FOR AF MEDIUM POWER DRIVERS AND OUTPUTS, AS WELL AS FOR SWITCHING APPLICATIONS UP TO 1 AMPERE. THE 2N4030, 2N4031, 2N4032, 2N4033 ARE COMPLEMENTARY TO THE NPN 2N3108, 2N3020, 2N3107, 2N3019 RESPECTIVELY.

CASE TO-39



C E B

ABSOLUTE MAXIMUM RATINGS

		2N4030 2N4032	2N4031 2N4033
Collector-Base Voltage	-V _{CB0}	60V	80V
Collector-Emitter Voltage	-V _{CE0}	60V	80V
Emitter-Base Voltage	-V _{EB0}	5V	5V
Collector Current	-I _C		1A
Total Power Dissipation (T _C ≤ 25°C) (T _A ≤ 25°C)	P _{tot}		4W 800mW
Operating Junction & Storage Temperature	T _j , T _{stg}	-65 to 200°C	

ELECTRICAL CHARACTERISTICS (T_A=25°C unless otherwise noted)

PARAMETER	SYMBOL	MIN	MAX	UNIT	TEST CONDITIONS
Collector-Base Breakdown Voltage 2N4030, 2N4032 2N4031, 2N4033	-V _{CB0}	60		V	-I _C =0.01mA I _E =0
		80		V	
Collector-Emitter Breakdown Voltage 2N4030, 2N4032 2N4031, 2N4033	-V _{CE0} *	60		V	-I _C =10mA I _B =0
		80		V	
Emitter-Base Breakdown Voltage	-V _{EB0}	5		V	-I _E =0.01mA I _C =0
Collector Cutoff Current 2N4030, 2N4032 2N4031, 2N4033	-I _{CB0}		50	nA	-V _{CB} =50V I _E =0
			50	nA	-V _{CB} =60V I _E =0
Collector Cutoff Current 2N4030, 2N4032 2N4031, 2N4033	-I _{CB0}		50	μA	-V _{CB} =50V I _E =0 T _A =150°C
			50	μA	-V _{CB} =60V I _E =0 T _A =150°C
Collector-Emitter Saturation Voltage 2N4030, 2N4032 only	-V _{CE(sat)} *	0.15		V	-I _C =150mA -I _B =15mA
		0.5		V	-I _C =500mA -I _B =50mA
		1.0		V	-I _C =1A -I _B =0.1A
Base-Emitter Saturation Voltage	-V _{BE(sat)} *	0.9		V	-I _C =150mA -I _B =15mA
Base-Emitter Voltage 2N4030, 2N4032 only	-V _{BE} *	1.1		V	-I _C =500mA -V _{CE} =0.5V
		1.2		V	-I _C =1A -V _{CE} =1V

2N4030 through 2N4033

PARAMETER	SYMBOL	MIN	MAX	UNIT	TEST CONDITIONS
D.C. Current Gain 2N4030, 2N4031 only	HFE *	30	120		-I _C =0.1mA -V _{CE} =5V
		40			-I _C =100mA -V _{CE} =5V
		25			-I _C =500mA -V _{CE} =5V
D.C. Current Gain 2N4032, 2N4033 only	HFE *	75	300		-I _C =0.1mA -V _{CE} =5V
		100			-I _C =100mA -V _{CE} =5V
		70			-I _C =500mA -V _{CE} =5V
D.C. Current Gain 2N4030 2N4031 2N4032 2N4033	HFE *	15			-I _C =1A -V _{CE} =5V
		10			
		40			
		25			
D.C. Current Gain 2N4030, 2N4031 2N4032, 2N4033	HFE *	15	40		-I _C =100mA -V _{CE} =5V T _A =-55°C
		40			
Current Gain-Bandwidth Product 2N4030, 2N4031 2N4032, 2N4033	f _T	100	400	MHz	-I _C =50mA -V _{CE} =10V
		150	500	MHz	
Collector-Base Capacitance	C _{ob}		20	pF	-V _{CB} =10V I _B =0 f=1MHz
Emitter-Base Capacitance	C _{ib}		110	pF	-V _{EB} =0.5V I _C =0 f=1MHz
Turn-On Time	t _{on}		100	nS	-I _C =500mA -I _{B1} =50mA
Storage Time	t _s		350	nS	-I _C =500mA -I _{B1} =I _{B2} =50mA
Full Time	t _f		50	nS	-I _C =500mA -I _{B1} =I _{B2} =50mA

* Pulse Test : Pulse Width=0.3ms, Duty Cycle=1%

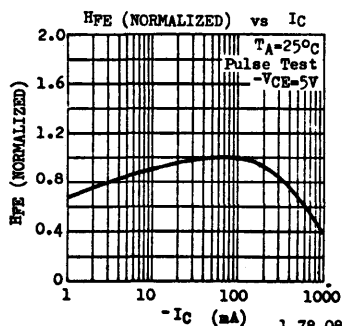
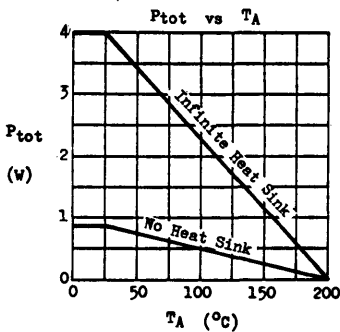
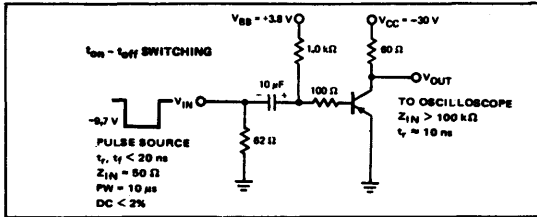

1.78.0810B

2N4234 2N4235 2N4237 2N4238

COMPLEMENTARY SILICON AF MEDIUM POWER AMPLIFIERS & SWITCHES

THE 2N4234, 2N4235 (PNP) AND 2N4237, 2N4238 (NPN) ARE COMPLEMENTARY SILICON PLANAR EPITAXIAL TRANSISTORS FOR USE IN AF MEDIUM POWER DRIVERS AND OUTPUTS, AS WELL AS FOR SWITCHING APPLICATIONS ABOVE 1 AMPERE. THEY FEATURE LOW COLLECTOR-EMITTER SATURATION VOLTAGE (0.6V MAX @ $I_C=1A$).

CASE TO-39



ABSOLUTE MAXIMUM RATINGS

For p-n-p devices, voltage and current values are negative.

		(PNP) 2N4234	(PNP) 2N4235	(NPN) 2N4237	(NPN) 2N4238
Collector-Base Voltage	V_{CBO}	40V	60V	50V	80V
Collector-Emitter Voltage	V_{CEO}	40V	60V	40V	60V
Emitter-Base Voltage	V_{EBO}	7V	7V	6V	6V
Collector Current	I_C	3A	3A	3A**	3A**
Total Power Dissipation ($T_C \leq 25^\circ C$) ($T_A \leq 25^\circ C$)	P_{tot}	$\leftarrow 6W$, derate $34mW/^\circ C$ above $25^\circ C$ $\leftarrow 1W$, derate $5.7mW/^\circ C$ above $25^\circ C$			
Operating Junction & Storage Temperature	T_j, T_{stg}	-65 to $200^\circ C$			

** 1A in JEDEC Registration

ELECTRICAL CHARACTERISTICS ($T_A=25^\circ C$ unless otherwise noted)

PARAMETER	SYMBOL	MIN	TYP	MAX	UNIT	TEST CONDITIONS
Collector-Emitter Breakdown Voltage 2N4234, 2N4237 2N4235, 2N4238	$V_{V_{CEO}}$ *	40		60	V	$I_C=100mA$ $I_E=0$
Collector Cutoff Current 2N4234 2N4235 2N4237 2N4238	I_{CEV}		0.1		mA	$V_{CE}=40V$ $V_{EB}=1.5V$ $V_{CE}=60V$ $V_{EB}=1.5V$ $V_{CE}=45V$ $V_{EB}=1.5V$ $V_{CE}=75V$ $V_{EB}=1.5V$
Collector Cutoff Current 2N4234 2N4235 2N4237 2N4238	I_{CEV}		1		mA	$V_{CE}=30V$ $V_{EB}=1.5V$ $T_A=150^\circ C$ $V_{CE}=40V$ $V_{EB}=1.5V$ $T_A=150^\circ C$ $V_{CE}=30V$ $V_{EB}=1.5V$ $T_A=150^\circ C$ $V_{CE}=50V$ $V_{EB}=1.5V$ $T_A=150^\circ C$
Collector Cutoff Current	I_{CBO}		0.1		mA	$V_{CB}=V_{CBO}$ $I_E=0$

2N4234 2N4235 2N4237 2N4238

PARAMETER	SYMBOL	MIN	TYP	MAX	UNIT	TEST CONDITIONS
Collector Cutoff Current 2N4234 2N4235 2N4237 2N4238	I_{CBO}			1 1 0.7 0.7	mA	$V_{CE}=30V$ $I_B=0$ $V_{CE}=40V$ $I_B=0$ $V_{CE}=40V$ $I_B=0$ $V_{CE}=60V$ $I_B=0$
Emitter Cutoff Current	I_{EBO}			0.5	mA	$V_{EB}=V_{EBO}$ $I_C=0$
Collector-Emitter Saturation Voltage 2N4234, 2N4235 only	$V_{CE(sat)}^*$	0.35	0.6		V	$I_C=1A$ $I_B=125mA$
Collector-Emitter Saturation Voltage 2N4237, 2N4238 only	$V_{CE(sat)}^*$	0.18	0.3	0.35	V	$I_C=500mA$ $I_B=50mA$ $I_C=1A$ $I_B=0.1A$
Base-Emitter Saturation Voltage	$V_{BE(sat)}^*$	1.0	1.5		V	$I_C=1A$ $I_B=0.1A$
Base-Emitter Voltage	V_{BE}^*	0.78	1.0		V	$I_C=250mA$ $V_{CE}=1V$
D.C. Current Gain 2N4234, 2N4235 only	H_{FE}^*	40 30 20 10		150		$I_C=100mA$ $V_{CE}=1V$ $I_C=250mA$ $V_{CE}=1V$ $I_C=500mA$ $V_{CE}=1V$ $I_C=1A$ $V_{CE}=1V$
D.C. Current Gain 2N4237, 2N4238 only	H_{FE}^*	30 30 30 15		150		$I_C=50mA$ $V_{CE}=1V$ $I_C=250mA$ $V_{CE}=1V$ $I_C=500mA$ $V_{CE}=1V$ $I_C=1A$ $V_{CE}=1V$
Current Gain-Bandwidth Product 2N4234, 2N4235 2N4237, 2N4238	f_T	3 2	70 70		MHz	$I_C=100mA$ $V_{CE}=10V$ $I_C=100mA$ $V_{CE}=10V$
Collector-Base Capacitance	C_{ob}			100	pF	$V_{CB}=10V$ $I_E=0$ $f=100kHz$
Small Signal Current Gain 2N4234, 2N4235 2N4237, 2N4238	h_{fe}	25 30				$I_C=50mA$ $V_{CE}=10V$ $f=1kHz$ $I_C=100mA$ $V_{CE}=10V$ $f=1kHz$

* Pulse Test : Pulse Width=0.3mS, Duty Cycle=1%

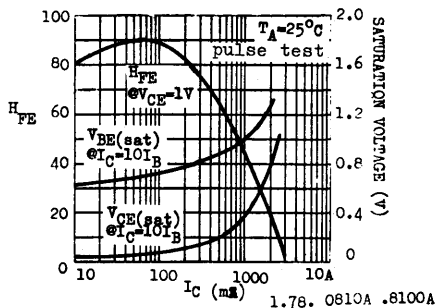
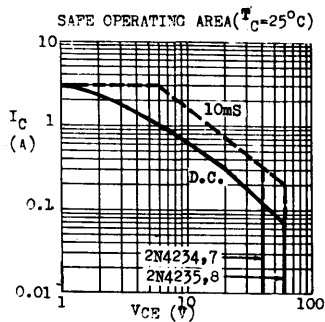

2N4248 2N4249 2N4250

PNP SILICON AF LOW NOISE SMALL SIGNAL TRANSISTORS

THE 2N4248, 2N4249, 2N4250 ARE PNP SILICON PLANAR EPITAXIAL TRANSISTORS FOR AF LOW NOISE PREAMPLIFIER APPLICATIONS. THEY ARE SUPPLIED IN CASE TO-106. TO-92A EQUIVALENTS (PN4248, PN4249, PN4250) ARE ALSO AVAILABLE.

CASE TO-106



CBE

ABSOLUTE MAXIMUM RATINGS

		2N4248	2N4250	2N4249
Collector-Base Voltage	-V _{CB0}	40V	40V	60V
Collector-Emitter Voltage	-V _{CE0}	40V	40V	60V
Emitter-Base Voltage	-V _{EB0}	5V	5V	5V
Collector Current	-I _C		50mA	
Total Power Dissipation (T _C ≤ 65°C)	P _{tot}		300mW	
	(T _A ≤ 25°C)		200mW	
Operating Junction & Storage Temperature	T _j , T _{stg}		-55 to 125°C	

ELECTRICAL CHARACTERISTICS (T_A=25°C unless otherwise noted)

PARAMETER	SYMBOL	2N4248		2N4249		2N4250		UNIT	TEST CONDITIONS
		MIN	MAX	MIN	MAX	MIN	MAX		
Collector-Base Breakdown Voltage	-V _{CB0}	40	60	60	60	40	40	V	-I _C =0.01mA I _B =0
Collector-Emitter Breakdown Voltage	-V _{CE0}	40	60	60	60	40	40	V	-I _C =0.01mA V _{BE} =0
Collector-Emitter Breakdown Voltage	-LV _{CE0}	40	60	60	60	40	40	V	-I _C =5mA (Pulsed) I _B =0
Emitter-Base Breakdown Voltage	-V _{EB0}	5	5	5	5	5	5	V	-I _E =0.01mA I _C =0
Collector Cutoff Current	-I _{CB0}	10 3	10 3	10 3	10 3	10 3	10 3	nA μA	-V _{CB} =40V I _E =0 -V _{CE} =40V I _E =0 T _A =65°C
Emitter Cutoff Current	-I _{EB0}	20	20	20	20	20	20	nA	-V _{EB} =3V I _C =0
Collector-Emitter Saturation Voltage	-V _{CE(sat)}	0.25	0.25	0.25	0.25	0.25	0.25	V	-I _C =10mA -I _B =0.5mA
Base-Emitter Saturation Voltage	-V _{BE(sat)}	0.9	0.9	0.9	0.9	0.9	0.9	V	-I _C =10mA -I _B =0.5mA
D.C. Current Gain	h _{FE}	50 50 50	100 100 100	300 300 300	250 250 250	700 700 700	700 700 700		-I _C =100μA -V _{CE} =5V -I _C =1mA -V _{CE} =5V -I _C =10mA -V _{CE} =5V

2N4248 2N4249 2N4250

PARAMETER	SYMBOL	2N4248	2N4249	2N4250	UNIT	TEST CONDITIONS
		MIN MAX	MIN MAX	MIN MAX		
Small Signal Current Gain	h_{fe}	50 1000	100 550	250 800		$-I_C=1mA$ $-V_{CE}=5V$ $f=1kHz$
Input Impedance	h_{ie}		2.5 17	6 20	$K\Omega$	$-I_C=1mA$ $-V_{CE}=5V$ $f=1kHz$
Output Admittance	h_{oe}		5 40	5 50	μU	$-I_C=1mA$ $-V_{CE}=5V$ $f=1kHz$
Voltage Feedback Ratio	h_{re}		10	10	$\times 10^{-4}$	$-I_C=1mA$ $-V_{CE}=5V$ $f=1kHz$
Current Gain-Bandwidth Product	f_T	40	40	50	MHz	$-I_C=0.5mA$ $-V_{CE}=5V$
Collector-Base Capacitance	C_{ob}	6	6	6	pF	$-V_{CB}=5V$ $I_E=0$ $f=1MHz$
Emitter-Base Capacitance	C_{ib}	16	16	16	pF	$-V_{EB}=0.5V$ $I_C=0$ $f=1MHz$
Noise Figure	NF		3	2	dB	$-I_C=20\mu A$ $-V_{CE}=5V$ $R_C=10K\Omega$ $f=1kHz$
			3	2	dB	$-I_C=20\mu A$ $-V_{CE}=5V$ $R_C=10K\Omega$ $f=10Hz-10kHz$
			3	2	dB	$-I_C=250\mu A$ $-V_{CE}=5V$ $R_C=1K\Omega$ $f=1kHz$

TYPICAL CHARACTERISTICS ($T_A=25^\circ C$ unless otherwise noted)

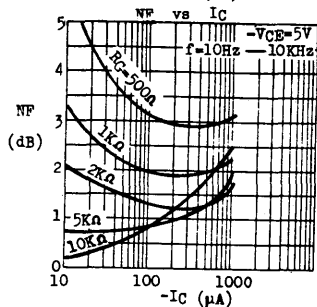
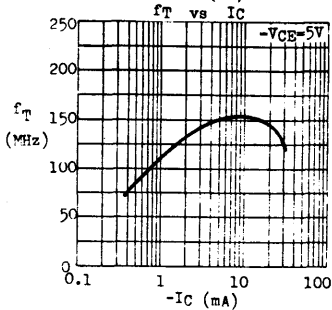
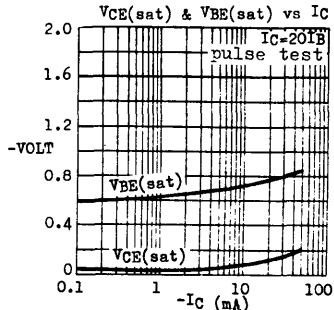
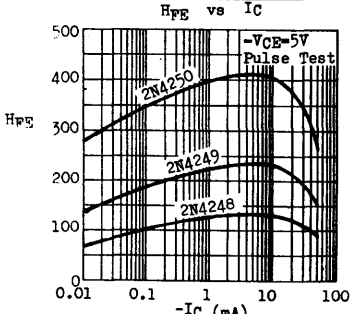

2N4400 2N4401

NPN SILICON GENERAL PURPOSE AMPLIFIERS AND SWITCHES

THE 2N4400, 2N4401 ARE NPN SILICON PLANAR EPITAXIAL TRANSISTORS FOR GENERAL PURPOSE AMPLIFIERS AND MEDIUM SPEED SWITCHING APPLICATIONS. THEY ARE COMPLEMENTARY TO THE PNP TYPE 2N4402 AND 2N4403 RESPECTIVELY.

CASE TO-92A



ABSOLUTE MAXIMUM RATINGS

Collector-Base Voltage	V_{CB0}	60V
Collector-Emitter Voltage	V_{CE0}	40V
Emitter-Base Voltage	V_{EB0}	6V
Collector Current	I_c	0.6A
Total Power Dissipation ($T_A \leq 25^\circ C$)	P_{tot}	500mW **
Operating Junction & Storage Temperature	T_j, T_{stg}	-55 to 150°C

** 310mW in JEDEC registration.

ELECTRICAL CHARACTERISTICS ($T_A=25^\circ C$ unless otherwise noted)

PARAMETER	SYMBOL	2N4400		2N4401		UNIT	TEST CONDITIONS	
		MIN	MAX	MIN	MAX			
Collector-Base Breakdown Voltage	V_{CB0}	60		60		V	$I_C=0.1mA$ $I_E=0$	
Collector-Emitter Breakdown Voltage	V_{CE0}^*	40		40		V	$I_C=1mA$ $I_B=0$	
Emitter-Base Breakdown Voltage	V_{EB0}	6		6		V	$I_C=0.1mA$ $I_C=0$	
Collector Cutoff Current	I_{CEV}		0.1		0.1	μA	$V_{CE}=35V$ $V_{EB}=0.4V$	
Base Cutoff Current	I_{BL}		0.1		0.1	μA	$V_{CE}=35V$ $V_{EB}=0.4V$	
Collector-Emitter Saturation Voltage	$V_{CE(sat)}^*$		0.4		0.4	V	$I_C=150mA$ $I_B=15mA$	
			0.75		0.75	V	$I_C=500mA$ $I_B=50mA$	
Base-Emitter Saturation Voltage	$V_{BE(sat)}^*$	0.75	0.95	0.75	0.95	V	$I_C=150mA$ $I_B=15mA$	
			1.2		1.2	V	$I_C=500mA$ $I_B=50mA$	
D.C. Current Gain	h_{FE}^*			20			$I_C=0.1mA$ $V_{CE}=1V$	
				20	40		$I_C=1mA$ $V_{CE}=1V$	
				40	80		$I_C=10mA$ $V_{CE}=1V$	
			50	150	100	300		$I_C=150mA$ $V_{CE}=1V$
				20	40			$I_C=500mA$ $V_{CE}=2V$
Current Gain-Bandwidth Product	f_T	200		250		MHz	$I_C=20mA$ $V_{CE}=10V$	

2N4400 2N4401

PARAMETER	SYMBOL	2N4400		2N4401		UNIT	TEST CONDITIONS
		MIN	MAX	MIN	MAX		
Collector-Base Capacitance	Cob	6.5		6.5		pF	V _{CB} =5V I _B =0 f=140kHz
Emitter-Base Capacitance	Cib	30		30		pF	V _{EB} =0.5V I _C =0 f=140kHz
Input Impedance	h _{ie}	0.5	7.5	1.0	15	KΩ	I _C =1mA V _{CE} =10V f=1kHz
Voltage Feedback Ratio	h _{re}	0.1	8.0	0.1	8.0	x10 ⁻⁴	I _C =1mA V _{CE} =10V f=1kHz
Small Signal Current Gain	h _{fe}	20	250	40	500		I _C =1mA V _{CE} =10V f=1kHz
Output Admittance	h _{oe}	1	30	1	30	μU	I _C =1mA V _{CE} =10V f=1kHz
Delay Time	t _d	15		15		nS	I _C =150mA I _{B1} =15mA V _{CC} =30V
Rise Time	t _r	20		20		nS	I _C =150mA I _{B1} =15mA V _{CC} =30V
Storage Time	t _s	225		225		nS	I _C =150mA I _{B1} =-I _{B2} =15mA V _{CC} =30V
Fall Time	t _f	30		30		nS	I _C =150mA I _{B1} =-I _{B2} =15mA V _{CC} =30V

* Pulse Test : Pulse Width=0.3mS, Duty Cycle=1%

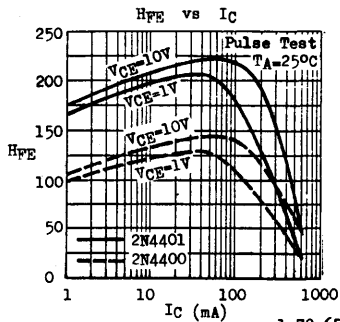
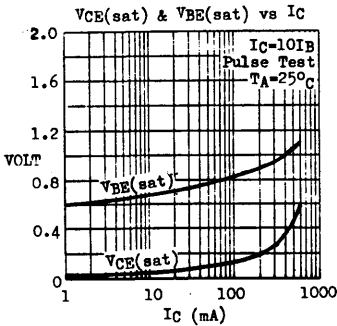
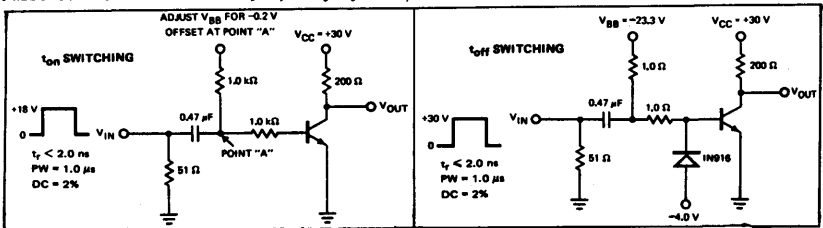

1.78.6500B

2N4402 2N4403

PNP SILICON GENERAL PURPOSE AMPLIFIERS AND SWITCHES

THE 2N4402, 2N4403 ARE PNP SILICON PLANAR EPITAXIAL TRANSISTORS FOR GENERAL PURPOSE AMPLIFIERS AND MEDIUM SPEED SWITCHING APPLICATIONS. THEY ARE COMPLEMENTARY TO THE NPN TYPE 2N4400 AND 2N4401 RESPECTIVELY.

CASE TO-92A



ABSOLUTE MAXIMUM RATINGS

Collector-Base Voltage	-V _{CB0}	40V
Collector-Emitter Voltage	-V _{CE0}	40V
Emitter-Base Voltage	-V _{EB0}	5V
Collector Current	-I _c	0.6A
Total Power Dissipation (T _A ≤ 25°C)	P _{tot}	500mW **
Operating Junction & Storage Temperature	T _j , T _{stg}	-55 to 150°C

** 310mW in JEDEC registration.

ELECTRICAL CHARACTERISTICS (T_A=25°C unless otherwise noted)

PARAMETER	SYMBOL	2N4402		2N4403		UNIT	TEST CONDITIONS
		MIN	MAX	MIN	MAX		
Collector-Base Breakdown Voltage	-V _{CB0}	40		40		V	-I _C =0.1mA I _B =0
Collector-Emitter Breakdown Voltage	-V _{CE0} *	40		40		V	-I _C =1mA I _B =0
Emitter-Base Breakdown Voltage	-V _{EB0}	5		5		V	-I _E =0.1mA I _C =0
Collector Cutoff Current	-I _{CEV}		0.1		0.1	μA	-V _{CE} =35V -V _{EB} =0.4V
Base Cutoff Current	-I _{BL}		0.1		0.1	μA	-V _{CE} =35V -V _{EB} =0.4V
Collector-Emitter Saturation Voltage	-V _{CE(sat)} *		0.4		0.4	V	-I _C =150mA -I _B =15mA
			0.75		0.75	V	-I _C =500mA -I _B =50mA
Base-Emitter Saturation Voltage	-V _{BE(sat)} *	0.75	0.95	0.75	0.95	V	-I _C =150mA -I _B =15mA
			1.3		1.3	V	-I _C =500mA -I _B =50mA
D.C. Current Gain	h _{FE} *		30		30		-I _C =0.1mA -V _{CE} =1V
			30		60		-I _C =1mA -V _{CE} =1V
			50		100		-I _C =10mA -V _{CE} =1V
			50	150	100	300	-I _C =150mA -V _{CE} =2V
			20		20		-I _C =500mA -V _{CE} =2V
Current Gain-Bandwidth Product	f _T	150		200		MHz	-I _C =20mA -V _{CE} =10V

2N4402 2N4403

PARAMETER	SYMBOL	2N4402		2N4403		UNIT	TEST CONDITIONS
		MIN	MAX	MIN	MAX		
Collector-Base Capacitance	Cob	8.5		8.5		pF	-V _{CB} =10V I _E =0 f=140kHz
Emitter-Base Capacitance	Cib	30		30		pF	-V _{EB} =0.5V I _C =0 f=140kHz
Input Impedance	h _{ie}	0.75	7.5	1.5	15	K Ω	-I _C =1mA -V _{CE} =10V f=1kHz
Voltage Feedback Ratio	h _{re}	0.1	8.0	0.1	8.0	x10 ⁴	-I _C =1mA -V _{CE} =10V f=1kHz
Small Signal Current Gain	h _{fe}	30	250	60	500		-I _C =1mA -V _{CE} =10V f=1kHz
Output Admittance	h _{oe}	1	100	1	100	μ S	-I _C =1mA -V _{CE} =10V f=1kHz
Delay Time	t _d	15		15		nS	-I _C =150mA -I _{B1} =15mA -V _{CC} =30V
Rise Time	t _r	20		20		nS	-I _C =150mA -I _{B1} =15mA -V _{CC} =30V
Storage Time	t _s	225		225		nS	-I _C =150mA -I _{B1} =I _{B2} =15mA -V _{CC} =30V
Fall Time	t _f	30		30		nS	-I _C =150mA -I _{B1} =I _{B2} =15mA -V _{CC} =30V

* Pulse Test : Pulse Width=0.3 μ S, Duty Cycle=1%

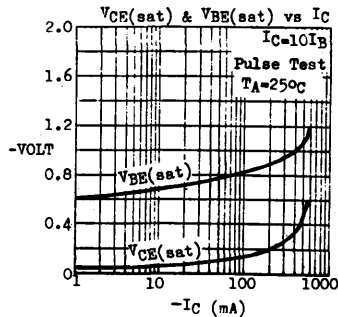
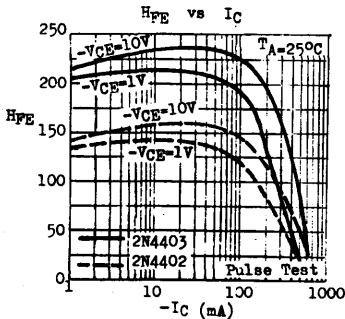
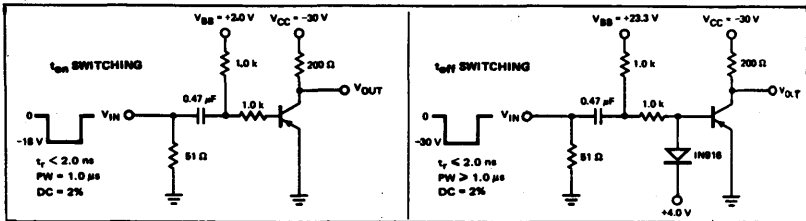

2N4926 2N4927

NPN SILICON HIGH VOLTAGE AMPLIFIERS

THE 2N4926, 2N4927 ARE NPN SILICON PLANAR TRANSISTORS DESIGNED FOR HIGH VOLTAGE MEDIUM POWER AMPLIFIERS AND SWITCHING APPLICATIONS.

CASE TO-30



ABSOLUTE MAXIMUM RATINGS

		2N4926	2N4927
Collector-Base Voltage	V _{CB0}	200V	250V
Collector-Emitter Voltage	V _{CE0}	200V	250V
Emitter-Base Voltage	V _{EB0}	7V	7V
Collector Current	I _C		100mA **
Total Power Dissipation (T _C ≤ 25°C)	P _{tot}		5W
(T _A ≤ 25°C)			1W
Operating Junction & Storage	T _j , T _{stg}		-65 to 200°C

** 50mA in JEDEC registration.

ELECTRICAL CHARACTERISTICS (T_A=25°C unless otherwise noted)

PARAMETER	SYMBOL	2N4926		2N4927		UNIT	TEST CONDITIONS
		MIN	MAX	MIN	MAX		
Collector-Base Breakdown Voltage	BV _{CB0}	200		250		V	I _C =0.1mA I _B =0
Collector-Emitter Breakdown Voltage	LV _{CE0} *	200		250		V	I _C =10mA I _B =0
Emitter-Base Breakdown Voltage	BV _{EB0}	7		7		V	I _E =0.1mA I _C =0
Collector Cutoff Current	I _{CB0}	0.1				μA	V _{CB} =100V I _E =0
		10				μA	V _{CB} =100V I _E =0
				0.1		μA	T _A =100°C V _{CB} =150V I _E =0
				10		μA	T _A =100°C V _{CB} =150V I _E =0
Emitter Cutoff Current	I _{EB0}			0.1		μA	V _{EB} =5V I _C =0
Collector-Emitter Saturation Voltage	V _{CE(sat)} *	1		1		V	I _C =10mA I _B =1mA
		2		2		V	I _C =30mA I _B =3mA
Base-Emitter Saturation Voltage	V _{BE(sat)} *	1.2		1.2		V	I _C =10mA I _B =1mA
		1.5		1.5		V	I _C =50mA I _B =3mA
Base-Emitter Voltage	V _{BE} *	1.5		1.5		V	I _C =30mA V _{CE} =10V
D.C. Current Gain	h _{FE} *	10		10			I _C =3mA V _{CE} =10V
		15		15			I _C =10mA V _{CE} =10V
		20	200	20	200		I _C =30mA V _{CE} =10V
		20		20			I _C =50mA V _{CE} =20V

2N4926 2N4927

PARAMETER	SYMBOL	2N4926		2N4927		UNIT	TEST CONDITIONS
		MIN	MAX	MIN	MAX		
Current Gain-Bandwidth Product	f_T	30	300	30	300	MHz	$I_C=10\text{mA}$ $V_{CE}=20\text{V}$
Collector-Base Capacitance	C_{ob}		6		6	pF	$V_{CB}=20\text{V}$ $I_E=0$ $f=140\text{kHz}$
Input Impedance	h_{ie}	75	2000	75	2000	ohms	$I_C=10\text{mA}$ $V_{CE}=10\text{V}$ $f=1\text{kHz}$
Voltage Feedback Ratio	h_{re}	0.1	2	0.1	2	$\times 10^{-4}$	$I_C=10\text{mA}$ $V_{CE}=10\text{V}$ $f=1\text{kHz}$
Small Signal Current Gain	h_{fe}	25	250	25	250		$I_C=10\text{mA}$ $V_{CE}=10\text{V}$ $f=1\text{kHz}$
Output Admittance	h_{oe}		50		50	μU	$I_C=10\text{mA}$ $V_{CE}=10\text{V}$ $f=1\text{kHz}$
Real Part of Input Impedance	$\text{Re}\{Z_{ie}\}$	4	200	4	200	ohms	$I_C=10\text{mA}$ $V_{CE}=20\text{V}$ $f=5\text{MHz}$

* Pulse Test : Pulse Width=0.3ms, Duty Cycle=1%

TYPICAL CHARACTERISTICS AT $T_A=25^\circ\text{C}$

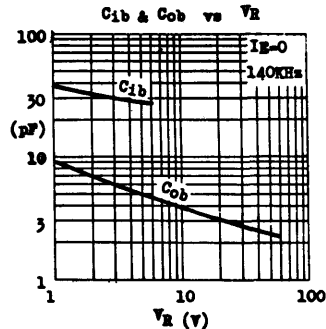
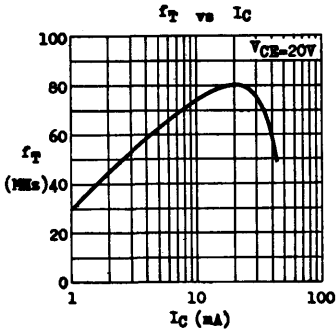
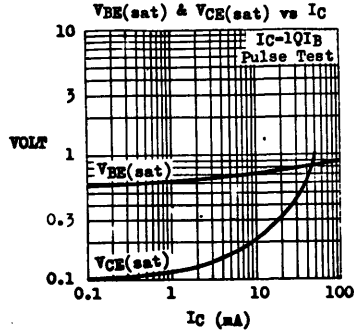
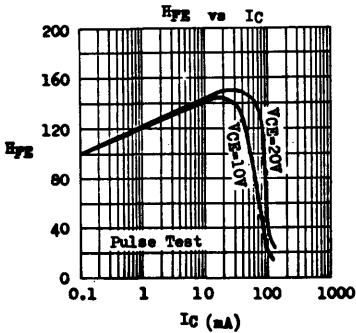

2.78.7300B

2N4964 through 2N4968

PNP NPN SILICON AF SMALL SIGNAL TRANSISTORS

THE 2N4964, 5 (PNP) AND 2N4966, 7, 8 (NPN) ARE SILICON PLANAR EPITAXIAL TRANSISTORS FOR USE IN AF SMALL SIGNAL AMPLIFIERS AND DIRECT COUPLED CIRCUITS.

CASE TO-106



CBE

ABSOLUTE MAXIMUM RATINGS For p-n-p devices, voltage and current values are negative.

	(PNP) 2N4964,5	(NPN) 2N4966,7	(NPN) 2N4968	
Collector-Base Voltage	V _{CB0}	50V	50V	30V
Collector-Emitter Voltage	V _{CE0}	40V	40V	25V
Emitter-Base Voltage	V _{EB0}	5V	6V	6V
Collector Current	I _C	100mA	100mA**	100mA**
Total Power Dissipation (T _A ≤ 25°C)	P _{tot}		200mW	
Operating Junction & Storage Temperature	T _j , T _{stg}		-55 to 125°C	

** 30mA in JEDEC registration.

ELECTRICAL CHARACTERISTICS (T_A = 25°C unless otherwise noted)

PARAMETER	SYMBOL	MIN	TYP	MAX	UNIT	TEST CONDITIONS
Collector-Base Breakdown Voltage	BV _{CB0}	↑				I _C = 0.01mA I _E = 0
Collector-Emitter Breakdown Voltage	LV _{CE0}	Note 1				I _C = 10mA (Pulsed) I _B = 0
Emitter-Base Breakdown Voltage	BV _{EB0}	↓				I _E = 0.01mA I _C = 0
Collector Cutoff Current	I _{CB0}			25	nA	V _{CB} = 20V I _E = 0
	2N4964,5			25	nA	V _{CB} = 25V I _E = 0
	2N4966,7			50	nA	V _{CB} = 25V I _E = 0
	2N4968					
Collector-Emitter Saturation Voltage	V _{CE(sat)}		0.08	0.4	V	I _C = 10mA I _B = 0.5mA
Base-Emitter Voltage	V _{BE}		0.68		V	I _C = 10mA V _{CE} = 5V
D.C. Current Gain	H _{FE}					I _C = 10mA V _{CE} = 5V
	2N4964		30	120		
	2N4965		80	400		
	2N4966,8		40	200		
	2N4967		100	600		
D.C. Current Gain	H _{FE}					I _C = 10mA V _{CE} = 5V
	2N4964		40			
	2N4965		100			
	2N4966,8		50			
	2N4967		120			

Note 1 : equal to the values of absolute maximum ratings.

2N4964 through 2N4968

PARAMETER	SYMBOL	MIN	TYP	MAX	UNIT	TEST CONDITIONS
Current Gain-Bandwidth Product	f _T				MHz	I _C =1mA V _{CE} =5V
		2N4964,5	60			MHz
		2N4966,7,8	40			
Collector-Base Capacitance	C _{ob}				pF	V _{CB} =5V I _E =0
		2N4964,5	4	8		f=1MHz
		2N4966,7,8	3	6		
Noise Figure	NF			6	dB	I _C =10mA V _{CE} =5V R _G =10KΩ f=1KHz

TYPICAL CHARACTERISTICS AT T_A=25°C

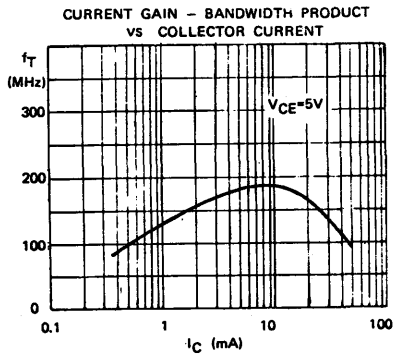
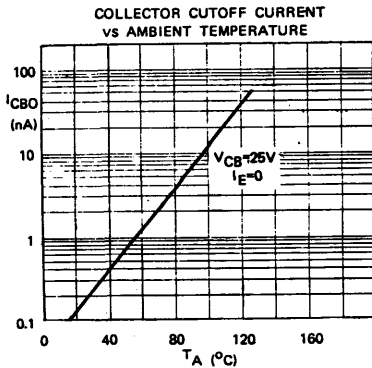
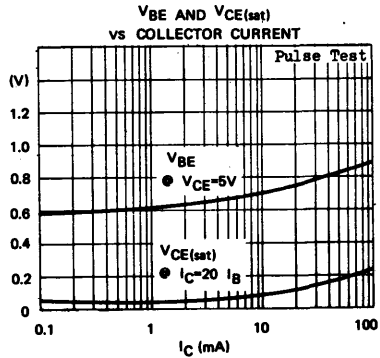
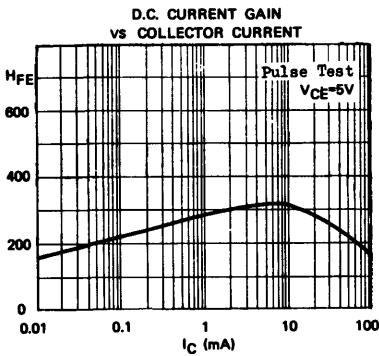

2N4994 2N4995

NPN SILICON RF SMALL TRANSISTORS

THE 2N4994, 2N4995 ARE NPN SILICON PLANAR EPITAXIAL TRANSISTORS FOR RF & IF SMALL SIGNAL APPLICATIONS.

CASE TO-92F



CEB

ABSOLUTE MAXIMUM RATINGS

Collector-Base Voltage	V _{CB0}	60V
Collector-Emitter Voltage	V _{CE0}	45V
Emitter-Base Voltage	V _{EB0}	4V
Collector Current	I _C	30mA
Total Power Dissipation (T _A ≤ 25°C)	P _{tot}	360mW derate 2.88mW/°C above 25°C
Operating Junction & Storage Temperature	T _j , T _{stg}	-55 to 150°C

ELECTRICAL CHARACTERISTICS (T_A=25°C unless otherwise noted)

PARAMETER	SYMBOL	MIN	TYP	MAX	UNIT	TEST CONDITIONS
Collector-Base Breakdown Voltage	BV _{CB0}	60			V	I _C =0.1mA I _E =0
Collector-Emitter Breakdown Voltage	LV _{CE0}	45			V	I _C =10mA (Pulsed) I _B =0
Emitter-Base Breakdown Voltage	BVE _{EB0}	4			V	I _E =0.1mA I _C =0
Collector Cutoff Current	I _{CB0}			100 5	nA μA	V _{CB} =30V I _E =0 V _{CB} =30V I _E =0 T _A =85°C
Collector-Emitter Saturation Voltage	V _{CE(sat)}	0.1	0.5		V	I _C =10mA I _B =1mA
Base-Emitter Voltage	V _{BE}	0.67	0.8		V	I _C =1mA V _{CE} =10V
D.C. Current Gain	H _{FE}	40 100	80 150	160 400		I _C =10mA V _{CE} =10V I _C =10mA V _{CE} =10V
Current Gain-Bandwidth Product	f _T	200	400	800	MHz	I _C =10mA V _{CE} =10V
Collector-Base Capacitance	C _{cb}		1	3.5	pF	V _{CB} =10V I _E =0 f=1MHz
Feedback Time Constant	C _c τ _{bb'}		30	100	pS	I _C =10mA V _{CE} =10V f=79.8MHz

2N4994 2N4995

TYPICAL CHARACTERISTICS AT $T_A=25^\circ\text{C}$

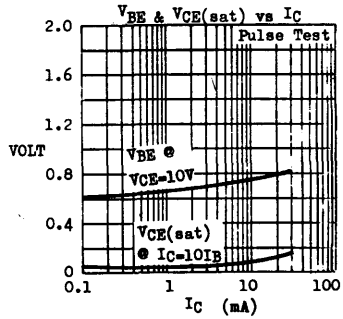
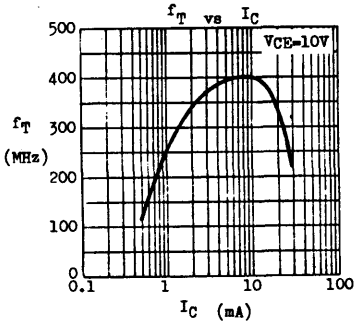
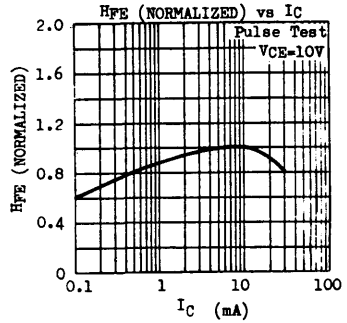
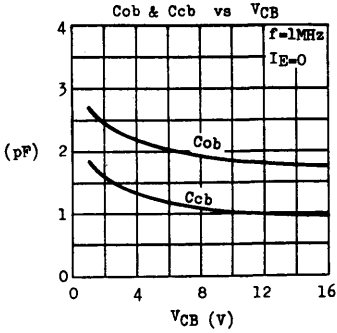

2N5086 2N5087 2N5088 2N5089

PNP NPN SILICON AF LOW NOISE SMALL SIGNAL TRANSISTORS

THE 2N5086, 2N5087 (PNP) AND 2N5088, 2N5089 (NPN) ARE SILICON PLANAR EPITAXIAL TRANSISTORS FOR USE IN AF LOW NOISE PREAMPLIFIER CIRCUITS.

CASE TO-92A



EBC

<u>ABSOLUTE MAXIMUM RATINGS</u> <small>For p-n-p device, voltage and current values are negative.</small>		(PNP) 2N5086	(PNP) 2N5087	(NPN) 2N5088	(NPN) 2N5089
Collector-Base Voltage	V _{CB0}	50V	50V	35V	30V
Collector-Emitter Voltage	V _{CE0}	50V	50V	30V	25V
Emitter-Base Voltage	V _{EB0}	3V	3V	4.5V	4.5V
Collector Current	I _C	50mA			
Total Power Dissipation (T _A ≤ 25°C)	P _{tot}	350mW			
		derate 2.8mW/°C above 25°C			
Operating Junction & Storage Temperature	T _j , T _{stg}	-55 to 150°C			

ELECTRICAL CHARACTERISTICS (T_A = 25°C unless otherwise noted)

PARAMETER	SYMBOL	MIN	TYP	MAX	UNIT	TEST CONDITIONS
Collector-Base Breakdown Voltage	BV _{CB0}				V	I _C = 0.1mA I _E = 0
2N5086,7		50			V	
2N5088		35			V	
2N5089		30			V	
Collector-Emitter Breakdown Voltage	LV _{CE0}				V	I _C = 1mA (Pulsed) I _B = 0
2N5086,7		50			V	
2N5088		30			V	
2N5089		25			V	
Collector Cutoff Current	I _{CBO}				nA	V _{CB} = 10V I _E = 0
2N5086,7				10	nA	
2N5089				50	nA	V _{CB} = 15V I _E = 0
2N5088				50	nA	V _{CB} = 20V I _E = 0
2N5086,7				50	nA	V _{CB} = 35V I _E = 0
Emitter Cutoff Current	I _{EB0}				nA	V _{EB} = 3V I _C = 0
All types				50	nA	
2N5088,9 only				100	nA	V _{EB} = 4.5V I _C = 0
Collector-Emitter Saturation Voltage	V _{CE(sat)}				V	I _C = 10mA I _B = 1mA
2N5086,7			0.08	0.3	V	
2N5088,9			0.08	0.5	V	

2N5086 2N5087 2N5088 2N5089

PARAMETER	SYMBOL	MIN	TYP	MAX	UNIT	TEST CONDITIONS
Base-Emitter Voltage	V _{BE}		0.63	0.85	V	I _C =1mA V _{CE} =5V
		2N5086,7 2N5088,9	0.7	0.8	V	I _C =10mA V _{CE} =5V
Current Gain-Bandwidth Product	f _T		40	80	MHz	I _C =0.5mA V _{CE} =5V
		2N5086,7 2N5088,9	50	100	MHz	I _C =0.5mA V _{CE} =5V
Collector-Base Capacitance All types	C _{ob}		3	4	pF	V _{CB} =5V I _B =0 f=100KHz
Emitter-Base Capacitance 2N5088,9 only	C _{ib}		7	10	pF	V _{EB} =0.5V I _C =0 f=100KHz
Noise Figure	NF	2N5086 only		3	dB	I _C =20μA V _{CE} =5V
		2N5087 only		2	dB	R _C =10KΩ f=10Hz-15KHz
		2N5086 only		3	dB	I _C =100μA V _{CE} =5V
		2N5087 only		2	dB	R _C =3KΩ f=1KHz
		2N5088 only		3	dB	I _C =100μA V _{CE} =5V
		2N5089 only		2	dB	R _C =10KΩ f=10Hz-15KHz

D.C. AND SMALL SIGNAL CURRENT GAIN (H_{FE}, h_{fe}) AT V_{CE}=5V T_A=25°C

TYPE	H _{FE} @ I _C =0.1mA		H _{FE} @ I _C =1mA		H _{FE} @ I _C =10mA		h _{fe} @ I _C =1mA f=1kHz	
	MIN	MAX	MIN	MAX	MIN	MAX	MIN	MAX
2N5086	150	500	150		150		150	600
2N5087	250	800	250		250		250	900
2N5088	300	900	350		300		350	1400
2N5089	400	1200	450		400		450	1800

TYPICAL CHARACTERISTICS AT T_A=25°C

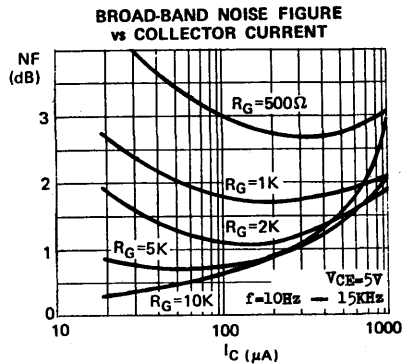
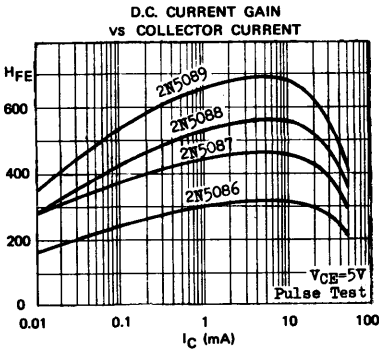

2N5209 2N5210

NPN SILICON AF LOW NOISE SMALL SIGNAL TRANSISTORS

THE 2N5209, 2N5210 ARE NPN SILICON PLANAR EPITAXIAL TRANSISTORS FOR USE IN AF LOW NOISE PREAMPLIFIERS. THEY ARE COMPLEMENTARY TO THE PNP TYPE 2N5086, 2N5087.

CASE TO-92A



EBC

ABSOLUTE MAXIMUM RATINGS

Collector-Base Voltage	V _{CB0}	50V
Collector-Emitter Voltage	V _{CE0}	50V
Emitter-Base Voltage	V _{EB0}	4.5V
Collector Current	I _C	50mA
Total Power Dissipation (T _A ≤ 25°C)	P _{tot}	350mW derate 2.8mW/°C above 25°C
Operating Junction & Storage Temperature	T _j , T _{stg}	-55 to 150°C

ELECTRICAL CHARACTERISTICS (T_A=25°C unless otherwise noted)

PARAMETER	SYMBOL	2N 5209		2N 5210		UNIT	TEST CONDITIONS
		MIN	MAX	MIN	MAX		
Collector-Base Breakdown Voltage	V _{CB0}	50		50		V	I _C =0.1mA I _B =0
Collector-Emitter Breakdown Voltage	V _{CE0}	50		50		V	I _C =1mA (Pulsed) I _B =0
Collector Cutoff Current	I _{CB0}		50		50	nA	V _{CB} =35V I _B =0
Emitter Cutoff Current	I _{EB0}		50		50	nA	V _{EB} =3V I _C =0
Collector-Emitter Saturation Voltage	V _{CE(sat)}	0.7		0.7		V	I _C =10mA I _B =1mA
Base-Emitter Voltage	V _{BE}	0.85		0.85		V	I _C =1mA V _{CE} =5V
D.C. Current Gain	h _{FE}	100	300	200	600		I _C =0.1mA V _{CE} =5V
		150		250			I _C =1mA V _{CE} =5V
		150		250			I _C =10mA V _{CE} =5V
Current Gain-Bandwidth Product	f _T	30		30		MHz	I _C =0.5mA V _{CE} =5V
Collector-Base Capacitance	C _{ob}		4		4	pF	V _{CB} =5V I _B =0 f=1MHz
Small Signal Current Gain	h _{fe}	150	600	250	900		I _C =1mA V _{CE} =5V f=1KHz
Noise Figure	N _F		3		2	dB	I _C =20μA V _{CE} =5V R _C =22KΩ f=10Hz-15KHz
	N _F		4		3	dB	I _C =20μA V _{CE} =5V R _C =10KΩ f=1KHz

2N5209 2N5210

TYPICAL CHARACTERISTICS ($T_A=25^\circ\text{C}$ UNLESS OTHERWISE SPECIFIED)

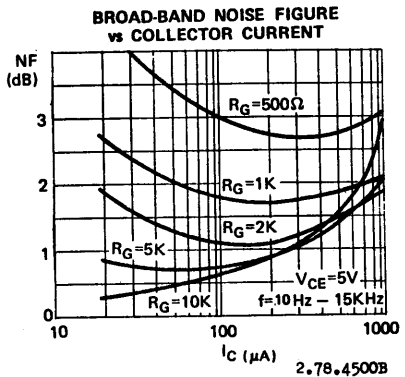
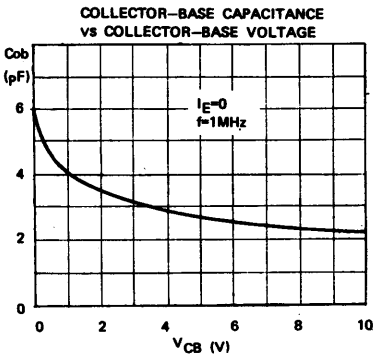
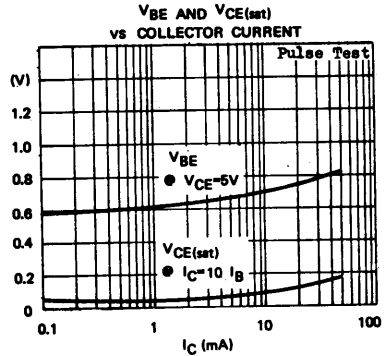
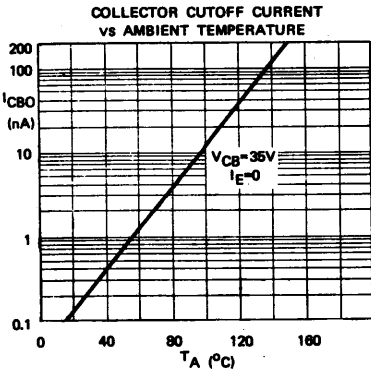
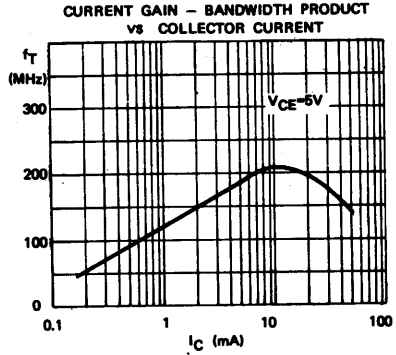
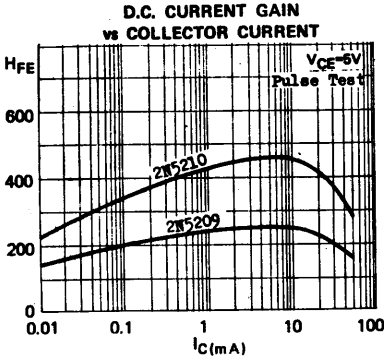

2.78.4500B

2N5294 2N5296 2N5298

NPN SILICON SINGLE DIFFUSED MESA POWER TRANSISTORS

THE 2N 5294, 2N 5296 AND 2N 5298 ARE NPN SILICON SINGLE DIFFUSED MESA POWER TRANSISTORS DESIGNED FOR LOW SPEED SWITCHING AND AUDIO AMPLIFIER APPLICATIONS. THEY FEATURE LARGE SAFE OPERATING AREA.

CASE TO-220B



ABSOLUTE MAXIMUM RATINGS

Collector-Base Voltage
 Collector-Emitter Voltage
 Emitter-Base Voltage
 Collector Current
 Base Current
 Total Power Dissipation @ $T_C < 25^\circ\text{C}$
 @ $T_A < 25^\circ\text{C}$

Junction Temperature
 Storage Temperature Range

THERMAL RESISTANCE

Junction to Case
 Junction to Ambient

	2N 5294	2N 5296	2N 5298
V_{CB0}	80V	60V	80V
V_{CE0}	70V	40V	60V
V_{EB0}	7V	5V	5V
I_C		4A	
I_B		2A	
P_{tot}		36W	
		1.8W	
T_j		150°C	
T_{stg}		-55 to +150°C	
θ_{jc}		3.5°C/W	max.
θ_{ja}		70°C/W	max.

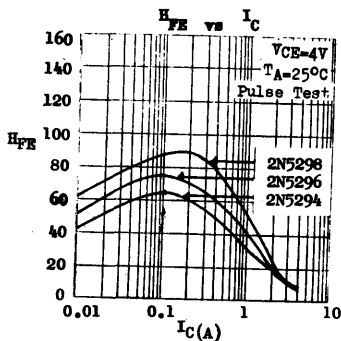
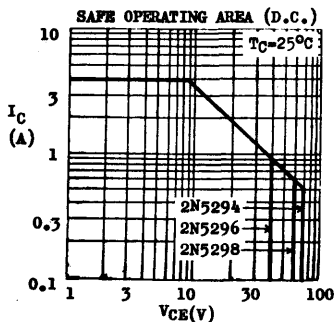

2N5294 2N5296 2N5298

ELECTRICAL CHARACTERISTICS ($T_A=25^\circ\text{C}$ unless otherwise noted)

PARAMETER	SYMBOL	MIN	TYP	MAX	UNIT	TEST CONDITIONS
Collector-Emitter Breakdown Voltage	LV _{CEO} *	70			V	I _C =0.1A I _B =0
2N 5294		40			V	
2N 5296		60			V	
Collector-Emitter Breakdown Voltage	LV _{CER} *	75			V	I _C =0.1A R _{BE} =100Ω
2N 5294		50			V	
2N 5296		70			V	
Collector-Emitter Breakdown Voltage	LV _{CEV} *	80			V	I _C =0.1A V _{EB} =-1.5V
2N 5294/8		60			V	
Collector Cutoff Current	2N 5294/8	IC _{ER}		0.5	mA	V _{CE} =50V R _{BE} =100Ω
Collector Cutoff Current	2N 5294/8	IC _{ER}		2	mA	V _{CE} =50V R _{BE} =100Ω T _C =150°C
Collector Cutoff Current	2N 5294/8	IC _{EV}		0.5	mA	V _{CE} =65V V _{EB} =-1.5V
2N 5296				2	mA	V _{CE} =35V V _{EB} =-1.5V
Collector Cutoff Current	2N 5294/8	IC _{EV}		3	mA	V _{CE} =65V V _{EB} =-1.5V
2N 5296				5	mA	V _{CE} =35V V _{EB} =-1.5V T _C =150°C
Emitter Cutoff Current	2N 5294	I _{EBO}		1	mA	V _{EB} =-7V I _C =0
2N 5296/8			1	mA	V _{EB} =-5V I _C =0	
Base-Emitter Voltage	2N 5294	V _{BE} *	0.70	1.1	V	I _C =0.5A V _{CE} =4V
2N 5296	0.80		1.3	V	I _C = 1 A V _{CE} =4V	
2N 5298	0.90		1.5	V	I _C =1.5A V _{CE} =4V	
Collector-Emitter Saturation Voltage	V _{CE(sat)} *		0.15	1	V	I _C =0.5A I _B =0.05A
2N 5294			0.20	1	V	I _C = 1 A I _B =0.1 A
2N 5296			0.30	1	V	I _C =1.5A I _B =0.15A
D.C. Current Gain	2N 5294	h _{FE} *	30	120		I _C =0.5A V _{CE} =4V
2N 5296	30		120		I _C = 1 A V _{CE} =4V	
2N 5298	20		80		I _C =1.5A V _{CE} =4V	
Current Gain-Bandwidth Product	f _T	0.8			MHz	I _C =0.2A V _{CE} =4V

* Pulse Test : Pulse Width=0.3ms, Duty Cycle=1%

2N5368 through 2N5375

COMPLEMENTARY SILICON GENERAL PURPOSE AMPLIFIERS AND SWITCHES

COMPLEMENTARY SILICON GENERAL PURPOSE AMPLIFIERS AND SWITCHES

THE ABOVE TYPES ARE SILICON PLANAR EPITAXIAL TRANSISTORS FOR GENERAL PURPOSE AMPLIFIERS AND MEDIUM SPEED SWITCHING APPLICATIONS.

CASE TO-92F



<u>ABSOLUTE MAXIMUM RATINGS</u>		2N5368 (NPN)	2N5372 (PNP)	2N5369 (NPN)	2N5373 (PNP)	2N5371 (NPN)	2N5375 (PNP)
Collector-Base Voltage	V _{CB0}	60V	60V	40V			
Collector-Emitter Voltage	V _{CE0}	30V	30V	30V			
Emitter-Base Voltage	V _{EB0}	5V	5V	5V			
Collector Current	I _C	500mA	500mA	500mA			
Total Power Dissipation (T _A ≤ 25°C)	P _{tot}		500mW **				
			derate 4mW/°C above 25°C				
Operating Junction & Storage Temperature T _J , T _{stg}			-55 to 150°C				
** 360mW in JEDEC registration.							

ELECTRICAL CHARACTERISTICS (T_A=25°C unless otherwise noted)

PARAMETER	SYMBOL	MIN	TYP	MAX	UNIT	TEST CONDITIONS
Collector-Base Breakdown Voltage	V _{CB0}	↑			V	I _C =0.01mA I _B =0
Collector-Emitter Breakdown Voltage	V _{CE0} *	Note 1			V	I _C =10mA I _B =0
Emitter-Base Breakdown Voltage	V _{EB0}	↓			V	I _E =0.01mA I _C =0
Collector Cutoff Current	I _{CB0}				nA	V _{CB} =40V I _E =0
				50	nA	V _{CE} =40V I _E =0
				50	nA	V _{CE} =30V I _E =0
Emitter Cutoff Current	I _{EB0}			50	nA	V _{EB} =3V I _C =0
Collector-Emitter Saturation Voltage	V _{CE(sat)} *		0.18	0.3	V	I _C =150mA I _B =15mA
Base-Emitter Saturation Voltage	V _{BE(sat)} *		0.84	1.3	V	I _C =150mA I _B =15mA
Base-Emitter Voltage	V _{BE} *		0.8	1.2	V	I _C =150mA V _{CE} =10V
Current Gain-Bandwidth Product	f _T		250	370	MHz	I _C =20mA V _{CE} =10V
			150	270	MHz	I _C =20mA V _{CE} =10V
Collector-Base Capacitance	C _{cb}			8	pF	V _{CB} =10V I _E =0
				10	pF	f=1MHz

Note 1 : Equal to the values of absolute maximum ratings.

* Pulse Test ; Pulse Width=0.3mS, Duty Cycle=1%

For p-n-p devices, voltage and current values are negative.

2N5368 through 2N5375

PARAMETER	SYMBOL	MIN	MAX	UNIT	TEST CONDITIONS
Turn-On Time (Note 2) 2N5368 thru' 2N5371 2N5372 thru' 2N5375	t_{on}	40		nS	$I_C=150mA$ $I_{B1}=15mA$ $V_{CC}=30V$
		50		nS	$I_C=150mA$ $I_{B1}=15mA$ $V_{CC}=30V$
Turn-Off Time (Note 2) 2N5368,69 2N5370,71 2N5372,73 2N5374,75	t_{off}	350		nS	$I_C=150mA$ $I_{B1}=-I_{B2}=15mA$ $V_{CC}=30V$
		400		nS	$V_{CC}=30V$
		150		nS	$I_C=150mA$ $I_{B1}=-I_{B2}=15mA$ $V_{CC}=6V$
		175		nS	$V_{CC}=6V$

Note 2 : Test circuits referred to 2N2222/2N2907 data sheets.

D.C. CURRENT GAIN (HFE) AT $T_A=25^\circ C$ $V_{CE}=10V$

	HFE @ $I_C=1mA$		HFE @ $I_C=10mA$		HFE @ $I_C=150mA$	
	MIN	MAX	MIN	MAX	MIN	MAX
2N5368	20		40		60	200
2N5369	50		75		100	300
2N5370	75		150		200	600
2N5371	20		40		60	600
2N5372	20		30		40	120
2N5373	50		75		100	300
2N5374	100		150		200	400
2N5375	20		30		40	400

TYPICAL CHARACTERISTICS ($T_A=25^\circ C$ Pulse Test)

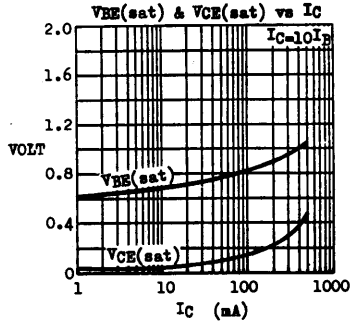
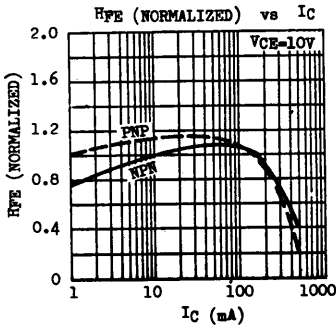

2N5400 2N5401 2N5550 2N5551

COMPLEMENTARY SILICON GENERAL PURPOSE HIGH VOLTAGE TRANSISTORS

THE 2N5400, 2N5401 (PNP) AND 2N5550, 2N5551 (NPN)
ARE COMPLEMENTARY SILICON PLANAR EPITAXIAL
TRANSISTORS INTENDED FOR GENERAL PURPOSE HIGH
VOLTAGE AMPLIFIER AND SWITCHING APPLICATIONS.

CASE TO-92A



EBC

ABSOLUTE MAXIMUM RATINGS	For p-p signals, voltage and current values are negative	(PNP)	(PNP)	(NPN)	(NPN)
		2N5400	2N5401	2N5550	2N5551
Collector-Base Voltage	V _{CB0}	130V	160V	160V	180V
Collector-Emitter Voltage	V _{CE0}	120V	150V	140V	160V
Emitter-Base Voltage	V _{EB0}	5V	5V	6V	6V
Collector Current	I _C	600mA			
Total Power Dissipation (T _C ≤ 25°C)	P _{tot}	1W			
		derate 8mW/°C above 25°C			
		350mW			
		derate 2.8mW/°C above 25°C			
Operating Junction & Storage Temperature	T _j , T _{stg}	-55 to 150°C			

ELECTRICAL CHARACTERISTICS (T_A = 25°C unless otherwise noted)

PARAMETER	SYMBOL	MIN	MAX	UNIT	TEST CONDITIONS
Collector-Base Breakdown Voltage	BV _{CB0}	↓ Note 1 ↓			I _C = 0.1mA I _E = 0
Collector-Emitter Breakdown Voltage	LV _{CE0}				I _C = 1mA I _B = 0
Emitter-Base Breakdown Voltage	BV _{EB0}				I _E = 0.01mA I _C = 0
Collector Cutoff Current	I _{CB0}		100	nA	V _{CB} = 100V I _E = 0
			50	nA	V _{CB} = 120V I _E = 0
Collector Cutoff Current	I _{CB0}		100	μA	V _{CB} = 100V I _E = 0
			50	μA	T _A = 100°C V _{CB} = 120V I _E = 0 T _A = 100°C
Emitter Cutoff Current	I _{EB0}		50	nA	V _{EB} = 3V I _C = 0
			50	nA	V _{EB} = 4V I _C = 0
Collector-Emitter Saturation Voltage	V _{CE(sat)}		0.2	V	I _C = 10mA I _B = 1mA
			0.15	V	I _C = 10mA I _B = 1mA

Note 1 : Equal to the values of absolute maximum ratings.

2N5400 2N5401 2N5550 2N5551

PARAMETER	SYMBOL	MIN	TYP	MAX	UNIT	TEST CONDITIONS
Collector-Emitter Saturation Voltage 2N5400, 5401 2N5550 2N5551	$V_{CE(sat)}$			0.5 0.25 0.2	V V V	$I_C=50mA$ $I_B=2mA$ $I_C=50mA$ $I_B=2mA$ $I_C=50mA$ $I_B=2mA$
Base-Emitter Saturation Voltage All types 2N5400, 5401 2N5550 2N5551	$V_{BE(sat)}$			1 1 1.2 1	V V V V	$I_C=10mA$ $I_B=1mA$ $I_C=50mA$ $I_B=2mA$ $I_C=50mA$ $I_B=2mA$ $I_C=50mA$ $I_B=2mA$
Current Gain-Bandwidth Product 2N5400 2N5401, 5550, 5551	f_T	100 100	160 160	400 300	MHz MHz	$I_B=10mA$ $V_{CE}=10V$ $I_C=10mA$ $V_{CE}=10V$
Collector-Base Capacitance	C_{ob}			4	6	pF $V_{CB}=10V$ $I_B=0$ $f=1MHz$
Emitter-Base Capacitance 2N5550 only 2N5551 only	C_{ib}			30 20	pF pF	$V_{BE}=0.5V$ $I_C=0$ $f=1MHz$
Noise Figure 2N5400, 5401, 5551 only 2N5550 only	NF			8 10	dB dB	$I_C=250\mu A$ $V_{CE}=5V$ $R_G=1k\Omega$ $f=10Hz-15KHz$

D.C. AND SMALL SIGNAL CURRENT GAIN AT $T_A=25^\circ C$

TYPE	HFE						h_{fe} @ $I_C=1mA$ $V_{CE}=10V$ $f=1kHz$	
	@ $I_C=1mA$ $V_{CE}=5V$		@ $I_C=10mA$ $V_{CE}=5V$		@ $I_C=50mA$ $V_{CE}=5V$		MIN	MAX
	MIN	MAX	MIN	MAX	MIN	MAX		
2N5400	30		40	180	40		30	200
2N5401	50		60	240	50		40	200
2N5550	60		60	250	20		50	200
2N5551	80		80	250	30		50	200

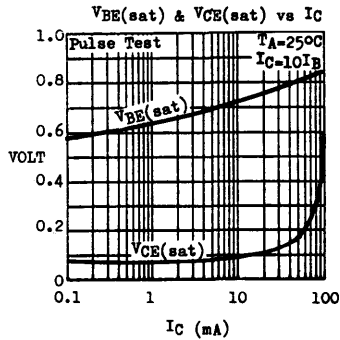
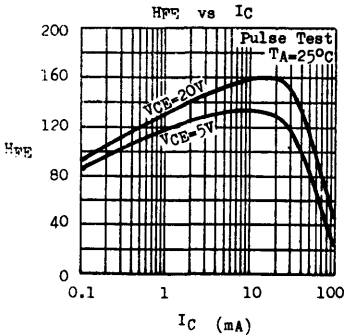

2N5447 through 2N5450

COMPLEMENTARY SILICON GENERAL PURPOSE AF TRANSISTORS

THE 2N5447, 2N5448, 2N5449, 2N5450 ARE SILICON PLANAR EPITAXIAL TRANSISTORS FOR GENERAL PURPOSE MEDIUM POWER AMPLIFIER APPLICATIONS. THE 2N5447, 2N5448 ARE PNP AND ARE COMPLEMENTARY TO THE NPN 2N5449, 2N5450 RESPECTIVELY.

CASE TO-92F



ABSOLUTE MAXIMUM RATINGS	For p-n-p devices, voltage and current values are negative.			
	2N5447 (PNP)	2N5448 (PNP)	2N5449 (NPN)	2N5450 (NPN)
Collector-Base Voltage	V _{CB0}	40V	50V	50V
Collector-Emitter Voltage	V _{CE0}	25V	30V	30V
Emitter-Base Voltage	V _{EB0}	5V	5V	5V
Collector Current	I _C	0.2A	0.2A	0.8A
Collector Peak Current (t ≤ 10ms)	I _{CM}	0.6A	0.6A	
Total Power Dissipation (T _C ≤ 25°C)	P _{tot}		1.2W	
			500mW **	
Operating Junction & Storage Temperature	T _j , T _{stg}			-55 to 150°C

** 360mW in JEDEC registration.

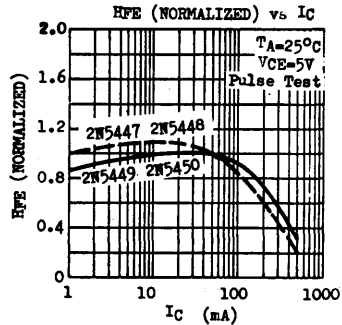
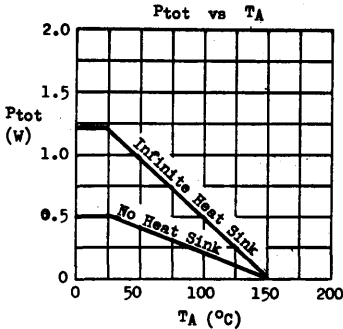

2N5447 through 2N5450

ELECTRICAL CHARACTERISTICS ($T_A=25^\circ\text{C}$ unless otherwise noted)

PARAMETER	SYMBOL	MIN	TYP	MAX	UNIT	TEST CONDITIONS
Collector-Base Breakdown Voltage	BV_{CBO}					$I_C=0.1\text{mA}$ $I_B=0$
2N5447		40			V	
2N5448, 2N5449, 2N5450		50			V	
Collector-Emitter Breakdown Voltage	BV_{CEO}^*					$I_C=10\text{mA}$ $I_B=0$
2N5447		25			V	
2N5448, 2N5449, 2N5450		30			V	
Emitter-Base Breakdown Voltage	BV_{EBO}	5			V	$I_E=0.1\text{mA}$ $I_C=0$
Collector Cutoff Current	I_{CBO}			100	nA	$V_{CB}=20\text{V}$ $I_E=0$
Emitter Cutoff Current	I_{EBO}			100	nA	$V_{EB}=3\text{V}$ $I_C=0$
Collector-Emitter Saturation Voltage	$V_{CE(sat)}^*$					
2N5447, 2N5448			0.25		V	$I_C=50\text{mA}$ $I_B=5\text{mA}$
2N5449			0.6		V	$I_C=100\text{mA}$ $I_B=5\text{mA}$
2N5450			0.8		V	$I_C=100\text{mA}$ $I_B=5\text{mA}$
Base-Emitter Voltage	V_{BE}^*					
2N5447, 2N5448		0.6	1.0		V	$I_C=50\text{mA}$ $V_{CE}=5\text{V}$
2N5449, 2N5450		0.5	1.0		V	$I_C=100\text{mA}$ $V_{CE}=2\text{V}$
D.C. Current Gain	β_{FE}^*					
2N5447		60	300			$I_C=50\text{mA}$ $V_{CE}=5\text{V}$
2N5448		30	150			$I_C=50\text{mA}$ $V_{CE}=5\text{V}$
2N5449		100	300			$I_C=50\text{mA}$ $V_{CE}=2\text{V}$
2N5450		50	150			$I_C=50\text{mA}$ $V_{CE}=2\text{V}$
Current Gain-Bandwidth Product	f_T					
2N5447, 2N5448		100			MHz	$I_C=50\text{mA}$ $V_{CE}=5\text{V}$
2N5449, 2N5450		100			MHz	$I_C=50\text{mA}$ $V_{CE}=2\text{V}$
Collector-Base Capacitance	C_{ob}			12	pF	$V_{CB}=10\text{V}$ $I_B=0$ $f=1\text{MHz}$

* Pulse Test : Pulse Width=0.3ms, Duty Cycle=1%

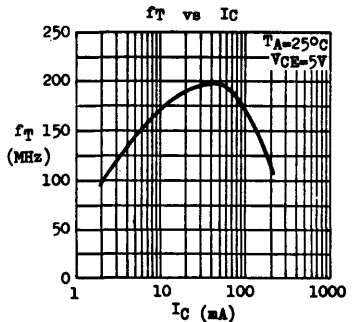
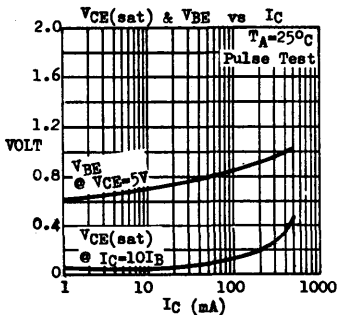

1.78.0650B.6500B

2N5490 2N5492 2N5494 2N5496

NPN SILICON SINGLE DIFFUSED MESA POWER TRANSISTORS

THE 2N 5490, 2N 5492, 2N 5494 AND 2N 5496 ARE NPN SILICON SINGLE DIFFUSED MESA POWER TRANSISTORS DESIGNED FOR LOW SPEED SWITCHING AND AUDIO AMPLIFIER APPLICATIONS. THEY FEATURE LARGE SAFE OPERATING AREA.

CASE TO-220B



ABSOLUTE MAXIMUM RATINGS

Collector-Base Voltage
 Collector-Emitter Voltage
 Emitter-Base Voltage
 Collector Current
 Base Current
 Total Power Dissipation @ $T_C=25^\circ\text{C}$
 @ $T_A=25^\circ\text{C}$
 Junction Temperature
 Storage Temperature Range

	2N5490/4	2N5492	2N5496
VCBO	60V	75V	90V
VCEO	40V	55V	70V
VEBO		5V	
IC		7A	
IB		3A	
Ptot		50W	
		1.8W	
Tj		150°C	
Tstg		-55 to +150°C	

THERMAL RESISTANCE

Junction to Case
 Junction to Ambient

θ_{jc}	2.5°C/W	max.
θ_{ja}	70°C/W	max.

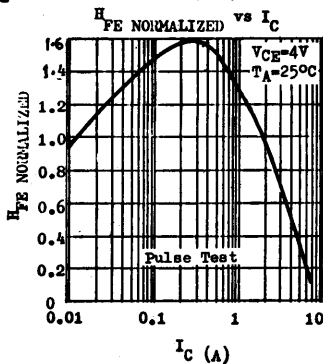
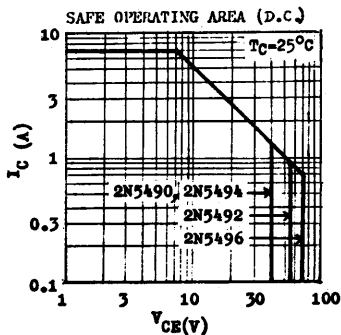

2N5490 2N5492 2N5494 2N5496

ELECTRICAL CHARACTERISTICS ($T_A=25^\circ\text{C}$ unless otherwise noted)

PARAMETER	SYMBOL	MIN	TYP	MAX	UNIT	TEST CONDITIONS
Collector-Emitter Breakdown Voltage 2N5490/4 2N5492 2N5496	LVCEO *	40			V	$I_C=0.1\text{A}$ $I_B=0$
		55			V	
		70			V	
Collector-Emitter Breakdown Voltage 2N5490/4 2N5492 2N5496	LVCEB *	50			V	$I_C=0.1\text{A}$ $R_{BE}=100\Omega$
		65			V	
		80			V	
Collector-Emitter Breakdown Voltage 2N5490/4 2N5492 2N5496	LVCEV *	60			V	$I_C=0.1\text{A}$ $V_{EB}=1.5\text{V}$
		75			V	
		90			V	
Collector Cutoff Current 2N5490 2N5492 2N5494 2N5496	ICER			2	mA	$V_{CE}=4.0\text{V}$ $R_{BE}=100\Omega$
				0.5	mA	$V_{CE}=5.5\text{V}$ $R_{BE}=100\Omega$
				0.5	mA	$V_{CE}=4.0\text{V}$ $R_{BE}=100\Omega$
				0.5	mA	$V_{CE}=7.0\text{V}$ $R_{BE}=100\Omega$
Collector Cutoff Current @ $T_C=150^\circ\text{C}$ 2N5490 2N5492 2N5494 2N5496	ICER			5	mA	$V_{CE}=4.0\text{V}$ $R_{BE}=100\Omega$
				3.5	mA	$V_{CE}=5.5\text{V}$ $R_{BE}=100\Omega$
				3.5	mA	$V_{CE}=4.0\text{V}$ $R_{BE}=100\Omega$
				3.5	mA	$V_{CE}=7.0\text{V}$ $R_{BE}=100\Omega$
Collector Cutoff Current 2N5492 2N5494 2N5496	ICEV			1	mA	$V_{CE}=7.0\text{V}$ $V_{EB}=1.5\text{V}$
				1	mA	$V_{CE}=5.5\text{V}$ $V_{EB}=1.5\text{V}$
				1	mA	$V_{CE}=8.5\text{V}$ $V_{EB}=1.5\text{V}$
Collector Cutoff Current @ $T_C=150^\circ\text{C}$ 2N5492 2N5494 2N5496	ICEV			5	mA	$V_{CE}=7.0\text{V}$ $V_{EB}=1.5\text{V}$
				5	mA	$V_{CE}=5.5\text{V}$ $V_{EB}=1.5\text{V}$
				5	mA	$V_{CE}=8.5\text{V}$ $V_{EB}=1.5\text{V}$
Emitter Cutoff Current	IEBO			1	mA	$V_{EB}=5\text{V}$ $I_C=0$
Base-Emitter Voltage 2N5490 2N5492 2N5494 2N5496	VBE *	0.83	1.1		V	$I_C=2\text{A}$ $V_{CE}=4\text{V}$
		0.92	1.3		V	$I_C=2.5\text{A}$ $V_{CE}=4\text{V}$
		1.0	1.5		V	$I_C=3\text{A}$ $V_{CE}=4\text{V}$
		1.05	1.7		V	$I_C=3.5\text{A}$ $V_{CE}=4\text{V}$
Collector-Emitter Saturation Voltage 2N5490 2N5492 2N5494 2N5496	VCE(sat) *	0.25	1		V	$I_C=2\text{A}$ $I_B=0.2\text{A}$
		0.3	1		V	$I_C=2.5\text{A}$ $I_B=0.25\text{A}$
		0.35	1		V	$I_C=3\text{A}$ $I_B=0.3\text{A}$
		0.4	1		V	$I_C=3.5\text{A}$ $I_B=0.35\text{A}$
D.C. Current Gain 2N5490 2N5492 2N5494 2N5496	HFE *	20		100		$I_C=2\text{A}$ $V_{CE}=4\text{V}$
		20		100		$I_C=2.5\text{A}$ $V_{CE}=4\text{V}$
		20		100		$I_C=3\text{A}$ $V_{CE}=4\text{V}$
		20		100		$I_C=3.5\text{A}$ $V_{CE}=4\text{V}$
Current Gain-Bandwidth Product	f_T	0.8			MHz	$I_C=0.5\text{A}$ $V_{CE}=4\text{V}$

* Pulse Test : Pulse Width=0.3ms, Duty Cycle=1%

2N5810 through 2N5819

COMPLEMENTARY SILICON AF MEDIUM POWER TRANSISTORS

THE 2N5810 THROUGH 2N5819 ARE SILICON PLANAR EPITAXIAL TRANSISTORS FOR USE IN AF DRIVERS AND OUTPUTS, AS WELL AS FOR UNIVERSAL APPLICATIONS. THEY ARE SUPPLIED IN TO-92F PLASTIC CASE WITH OPTIONAL X-67 HEAT SINK. THE 2N5810, 2, 4, 6, 8 ARE NPN AND ARE COMPLEMENTARY TO THE PNP 2N5811, 3, 5, 7, 9.

CASE TO-92F WITH X-67
LEAD PREPARED HEAT SINK

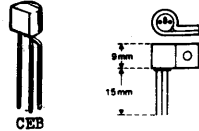

ABSOLUTE MAXIMUM RATINGS For p-n-p devices, voltage and current values are negative.

		2N5810, 2(NPN) 2N5811, 3(PNP)	2N5814, 6, 8(NPN) 2N5815, 7, 9(PNP)
Collector-Base Voltage	V _{CB0}	35V	50V
Collector-Emitter Voltage (V _{BE} =0)	V _{CE0}	35V	50V
Collector-Emitter Voltage (I _B =0)	V _{CE0}	25V	40V
Emitter-Base Voltage	V _{EB0}		5V
Collector Current	I _C	0.75A	
Collector Peak Current (t ≤ 10μs)	I _{CM}	1.5A	
Total Power Dissipation @ T _C ≤ 25°C	P _{tot}	1.4W	
With X-67 Heat Sink @ T _A ≤ 25°C			800mW
No Heat Sink @ T _A ≤ 25°C			625mW **
Operating Junction & Storage Temperature	T _j , T _{stg}	-55 to 150°C	

** 500mW in JEDEC registration.

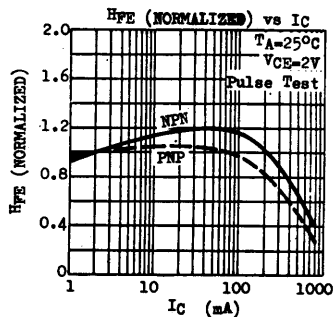
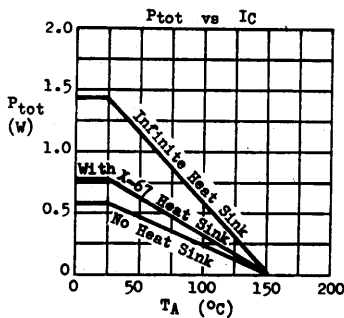

2N5810 through 2N5819

ELECTRICAL CHARACTERISTICS (TA=25°C unless otherwise noted)

PARAMETER	SYMBOL	2N5810 thru' 2N5819		UNIT	TEST CONDITIONS
		MIN	MAX		
Collector-Base Breakdown Voltage 2N5810, 1, 2, 3 2N5814, 5, 6, 7, 8, 9	BVCES	35 50		V V	IC=0.01mA VBE=0
Collector-Emitter Breakdown Voltage 2N5810, 1, 2, 3 2N5814, 5, 6, 7, 8, 9	LVCEO *	25 40		V V	IC=10mA IB=0
Collector Cutoff Current	ICBO		100	nA	VCE=25V IB=0
			15	µA	VCE=25V IB=0 TA=100°C
Emitter Cutoff Current	IEBO		10	µA	VBE=5V IC=0
Collector-Emitter Saturation Voltage	VCE(sat)*		0.75	V	IC=500mA IB=50mA
Base-Emitter Saturation Voltage	VBE(sat)*		1.2	V	IC=500mA IB=50mA
Base-Emitter Voltage	VBE *	0.6	1.1	V	IC=500mA VCE=2V
D.C. Current Gain 2N5810, 1 2N5812, 3 2N5814, 5 2N5816, 7 2N5818, 9	HFE *		200		IC=2mA VCE=2V
			500		
			120		
			200		
			300		
D.C. Current Gain 2N5810, 1 2N5812, 3 2N5814, 5 2N5816, 7 2N5818, 9	HFE *				IC=500mA VCE=2V
			45		
			60		
			20		
			25		
Current Gain-Bandwidth Product 2N5810, 1, 4, 5 2N5816, 7 2N5812, 3, 8, 9	fT			MHz	IC=50mA VCE=2V
			120	MHz	
			135	MHz	
Collector-Base Capacitance	Cob		15	pF	VCE=10V IB=0 f=1MHz
Emitter-Base Capacitance	Cib		55	pF	VBE=0.5V IC=0 f=1MHz

* Pulse Test ; Pulse Width=0.3µS, Duty Cycle=1%

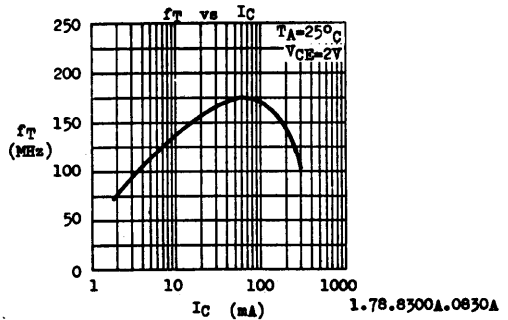
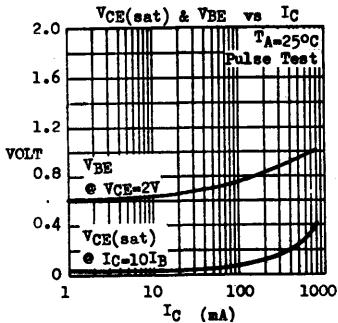

1.78.8300A.0830A

2N5820 through 2N5823

COMPLEMENTARY SILICON AF MEDIUM POWER TRANSISTORS

THE 2N5820 THROUGH 2N5823 ARE SILICON PLANAR EPITAXIAL TRANSISTORS FOR USE IN AF DRIVERS AND OUTPUTS, AS WELL AS FOR UNIVERSAL APPLICATIONS. THEY ARE SUPPLIED IN TO-92F PLASTIC CASE WITH OPTIONAL X-67 HEAT SINK. THE 2N5820, 2N5822 ARE NPN AND ARE COMPLEMENTARY TO THE PNP 2N5821, 2N5823.

CASE TO-92F X-67 Heat Sink

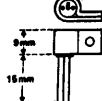

ABSOLUTE MAXIMUM RATINGS For p-n-p devices, voltage and current values are negative.

Collector-Base Voltage
 Collector-Emitter Voltage ($V_{BE}=0$)
 Collector-Emitter Voltage ($I_B=0$)
 Emitter-Base Voltage
 Collector Current
 Total Power Dissipation ($T_C \leq 25^\circ\text{C}$)
 With X-67 Heat Sink ($T_A \leq 25^\circ\text{C}$)
 No Heat Sink ($T_A \leq 25^\circ\text{C}$)
 Operating Junction & Storage Temperature

	2N5820, 2 (NPN)
	2N5821, 3 (PNP)
V_{CB0}	70V
V_{CES}	70V
V_{CEO}	60V
V_{EB0}	5V
I_C	1A **
P_{tot}	1.4W **
	800mW**
	625mW**
T_j, T_{stg}	-55 to 150°C

** This exceeds JEDEC registered value.

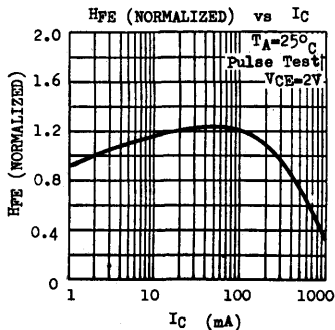
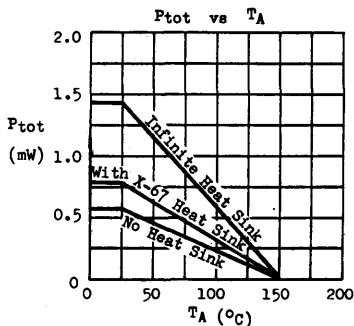

2N5820 through 2N5823

ELECTRICAL CHARACTERISTICS ($T_A=25^\circ\text{C}$ unless otherwise noted)

PARAMETER	SYMBOL	MIN	TYP	MAX	UNIT	TEST CONDITIONS
Collector-Emitter Breakdown Voltage	BV_{CES}	70			V	$I_C=0.01\text{mA}$ $V_{BE}=0$
Collector-Emitter Breakdown Voltage	LV_{CEO}^*	60			V	$I_C=10\text{mA}$ $I_B=0$
Collector Cutoff Current	I_{CBO}		100		nA	$V_{CB}=25\text{V}$ $I_E=0$
			15		μA	$V_{CB}=25\text{V}$ $I_E=0$ $T_A=100^\circ\text{C}$
Emitter Cutoff Current	I_{EBO}		10		μA	$V_{EB}=5\text{V}$ $I_C=0$
Collector-Emitter Saturation Voltage	$V_{CE(sat)}^*$	0.25	0.75		V	$I_C=500\text{mA}$ $I_B=50\text{mA}$
Base-Emitter Saturation Voltage	$V_{BE(sat)}^*$	0.9	1.2		V	$I_C=500\text{mA}$ $I_B=50\text{mA}$
Base-Emitter Voltage	V_{BE}^*	0.6	0.85	1.1	V	$I_C=500\text{mA}$ $V_{CE}=2\text{V}$
D.C. Current Gain	H_{FE}^*		60	120		$I_C=2\text{mA}$ $V_{CE}=2\text{V}$
			100	200		$I_C=2\text{mA}$ $V_{CE}=2\text{V}$
			20			$I_C=500\text{mA}$ $V_{CE}=2\text{V}$
			25			$I_C=500\text{mA}$ $V_{CE}=2\text{V}$
Collector-Base Capacitance	C_{cb}		15		pF	$V_{CB}=10\text{V}$ $I_E=0$ $f=1\text{MHz}$
Current Gain-Bandwidth Product	f_T		140		MHz	$I_C=50\text{mA}$ $V_{CE}=2\text{V}$

* Pulse Test : Pulse Width=0.3ms, Duty Cycle=1%

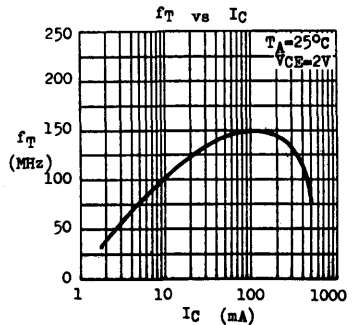
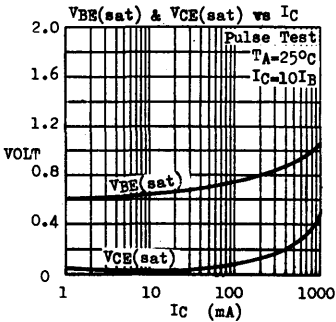

2N5824 through 2N5828

NPN SILICON AF SMALL SIGNAL TRANSISTORS

THE 2N5824 THROUGH 2N5828 ARE NPN SILICON PLANAR EPITAXIAL TRANSISTORS FOR USE IN AF SMALL SIGNAL AMPLIFIERS AND DIRECT COUPLED CIRCUITS.

CASE TO-92F



ABSOLUTE MAXIMUM RATINGS

Collector-Base Voltage	V_{CB0}	50V
Collector-Emitter Voltage	V_{CE0}	40V
Emitter-Base Voltage	V_{EB0}	5V
Collector Current	I_C	100mA
Total Power Dissipation ($T_A \leq 25^\circ\text{C}$)	P_{tot}	360mW
		derate 2.88mW/°C above 25°C
Operating Junction & Storage Temperature	T_j, T_{stg}	-55 to 150°C

ELECTRICAL CHARACTERISTICS ($T_A=25^\circ\text{C}$ unless otherwise noted)

PARAMETER	SYMBOL	MIN	TYP	MAX	UNIT	TEST CONDITIONS
Collector-Base Breakdown Voltage	BV_{CB0}	50			V	$I_C=0.01\text{mA}$ $I_E=0$
Collector-Emitter Breakdown Voltage	BV_{CE0}	40			V	$I_C=10\text{mA}$ (Pulsed) $I_E=0$
Collector Cutoff Current	I_{CB0}			50 10	nA μA	$V_{CB}=40\text{V}$ $I_E=0$ $V_{CE}=40\text{V}$ $I_E=0$ $T_A=100^\circ\text{C}$
Emitter Cutoff Current	I_{EB0}			50	nA	$V_{EB}=5\text{V}$ $I_C=0$
Collector-Emitter Saturation Voltage	$V_{CE(sat)}$	0.07	0.125		V	$I_C=10\text{mA}$ $I_B=1\text{mA}$
Base-Emitter Saturation Voltage	$V_{BE(sat)}$	0.7	0.78		V	$I_C=10\text{mA}$ $I_B=1\text{mA}$
Base-Emitter Voltage	V_{BE}	0.5	0.65	0.9	V	$I_C=2\text{mA}$ $V_{CE}=10\text{V}$
Current Gain-Bandwidth Product	f_T			250 350	MHz	$I_C=2\text{mA}$ $V_{CE}=10\text{V}$ $I_C=2\text{mA}$ $V_{CE}=10\text{V}$
		90			MHz	$I_C=2\text{mA}$ $V_{CE}=10\text{V}$ $f=1\text{MHz}$
Collector-Base Capacitance	C_{cb}		1.9	4	pF	$V_{CB}=10\text{V}$ $I_E=0$
Feedback Time Constant	$C_{c'bb'}$			65 80 100	pS	$I_C=2\text{mA}$ $V_{CE}=10\text{V}$ $f=31.8\text{MHz}$
					pS	
					pS	

2N5824 through 2N5828

D.C. AND SMALL SIGNAL CURRENT GAIN (H_{FE} , h_{fe}) AT $T_A=25^\circ\text{C}$

TYPE	$H_{FE} @ I_C=2\text{mA } V_{CE}=5\text{V}$		$h_{fe} @ I_C=2\text{mA } V_{CE}=5\text{V } f=1\text{KHz}$	
	MIN	MAX	MIN	MAX
2N5824	60	120	60	180
2N5825	100	200	100	300
2N5826	150	300	150	450
2N5827	250	500	250	750
2N5828	400	800	400	1200

TYPICAL CHARACTERISTICS AT $T_A=25^\circ\text{C}$

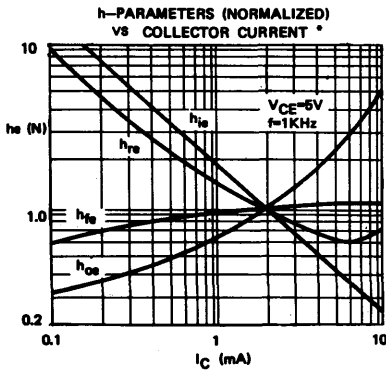
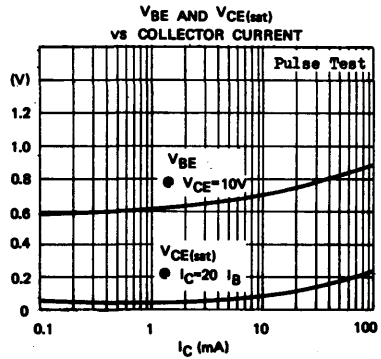
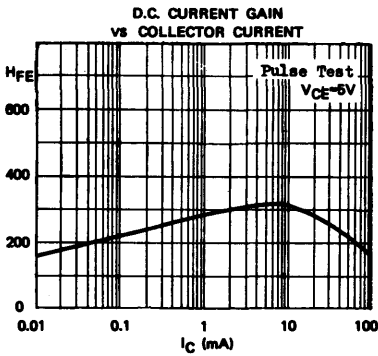

*Typical values at $I_C=2\text{mA } V_{CE}=5\text{V}$	
$H_{FE}(\text{D.C.})$	300
$h_{ie}(1\text{KHz})$	4.6Kohms
$h_{fe}(1\text{KHz})$	330
$h_{re}(1\text{KHz})$	2×10^{-4}
$h_{oe}(1\text{KHz})$	30 μmhos

2N6027 2N6028

PROGRAMMABLE UNIJUNCTION TRANSISTORS

The Micro Electronics Programmable Unijunction Transistor (PUT) is a three-terminal planar passivated PNP device in TO-92 package. The terminals are designated as anode, gate and cathode.

The 2N 6027 and 2N 6028 offer outstanding circuit design flexibility. External resistors can be selected to meet designers' needs in programming the unijunction characteristics such as η , R_{BB} , I_p and I_v .

The 2N 6028 is designed for long interval timers and other applications requiring low peak point current. The 2N 6027 is designed for general use where the low peak point current of the 2N 6028 is not essential.

For further information, refer to Application Notes Nos. 143, 144 and 158.

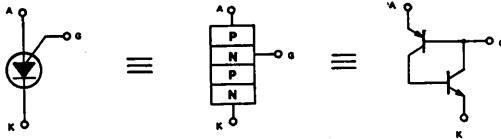

FEATURES

- PROGRAMMABLE η , R_{BB} , I_p , I_v
- LOW LEAKAGE CURRENT
- LOW PEAK POINT CURRENT
- LOW FORWARD VOLTAGE
- HIGH PULSE OUTPUT VOLTAGE
- LOW COST

APPLICATIONS

- OSCILLATORS AND TIMERS
- TRIGGER DEVICES
- LATCHING SWITCHES
- PULSE SHAPING CIRCUITS
- SENSING CIRCUITS

PACKAGE TO-92

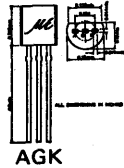

ABSOLUTE MAXIMUM RATINGS

Voltage

Gate-Cathode Forward Voltage	+40 V
Gate-Cathode Reverse Voltage	-5 V
Gate-Anode Reverse Voltage	+40 V
Anode-Cathode Voltage	± 40 V

Current

DC Forward Anode Current*	150 mA
Peak Forward Anode Current, Repetitive (100 μ sec pulse width, 1% duty cycle)	1 A
(20 μ sec pulse width, 1% duty cycle)	2 A

Current

Peak Forward Anode Current, Non-repetitive (10 μ sec pulse)	5 A
DC Gate Current	± 20 mA

Capacitive Discharge Energy† 250 μ J

Power

Total Average Power* 300 mW

Temperature

Operating Ambient*
Temperature Range -50°C to +100°C

*Derate currents and powers 1%/°C above 25°C

†E=½ CV² capacitor discharge energy with no current limiting

2N6027 2N6028

ELECTRICAL CHARACTERISTICS AT $T_A = 25^\circ\text{C}$ (unless otherwise specified)

CHARACTERISTICS	SYMBOL	FIG. NO.	2N6027		2N6028		UNITS	TEST CONDITIONS
			Min.	Max.	Min.	Max.		
Peak Point Current	I_P	1		2	.15	μA	$V_S = 10\text{ Volts}$ $R_G = 1\text{ M}\Omega$	
Offset Voltage	V_T	1	.2	1.6	.2	.6	Volts	$V_S = 10\text{ Volts}$ $R_G = 10\text{ K}\Omega$
			.2	.6	.2	.6	Volts	$V_S = 10\text{ Volts}$ $R_G = 10\text{ K}\Omega$
Valley Current	I_V	1		50		25	μA	$V_S = 10\text{ Volts}$ $R_G = 1\text{ M}\Omega$
				70		25	μA	$V_S = 10\text{ Volts}$ $R_G = 10\text{ K}\Omega$
Gate-Anode Leakage Current	I_{GAO}	2		10	10	nA	$V_S = 40\text{ Volts}$, $T_A = 25^\circ\text{C}$	
				100	100	nA	$T_A = 75^\circ\text{C}$	
Gate - Cathode Leakage Current	I_{GKS}	3		100	100	nA	$V_S = 40\text{ Volts}$, $V_A = 0$	
Forward Voltage	V_F	1		1.5	1.5	Volts	$I_F = 50\text{ mA}$	
Pulse Output Voltage	V_O	4		6	6	Volts		
Pulse Voltage Rate of Rise	t_r	4		80	80	nsec.		

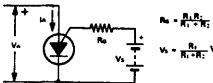
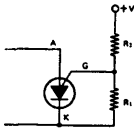

$$R_g = \frac{R_1 R_2}{R_1 + R_2}$$

$$V_T = V_G - V_S$$

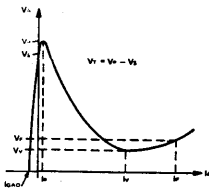

Figure 1

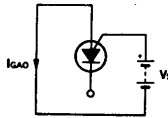

Figure 2

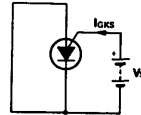

Figure 3

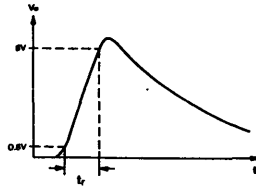
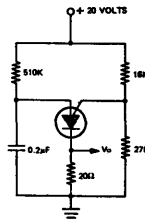
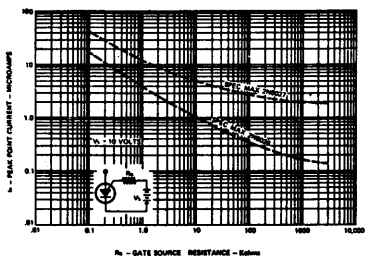
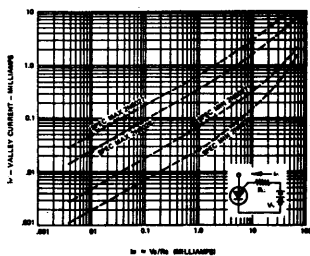

Figure 4

TYPICAL CHARACTERISTICS AT $T_A = 25^\circ\text{C}$ (unless otherwise specified)



I_p VS GATE SOURCE RESISTANCE



I_v VS "ON STATE" GATE CURRENT

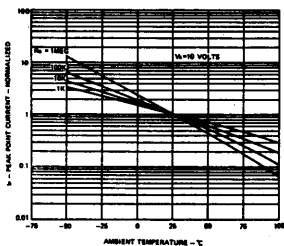

I_p VS TEMPERATURE AND R_g

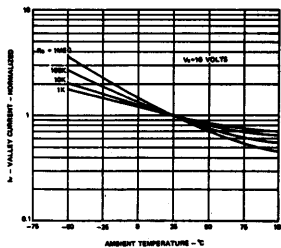

I_v VS TEMPERATURE AND R_g

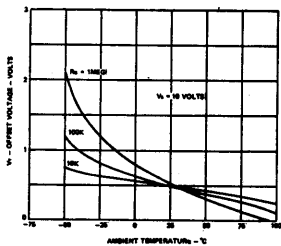

V_o VS TEMPERATURE AND R_g

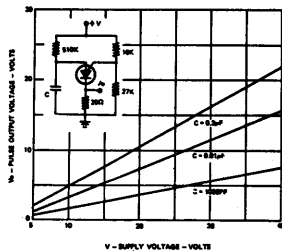

PULSE OUTPUT VOLTAGE

APPLICATIONS

Precision Relaxation Oscillator

The use of the diode 1N4154 and 1 meg resistor at the gate gives low peak point current, therefore reducing the shunting effect of the PUT on Cr during the charging period. The diode also temperature compensates V_{AG} which drifts at about $-2.5mV$ per $^{\circ}C$.

The circuit oscillates at 100Hz which is kept within 1% from $-30^{\circ}C$ to $75^{\circ}C$.

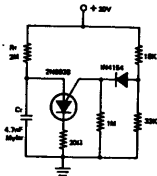

Ten-minute Time Delay Relay

The PUT uses high gate source resistance (1M-ohms) and draws negligible current from the RC network during the delay time. When the SCS is triggered by the PUT, the relay is energized. C is short-circuited by a pair of relay contacts. This condition ensures that accurate timing is repeatable because C is always charged from zero volt after the circuit is reset. Time delay is approximately 10 minutes at $R = 4.7$ M-ohms.

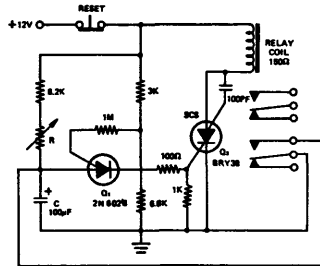

Monostable Multivibrator

The PUT is normally ON. A positive pulse at the input turns Q_1 on, C is discharged rapidly through the saturation resistance of the collector-emitter junction. The PUT becomes OFF. At the removal of the input pulse, Q_1 is cut off. C is charged through R towards +20V. When the peak point voltage is reached, Q_2 fires and returns to the latching state again due to the large holding current through R.

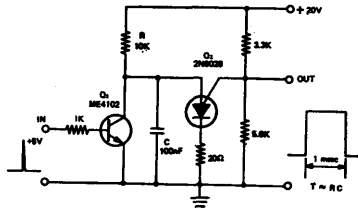

Warble Alarm Circuit

This alarm can be easily heard in noisy background. Q_2 and Q_3 forms a tone generator in which the fundamental frequency is modulated by the sawtooth output of Q_1 .

Tone frequency $\approx (500-800)Hz$

Sawtooth frequency $\approx 2.5Hz$

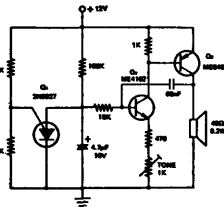

SCR Phase Control

The conduction angle of the SCR is controlled by the PUT oscillator which is synchronized from the a.c. line. This ensures that the SCR is triggered at the same point on the a.c. cycle each time.

The conduction angle of the SCR can be varied from 30° to 160° by using the 100 k-ohm variable resistor.

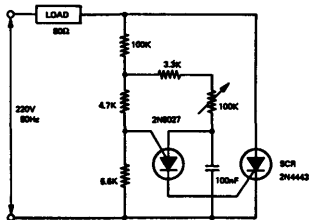

2N6111 2N6109 2N6107

PNP SILICON EPITAXIAL BASE POWER TRANSISTORS

THE 2N 6111, 2N 6109 AND 2N 6107 ARE PNP SILICON EPITAXIAL BASE POWER TRANSISTORS DESIGNED FOR SWITCHING, DRIVER AND OUTPUT STAGES IN AUDIO AMPLIFIERS. THE 2N 6111, 2N 6109 AND 2N 6107 ARE COMPLEMENTARY TO 2N 6288, 2N 6290 AND 2N 6292 RESPECTIVELY.

CASE TO-220B



ABSOLUTE MAXIMUM RATINGS

Collector-Base Voltage
 Collector-Emitter Voltage
 Emitter-Base Voltage
 Collector Current
 Base Current
 Total Power Dissipation @ $T_C=25^\circ\text{C}$
 @ $T_A=25^\circ\text{C}$
 Junction Temperature
 Storage Temperature Range

	2N 6111	2N 6109	2N 6107
-V _{CB0}	40V	60V	80V
-V _{CE0}	30V	50V	70V
-V _{EB0}		5V	
-I _C		7A	
-I _B		3A	
P _{tot}		40W	
		1.8W	
T _j		150°C	
T _{stg}		-55 to +150°C	

THERMAL RESISTANCE

Junction to Case

θ_{jc} 3.12°C/W max.

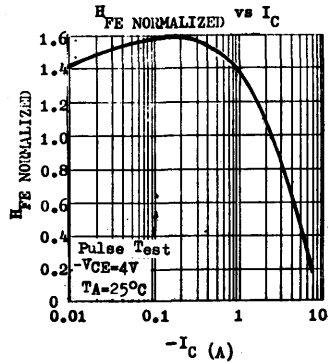
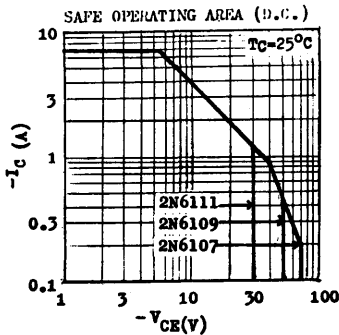

2N6111 2N6109 2N6107

ELECTRICAL CHARACTERISTICS ($T_A=25^\circ\text{C}$ unless otherwise noted)

PARAMETER	SYMBOL	MIN	TYP	MAX	UNIT	TEST CONDITIONS
Collector-Emitter Breakdown Voltage 2N 6111 2N 6109 2N 6107	$-V_{CE0}^*$	30 50 70			V V V	$-I_C=0.1A$ $I_B=0$
Collector-Emitter Breakdown Voltage 2N 6111 2N 6109 2N 6107	$-V_{CEB}^*$	40 60 80			V V V	$-I_C=0.1A$ $R_{BE}=100\Omega$
Collector-Emitter Cutoff Current 2N 6111 2N 6109 2N 6107	$-I_{CE0}$		1 1 1		mA mA mA	$-V_{CE}=20V$ $I_B=0$ $-V_{CE}=40V$ $I_B=0$ $-V_{CE}=60V$ $I_B=0$
Collector-Emitter Cutoff Current 2N 6111 2N 6109 2N 6107	$-I_{CEB}$		0.1 0.1 0.1		mA mA mA	$-V_{CE}=35V$ $R_{BE}=100\Omega$ $-V_{CE}=55V$ $R_{BE}=100\Omega$ $-V_{CE}=75V$ $R_{BE}=100\Omega$
Collector-Emitter Cutoff Current 2N 6111 2N 6109 2N 6107			2 2 2		mA mA mA	$-V_{CE}=30V$ $R_{BE}=100\Omega$ $T_C=150^\circ\text{C}$ $-V_{CE}=50V$ $R_{BE}=100\Omega$ $T_C=150^\circ\text{C}$ $-V_{CE}=70V$ $R_{BE}=100\Omega$ $T_C=150^\circ\text{C}$
Collector-Emitter Cutoff Current 2N 6111 2N 6109 2N 6107	$-I_{CEV}$		0.1 0.1 0.1		mA mA mA	$-V_{CE}=37.5V$ $-V_{EB}=1.5V$ $-V_{CE}=56V$ $-V_{EB}=1.5V$ $-V_{CE}=75V$ $-V_{EB}=1.5V$
Collector-Emitter Cutoff Current 2N 6111 2N 6109 2N 6107			2 2 2		mA mA mA	$-V_{CE}=30V$ $-V_{EB}=1.5V$ $T_C=150^\circ\text{C}$ $-V_{CE}=50V$ $-V_{EB}=1.5V$ $T_C=150^\circ\text{C}$ $-V_{CE}=70V$ $-V_{EB}=1.5V$ $T_C=150^\circ\text{C}$
Emitter-Base Cutoff Current	$-I_{EB0}$		1		mA	$-V_{EB}=5V$ $I_C=0$
Collector-Emitter Saturation Voltage 2N 6111 2N 6109 2N 6107 All types	$-V_{CE(sat)}^*$	0.35 0.3 0.3	1 1 1		V V V	$-I_C=3A$ $-I_B=0.3A$ $-I_C=2.5A$ $-I_B=0.25A$ $-I_C=2A$ $-I_B=0.2A$ $-I_C=7A$ $-I_B=3A$
Base-Emitter Voltage 2N 6111 2N 6109 2N 6107 All types	$-V_{BE}^*$	1.05 0.97 0.93	1.5 1.5 1.5		V V V	$-I_C=3A$ $-V_{CE}=4V$ $-I_C=2.5A$ $-V_{CE}=4V$ $-I_C=2A$ $-V_{CE}=4V$ $-I_C=7A$ $-V_{CE}=4V$
D.C. Current Gain 2N 6111 2N 6109 2N 6107 All types	h_{FE}^*	30 30 30	150 150 150			$-I_C=3A$ $-V_{CE}=4V$ $-I_C=2.5A$ $-V_{CE}=4V$ $-I_C=2A$ $-V_{CE}=4V$ $-I_C=7A$ $-V_{CE}=4V$
Current Gain-Bandwidth Product	f_T	10			MHz	$-I_C=0.5A$ $-V_{CE}=4V$
Collector-Base Capacitance	C_{ob}		250		pF	$-V_{CB}=10V$ $I_E=0$ $f=1\text{MHz}$
Small Signal Current Gain	h_{fe}	20				$-I_C=0.5A$ $-V_{CE}=4V$ $f=50\text{KHz}$

* Pulse Test : Pulse Width=0.3ms, Duty Cycle=1%

2N6121 2N6122 2N6123

NPN SILICON EPITAXIAL BASE POWER TRANSISTORS

THE 2N 6121, 2N 6122 AND 2N 6123 ARE NPN SILICON EPITAXIAL BASE POWER TRANSISTORS DESIGNED FOR SWITCHING, DRIVER AND OUTPUT STAGES IN AUDIO AMPLIFIERS. THE 2N 6121, 2N 6122, 2N 6123 ARE COMPLEMENTARY TO 2N 6124, 2N 6125, 2N 6126 RESPECTIVELY.

CASE TO-220B



ABSOLUTE MAXIMUM RATINGS

Collector-Base Voltage
 Collector-Emitter Voltage
 Emitter-Base Voltage
 Collector Current
 Base Current
 Total Power Dissipation ($T_C \leq 25^\circ\text{C}$)
 Junction Temperature
 Storage Temperature Range

	2N 6121	2N 6122	2N 6123
V_{CBO}	45V	60V	80V
V_{CEO}	45V	60V	80V
V_{EBO}		5V	
I_C		4A	
I_B		1A	
P_{tot}		40W	
T_j		150°C	
T_{stg}		-55 to +150°C	

THERMAL RESISTANCE

Junction to Case

θ_{jc}

3.12°C/W max.

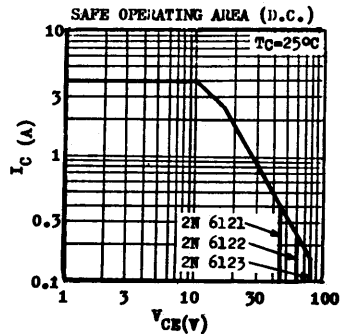
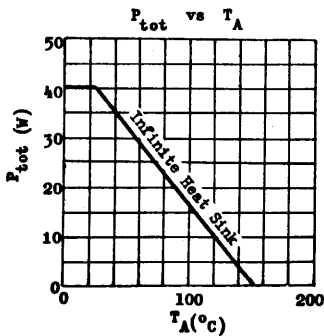

2N6121 2N6122 2N6123

ELECTRICAL CHARACTERISTICS ($T_A=25^\circ\text{C}$ unless otherwise noted)

PARAMETER	SYMBOL	MIN	TYP	MAX	UNIT	TEST CONDITIONS
Collector-Emitter Breakdown Voltage 2N 6121 2N 6122 2N 6123	V_{CE0}^*	45 60 80			V V V	$I_C=0.1\text{A}$ $I_B=0$
Collector-Base Cutoff Current	I_{CBO}		0.1		mA	$V_{CB}=V_{CBO}$ $I_E=0$
Collector-Emitter Cutoff Current	I_{CEO}		1		mA	$V_{CE}=V_{CBO}$ $I_B=0$
Collector-Emitter Cutoff Current	I_{CEV}		0.1 2		mA mA	$V_{CE}=V_{CBO}$ $V_{EB}=1.5\text{V}$ $V_{CE}=V_{CBO}$ $V_{EB}=1.5\text{V}$ $T_C=125^\circ\text{C}$
Emitter-Base Cutoff Current	I_{EBO}		1		mA	$V_{EB}=5\text{V}$ $I_C=0$
Collector-Emitter Saturation Voltage	$V_{CE(sat)}^*$	0.28 1.4	0.6		V V	$I_C=1.5\text{A}$ $I_B=0.15\text{A}$ $I_C=4\text{A}$ $I_B=1\text{A}$
Base-Emitter Voltage	V_{BE}^*	0.87	1.2		V	$I_C=1.5\text{A}$ $V_{CE}=2\text{V}$
D.C. Current Gain 2N 6121, 6122	H_{FE}^*	25	100			$I_C=1.5\text{A}$ $V_{CE}=2\text{V}$
2N 6123	H_{FE}^*	20	80			$I_C=1.5\text{A}$ $V_{CE}=2\text{V}$
2N 6121, 6122	H_{FE}^*	10				$I_C=4\text{A}$ $V_{CE}=2\text{V}$
2N 6123	H_{FE}^*	7				$I_C=4\text{A}$ $V_{CE}=2\text{V}$
Current Gain-Bandwidth Product	f_T	2.5			MHz	$I_C=1\text{A}$ $V_{CE}=4\text{V}$
Small Signal Current Gain	h_{fe}	25				$I_C=0.1\text{A}$ $V_{CE}=2\text{V}$ $f=1\text{kHz}$

* Pulse Test : Pulse Width=0.3ms, Duty Cycle=1%

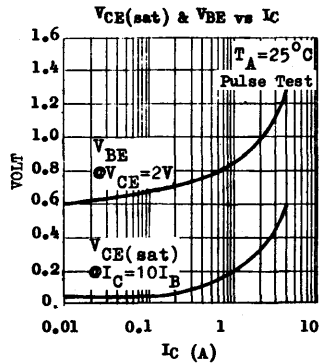
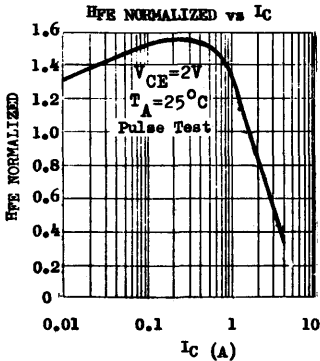

2N6124 2N6125 2N6126

PNP SILICON EPITAXIAL BASE POWER TRANSISTORS

THE 2N 6124, 2N 6125 AND 2N 6126 ARE PNP SILICON EPITAXIAL BASE POWER TRANSISTORS DESIGNED FOR SWITCHING, DRIVER AND OUTPUT STAGES IN AUDIO AMPLIFIERS. THE 2N 6124, 2N 6125, 2N 6126 ARE COMPLEMENTARY TO 2N 6121, 2N 6122, 2N 6123 RESPECTIVELY.

CASE TO-220B



ABSOLUTE MAXIMUM RATINGS

Collector-Base Voltage	- V _{CB0}
Collector-Emitter Voltage	- V _{CE0}
Emitter-Base Voltage	- V _{EB0}
Collector Current	- I _C
Base Current	- I _B
Total Power Dissipation (T _C ≤ 25°C)	P _{tot}
Junction Temperature	T _j
Storage Temperature Range	T _{stg}

	2N 6124	2N 6125	2N 6126
- V _{CB0}	45V	60V	80V
- V _{CE0}	45V	60V	80V
- V _{EB0}		5V	
- I _C		4A	
- I _B		1A	
P _{tot}		40W	
T _j		150°C	
T _{stg}		-55 to +150°C	

THERMAL RESISTANCE

Junction to Case

θ_{jc} 3.12°C/W max.

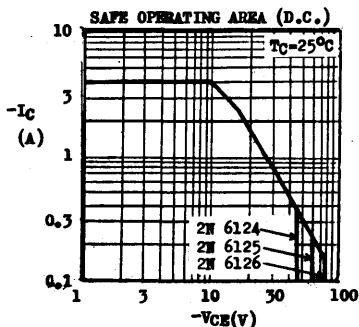
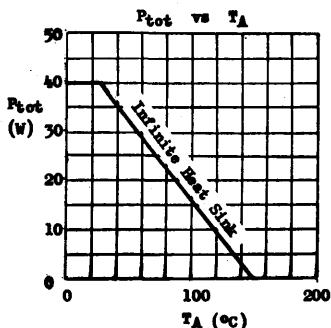

2N6124 2N6125 2N6126

ELECTRICAL CHARACTERISTICS ($T_A=25^\circ\text{C}$ unless otherwise noted)

PARAMETER	SYMBOL	MIN	TYP	MAX	UNIT	TEST CONDITIONS
Collector-Emitter Breakdown Voltage	$-V_{CE0}^*$					$-I_C=0.1\text{A}$ $I_B=0$
2N 6124		45			V	
2N 6125		60			V	
2N 6126		80			V	
Collector-Base Cutoff Current	$-I_{CB0}$			0.1	mA	$V_{CB}=V_{CE0}$ $I_B=0$
Collector-Emitter Cutoff Current	$-I_{CE0}$			1	mA	$V_{CB}=V_{CE0}$ $I_B=0$
Collector-Emitter Cutoff Current	$-I_{CEV}$			0.1	mA	$V_{CB}=V_{CE0}$ $-V_{EB}=-1.5\text{V}$
				2	mA	$V_{CB}=V_{CE0}$ $-V_{EB}=-1.5\text{V}$ $T_C=125^\circ\text{C}$
Emitter-Base Cutoff Current	$-I_{EB0}$			1	mA	$-V_{EB}=5\text{V}$ $I_C=0$
Collector-Emitter Saturation Voltage	$-V_{CE(sat)}^*$	0.35	0.6		V	$-I_C=1.5\text{A}$ $-I_B=0.15\text{A}$
			1.4		V	$-I_C=4\text{A}$ $-I_B=1\text{A}$
Base-Emitter Voltage	$-V_{BE}^*$		0.9	1.2	V	$-I_C=1.5\text{A}$ $-V_{CB}=2\text{V}$
D.C. Current Gain	H_{FE}^*					
2N 6124, 2N 6125		25	100			$-I_C=1.5\text{A}$ $-V_{CB}=2\text{V}$
2N 6126		20	80			$-I_C=1.5\text{A}$ $-V_{CB}=2\text{V}$
2N 6124, 2N 6125	H_{FE}^*	10				$-I_C=4\text{A}$ $-V_{CB}=2\text{V}$
2N 6126		7				$-I_C=4\text{A}$ $-V_{CB}=2\text{V}$
Current Gain-Bandwidth Product	f_T	2.5			MHz	$-I_C=1\text{A}$ $-V_{CB}=4\text{V}$
Small Signal Current Gain	h_{fe}	25				$-I_C=0.1\text{A}$ $-V_{CB}=2\text{V}$ $f=1\text{kHz}$

* Pulse Test : Pulse Width=0.3ms, Duty Cycle=1%

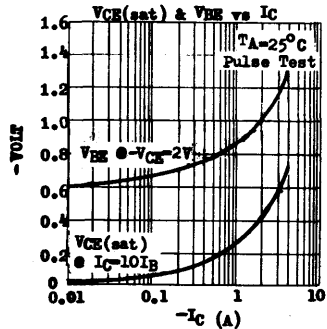
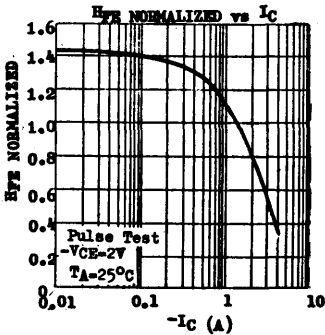

12.77.0670E

2N6129 2N6130 2N6131

NPN SILICON EPITAXIAL BASE POWER TRANSISTORS

THE 2N 6129, 2N 6130 AND 2N 6131 ARE NPN SILICON EPITAXIAL BASE POWER TRANSISTORS DESIGNED FOR SWITCHING, DRIVER AND OUTPUT STAGES IN AUDIO AMPLIFIERS. THE 2N 6129, 2N 6130, 2N 6131 ARE COMPLEMENTARY TO 2N 6132, 2N 6133, 2N 6134 RESPECTIVELY.

CASE TO-220B



ABSOLUTE MAXIMUM RATINGS

Collector-Base Voltage
 Collector-Emitter Voltage
 Emitter-Base Voltage
 Collector Current
 Base Current
 Total Power Dissipation ($T_C \leq 25^\circ\text{C}$)
 Junction Temperature
 Storage Temperature Range

	2N 6129	2N 6130	2N 6131
V_{CBO}	40V	60V	80V
V_{CEO}	40V	60V	80V
V_{EBO}		5V	
I_C		7A	
I_B		3A	
P_{tot}		50W	
T_j		150°C	
T_{stg}		-55 to +150°C	

THERMAL RESISTANCE

Junction to Case

θ_{jc} 2.5°C/W max.

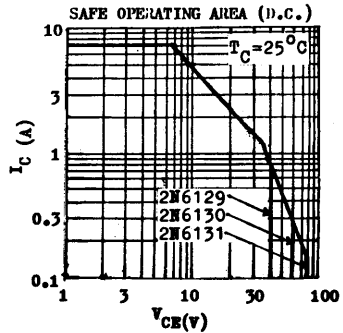
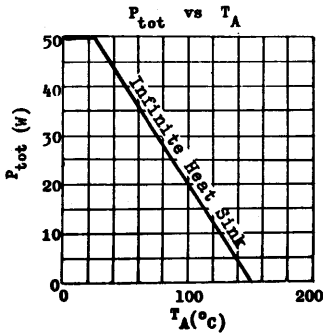

2N6129 2N6130 2N6131

ELECTRICAL CHARACTERISTICS ($T_A=25^\circ\text{C}$ unless otherwise noted)

PARAMETER	SYMBOL	MIN	TYP	MAX	UNIT	TEST CONDITIONS
Collector-Emitter Breakdown Voltage 2N 6129 2N 6130 2N 6131	V_{CBO}^*	40 60 80			V V V	$I_C=0.1\text{A}$ $I_B=0$
Collector-Base Cutoff Current	I_{CBO}			0.1	mA	$V_{CB}=V_{CBO}$ $I_E=0$
Collector-Base Cutoff Current	I_{CEO}			2	mA	$V_{CB}=V_{CBO}$ $I_B=0$
Collector-Emitter Cutoff Current	I_{CEV}			2	mA	$V_{CB}=V_{CBO}$ $V_{EB}=1.5\text{V}$ $T_C=125^\circ\text{C}$
Emitter-Base Cutoff Current	I_{EB0}			1	mA	$V_{EB}=5\text{V}$ $I_C=0$
Collector-Emitter Saturation Voltage 2N 6129, 2N 6130 2N 6131	$V_{CE(sat)}^*$			1.4 2.0	V V	$I_C=7\text{A}$ $I_B=3\text{A}$
Base-Emitter Voltage	V_{BE}^*		0.95	2.0	V	$I_C=2.5\text{A}$ $V_{CE}=4\text{V}$
D.C. Current Gain All types 2N 6129, 2N 6130 2N 6131	h_{FE}^*	20 7 5		100		$I_C=2.5\text{A}$ $V_{CE}=4\text{V}$ $I_C=7\text{A}$ $V_{CE}=4\text{V}$ $I_C=7\text{A}$ $V_{CE}=4\text{V}$
Current Gain-Bandwidth Product	f_T	2.5			MHz	$I_C=1\text{A}$ $V_{CE}=4\text{V}$
Small Signal Current Gain	h_{fe}	25				$I_C=0.1\text{A}$ $V_{CE}=4\text{V}$ $f=1\text{kHz}$

* Pulse Test : Pulse Width=0.3ms, Duty Cycle=1%

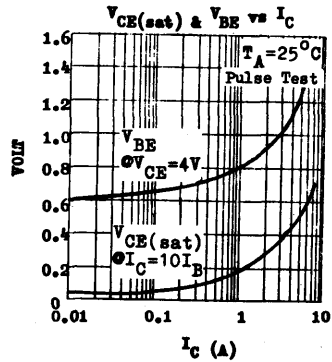
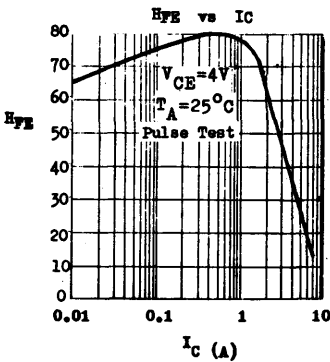

2N6132 2N6133 2N6134

PNP SILICON EPITAXIAL BASE POWER TRANSISTORS

THE 2N 6132, 2N 6133 AND 2N 6134 ARE PNP SILICON EPITAXIAL BASE POWER TRANSISTORS DESIGNED FOR SWITCHING, DRIVER AND OUTPUT STAGES IN AUDIO AMPLIFIERS. THE 2N 6132, 2N 6133 AND 2N 6134 ARE COMPLEMENTARY TO 2N 6129, 2N 6130 AND 2N 6131 RESPECTIVELY.

CASE TO-220B



ABSOLUTE MAXIMUM RATINGS

Collector-Base Voltage
 Collector-Emitter Voltage
 Emitter-Base Voltage
 Collector Current
 Base Current
 Total Power Dissipation ($T_C \leq 25^\circ\text{C}$)
 Junction Temperature
 Storage Temperature Range

	2N 6132	2N 6133	2N 6134
$-V_{CB0}$	40V	60V	80V
$-V_{CE0}$	40V	60V	80V
$-V_{EB0}$		5V	
$-I_C$		7A	
$-I_B$		3A	
P_{tot}		50W	
T_j		150°C	
T_{stg}		-55 to +150°C	

THERMAL RESISTANCE

Junction to Case

θ_{jc} 2.5°C/W max.

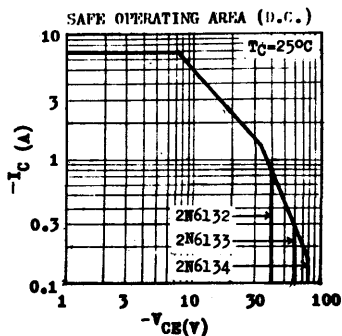
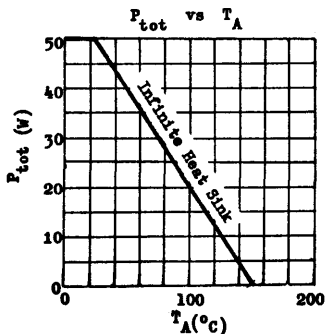

2N6132 2N6133 2N6134

ELECTRICAL CHARACTERISTICS ($T_A=25^\circ\text{C}$ unless otherwise noted)

PARAMETER	SYMBOL	MIN	TYP	MAX	UNIT	TEST CONDITIONS
Collector-Emitter Breakdown Voltage 2N 6132 2N 6133 2N 6134	$-V_{CE0}$ *	40 60 80			V V V	$-I_C=0.1A$ $I_B=0$
Collector-Base Cutoff Current	$-I_{CB0}$		0.5		mA	$V_{CB}=V_{CE0}$ $I_B=0$
Collector-Emitter Cutoff Current	$-I_{CE0}$		2		mA	$V_{CB}=V_{CE0}$ $I_B=0$
Collector-Emitter Cutoff Current	$-I_{CEV}$		2		mA	$V_{CB}=V_{CE0}$ $-V_{EB}=1.5V$ $T_C=125^\circ\text{C}$
Emitter-Base Cutoff Current	$-I_{EB0}$		1		mA	$-V_{EB}=5V$ $I_C=0$
Collector-Emitter Saturation Voltage 2N 6132, 2N 6133 2N 6134	$-V_{CE(sat)}$ *		1.4 1.8		V V	$-I_C=7A$ $-I_B=3A$
Base-Emitter Voltage	$-V_{BE}$ *	0.97	2		V	$-I_C=2.5A$ $-V_{CE}=4V$
D.C. Current Gain All types 2N 6132, 2N 6133 2N 6134	H_{FE} *	20 7 5	100			$-I_C=2.5A$ $-V_{CE}=4V$ $-I_C=7A$ $-V_{CE}=4V$ $-I_C=7A$ $-V_{CE}=4V$
Current Gain-Bandwidth Product	f_T	2.5			MHz	$-I_C=1A$ $-V_{CE}=4V$
Small Signal Current Gain	h_{fe}	25				$-I_C=0.1A$ $-V_{CE}=4V$ $f=1\text{kHz}$

* Pulse Test : Pulse Width=0.3ms, Duty Cycle=1%

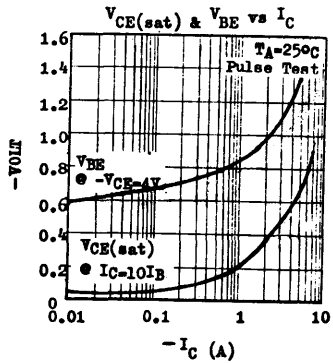
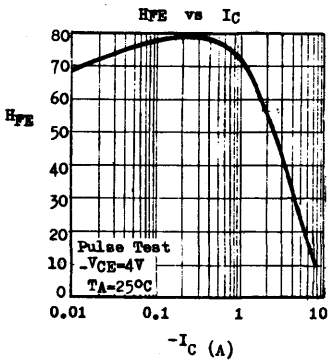

2N6218 through 2N6221

NPN SILICON GENERAL PURPOSE HIGH VOLTAGE TRANSISTORS

THE 2N6218 THROUGH 2N6221 ARE NPN SILICON PLANAR TRANSISTORS INTENDED FOR USE IN TV, NIXIE-NEON TUBE AND OTHER GENERAL HIGH VOLTAGE APPLICATIONS. THE DEVICES ARE SUPPLIED IN CASE TO-92F WITH OPTIONAL X-67 HEAT SINK.

CASE TO-92F X-67 HEAT SINK

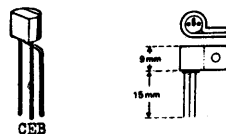

ABSOLUTE MAXIMUM RATINGS

	2N6218	2N6219	2N6220	2N6221	
Collector-Base Voltage	VCBO	300V	250V	200V	150V
Collector-Emitter Voltage	VCBO	300V	250V	200V	150V
Emitter-Base Voltage	VEBO	5V	5V	5V	5V
Collector Current	IC		50mA		
Collector Peak Current	ICM		100mA		
Total Power Dissipation @ TC ≤ 25°C	Ptot		1.5W		
With X-67 Heat Sink @ TA ≤ 25°C			800mW		
No Heat Sink @ TA ≤ 25°C			625mW **		
Operating Junction & Storage Temperature	Tj, Tstg		-55 to 150°C		

** 0.5W in JEDEC registration.

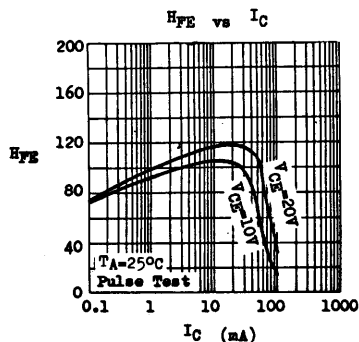
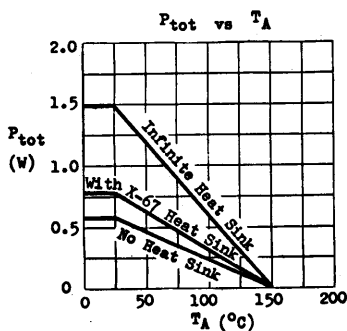

2N6218 through 2N6221

ELECTRICAL CHARACTERISTICS (TA=25°C unless otherwise noted)

PARAMETER	SYMBOL	MIN	MAX	UNIT	TEST CONDITIONS
Collector-Base Breakdown Voltage	BV _{CB0}	Note 1		V	I _C =0.1mA I _B =0
Collector-Emitter Breakdown Voltage	LV _{CE0}	Note 1		V	I _C =10mA I _B =0 (Pulsed)
Emitter-Base Breakdown Voltage	BV _{EB0}	5		V	I _E =0.1mA I _C =0
Collector Cutoff Current	I _{CBO}				
2N6218			0.5	μA	V _{CB} =250V I _E =0
2N6219			1	μA	V _{CB} =200V I _E =0
2N6220			1	μA	V _{CB} =150V I _E =0
2N6221			1	μA	V _{CB} =100V I _E =0
Collector-Emitter Saturation Voltage	V _{CE(sat)}				
2N6218,9			1	V	I _C =10mA I _B =1mA
2N6220,1			2	V	I _C =20mA I _B =2mA
Base-Emitter Saturation Voltage	V _{BE(sat)}				
2N6218,9		0.6	0.75	V	I _C =10mA I _B =1mA
2N6220,1		0.65	0.85	V	I _C =20mA I _B =2mA
Base-Emitter Voltage	V _{BE}	0.55	0.75	V	I _C =20mA V _{CE} =10V
D.C. Current Gain	HFE	10			I _C =2mA V _{CE} =10V
		20			I _C =20mA V _{CE} =10V
Current Gain-Bandwidth Product	f _T	50		MHz	I _C =10mA V _{CE} =10V
Collector-Base Capacitance	C _{cb}		5	pF	V _{CB} =10V I _E =0 f=1MHz
Emitter-Base Capacitance	C _{eb}		70	pF	V _{EB} =0.5V I _C =0 f=1MHz
Small Signal Current Gain	h _{fe}	20	300		I _C =20mA V _{CE} =10V f=1kHz

Note 1 : equal to the values of V_{CB0} & V_{CE0} ratings.

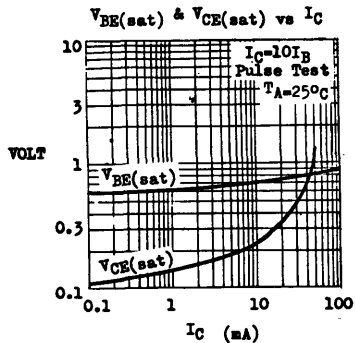
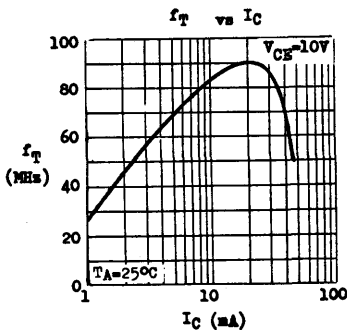

2N6288 2N6290 2N6292

NPN SILICON EPITAXIAL BASE POWER TRANSISTORS

THE 2N 6288, 2N 6290 AND 2N 6292 ARE NPN SILICON EPITAXIAL BASE POWER TRANSISTORS DESIGNED FOR SWITCHING, DRIVER AND OUTPUT STAGES IN AUDIO AMPLIFIERS. THE 2N 6288, 2N 6290, 2N 6292 ARE COMPLEMENTARY TO 2N 6111, 2N 6109, 2N 6107 RESPECTIVELY.

CASE TO-220B



ABSOLUTE MAXIMUM RATINGS

Collector-Base Voltage
 Collector-Emitter Voltage
 Emitter-Base Voltage
 Collector Current
 Base Current
 Total Power Dissipation
 @ $T_C < 25^\circ\text{C}$
 @ $T_A < 25^\circ\text{C}$
 Junction Temperature
 Storage Temperature Range

	2N 6288	2N 6290	2N 6292
V_{CBO}	40V	60V	80V
V_{CEO}	30V	50V	70V
V_{EB0}		5V	
I_C		7A	
I_B		3A	
P_{tot}		40W	
		1.8W	
T_J		150°C	
T_{stg}		-55 to +150°C	

THERMAL RESISTANCE

Junction to Case

θ_{jc} 3.12°C/W max.

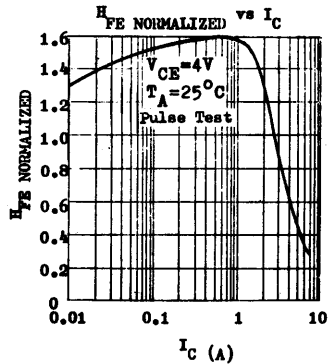
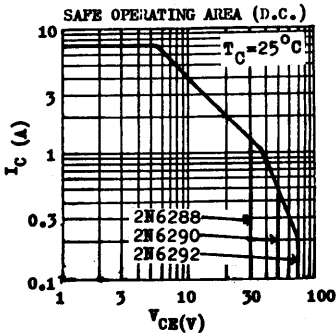

2N6288 2N6290 2N6292

ELECTRICAL CHARACTERISTICS ($T_A=25^\circ\text{C}$ unless otherwise noted)

PARAMETER	SYMBOL	MIN	TYP	MAX	UNIT	TEST CONDITIONS
Collector-Emitter Breakdown Voltage 2N 6288 2N 6290 2N 6292	V_{CE0}^*	30 50 70			V V V	$I_C=0.1A$ $I_B=0$
Collector-Emitter Breakdown Voltage 2N 6288 2N 6290 2N 6292	V_{CEB}^*	40 60 80			V V V	$I_C=0.1A$ $R_{BB}=100\Omega$
Collector-Emitter Cutoff Current 2N 6288 2N 6290 2N 6292	I_{CE0}		1 1 1		mA mA mA	$V_{CE}=20V$ $I_B=0$ $V_{CE}=40V$ $I_B=0$ $V_{CE}=60V$ $I_B=0$
Collector-Emitter Cutoff Current 2N 6288 2N 6290 2N 6292	I_{CEB}		0.1 0.1 0.1		mA mA mA	$V_{CE}=35V$ $R_{BB}=100\Omega$ $V_{CE}=55V$ $R_{BB}=100\Omega$ $V_{CE}=75V$ $R_{BB}=100\Omega$
Collector-Emitter Cutoff Current 2N 6288 2N 6290 2N 6292	I_{CEB}		2 2 2		mA mA mA	$V_{CE}=30V$ $R_{BB}=100\Omega$ $T_C=150^\circ\text{C}$ $V_{CE}=50V$ $R_{BB}=100\Omega$ $T_C=150^\circ\text{C}$ $V_{CE}=70V$ $R_{BB}=100\Omega$ $T_C=150^\circ\text{C}$
Collector-Emitter Cutoff Current 2N 6288 2N 6290 2N 6292	I_{CEV}		0.1 0.1 0.1		mA mA mA	$V_{CE}=37.5V$ $V_{EB}=1.5V$ $V_{CE}=56V$ $V_{EB}=1.5V$ $V_{CE}=75V$ $V_{EB}=1.5V$
Collector-Emitter Cutoff Current 2N 6288 2N 6290 2N 6292	I_{CEV}		2 2 2		mA mA mA	$V_{CE}=30V$ $V_{EB}=1.5V$ $T_C=150^\circ\text{C}$ $V_{CE}=50V$ $V_{EB}=1.5V$ $T_C=150^\circ\text{C}$ $V_{CE}=70V$ $V_{EB}=1.5V$ $T_C=150^\circ\text{C}$
Emitter-Base Cutoff Current	I_{EB0}		1		mA	$V_{EB}=5V$ $I_C=0$
Collector-Emitter Saturation Voltage 2N 6288 2N 6290 2N 6292 All types	$V_{CE(sat)}^*$		0.35 0.3 0.3 3.5	1 1 1 V	V V V V	$I_C=3A$ $I_B=0.3A$ $I_C=2.5A$ $I_B=0.25A$ $I_C=2A$ $I_B=0.2A$ $I_C=7A$ $I_B=3A$
Base-Emitter Voltage 2N 6288 2N 6290 2N 6292 All types	V_{BE}^*		1 0.95 0.9 3	1.5 1.5 1.5 V	V V V V	$I_C=3A$ $V_{CE}=4V$ $I_C=2.5A$ $V_{CE}=4V$ $I_C=2A$ $V_{CE}=4V$ $I_C=7A$ $V_{CE}=4V$
D.C. Current Gain 2N 6288 2N 6290 2N 6292 All types	h_{FE}^*	30 30 30 2.3	150 150 150			$I_C=3A$ $V_{CE}=4V$ $I_C=2.5A$ $V_{CE}=4V$ $I_C=2A$ $V_{CE}=4V$ $I_C=7A$ $V_{CE}=4V$
Current Gain-Bandwidth Product	f_T	4			MHz	$I_C=0.5A$ $V_{CE}=4V$
Collector-Base Capacitance	C_{ob}		250		pF	$V_{CB}=10V$ $I_B=0$ $f=1\text{MHz}$
Small Signal Current Gain	h_{fe}	20				$I_C=0.5A$ $V_{CE}=4V$ $f=50\text{KHz}$

* Pulse Test : Pulse Width=0.3ms, Duty Cycle=1%

12.77.8500E

2N6473 2N6474 2N6475 2N6476

COMPLEMENTARY SILICON EPITAXIAL BASE AF POWER TRANSISTORS

THE 2N6473, 2N6474 (NPN) AND 2N6475 2N6476 (PNP) ARE COMPLEMENTARY SILICON EPITAXIAL BASE POWER TRANSISTORS DESIGN FOR SWITCHING, DRIVER AND OUTPUT STAGES IN AUDIO AMPLIFIERS. THEY FEATURE HIGH COLLECTOR-EMITTER BREAK-DOWN VOLTAGE.

CASE TO-220B



BCE

ABSOLUTE MAXIMUM RATINGS

For p-n-p devices, voltage and current values are negative.

Collector-Base Voltage
 Collector-Emitter Voltage ($R_{BE} \leq 100\Omega$)
 Collector-Emitter Voltage ($I_B=0$)
 Emitter-Base Voltage
 Collector Current
 Total Power Dissipation ($T_C \leq 25^\circ C$)
 ($T_A \leq 25^\circ C$)
 Operating Junction & Storage Temperature

	2N6473(NPN) 2N6475(PNP)	2N6474(NPN) 2N6476(PNP)
V _{CB0}	110V	130V
V _{CER}	110V	130V
V _{CEO}	100V	120V
V _{EB0}	5V	5V
I _C	4A	4A
P _{tot}	40W	40W
	1.8W	1.8W
T _j , T _{stg}	-55 to 150°C	

THERMAL RESISTANCE

Junction to Case
 Junction to Ambient

Q _{jc}	3.13°C/W max.
Q _{ja}	70°C/W max.

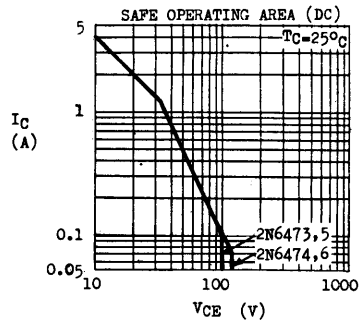
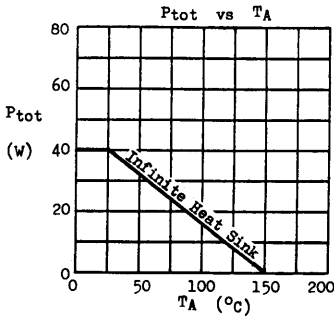

2N6473 2N6474 2N6475 2N6476

ELECTRICAL CHARACTERISTICS (TA=25°C unless otherwise noted)

PARAMETER	SYMBOL	2N6473 (NPN) 2N6475 (PNP)		2N6474 (NPN) 2N6476 (PNP)		UNIT	TEST CONDITIONS
		MIN	MAX	MIN	MAX		
Collector-Emitter Breakdown Voltage	LV _{CER} *	110		130		V	I _C =0.1A R _{BE} =100Ω
Collector-Emitter Breakdown Voltage	LV _{CBO} *	100		120		V	I _C =0.1A I _B =0
Collector Cutoff Current	I _{CER}		0.1			mA	V _{CE} =100V R _{BE} =100Ω
					0.1	mA	V _{CE} =120V R _{BE} =100Ω
Collector Cutoff Current (T _C =100°C)	I _{CER}		2			mA	V _{CE} =100V R _{BE} =100Ω
					2	mA	V _{CE} =120V R _{BE} =100Ω
Collector Cutoff Current	I _{CEV}		0.1			mA	V _{CE} =100V V _{EB} =1.5V
					0.1	mA	V _{CE} =120V V _{EB} =1.5V
Collector Cutoff Current (T _C =100°C)	I _{CEV}		2			mA	V _{CE} =100V V _{EB} =1.5V
					2	mA	V _{CE} =120V V _{EB} =1.5V
Collector Cutoff Current	I _{CBO}		1			mA	V _{CE} =50V I _B =0
					1	mA	V _{CE} =60V I _B =0
Emitter Cutoff Current	I _{EBO}		1			mA	V _{EB} =5V I _C =0
Collector-Emitter Saturation Voltage	V _{CE(sat)} *	1.2		1.2		V	I _C =1.5A I _B =0.15A
		2.5		2.5		V	I _C =4A I _B =2A
Base-Emitter Voltage	V _{BE} *	2		2		V	I _C =1.5A V _{CE} =4V
		3.5		3.5		V	I _C =4A V _{CE} =2.5V
D.C. Current Gain	h _{FE} *	15	150	15	150		I _C =1.5A V _{CE} =4V
		2		2			I _C =4A V _{CE} =2.5V
Current Gain-Bandwidth Product	f _T	4		4		MHz	I _C =0.5A V _{CE} =4V
2N6473,4 only		10		10		MHz	
Collector-Base Capacitance	C _{ob}		250		250	pF	V _{CB} =10V I _B =0 f=1MHz
Small Signal Current Gain	h _{fe}	20		20			I _C =0.5A V _{CE} =4V f=50KHz

* Pulse Test : Pulse Width=0.3ms, Duty Cycle=1%

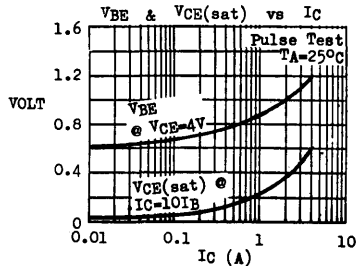
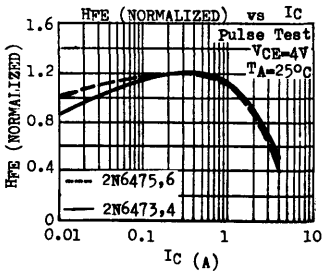

2.78.8500F.0850F

2SA473 2SC1173

PNP NPN SILICON PLANAR EPITAXIAL POWER TRANSISTORS

THE 2SA 473 (PNP) AND 2SC 1173 (NPN) ARE SILICON PLANAR EPITAXIAL COMPLEMENTARY PAIR SPECIALLY DESIGNED FOR 5-WATT AUDIO AMPLIFIER OUTPUT APPLICATIONS. THEY ARE ALSO SUITABLE FOR SWITCHING UP TO 3A COLLECTOR CURRENT.

CASE TO-220B



ABSOLUTE MAXIMUM RATINGS

For pnp device, voltage and current values are negative

Collector-Base Voltage	V_{CBO}	30V
Collector-Emitter Voltage	V_{CEO}	30V
Emitter-Base Voltage	V_{EBO}	5V
Collector Current	I_C	3A
Collector Peak Current ($t \leq 10\text{ms}$)	I_{CM}	6A
Total Power Dissipation ($T_C \leq 25^\circ\text{C}$)	P_{tot}	10W
Junction Temperature	T_j	150°C
Storage Temperature Range	T_{stg}	-55 to +150°C

ELECTRICAL CHARACTERISTICS ($T_A = 25^\circ\text{C}$ unless otherwise noted)

PARAMETER	SYMBOL	MIN	TYP	MAX	UNIT	TEST CONDITIONS
Collector-Base Breakdown Voltage	BV_{CBO}	30			V	$I_C = 0.1\text{mA}$ $I_E = 0$
Collector-Emitter Breakdown Voltage	LV_{CEO}^*	30			V	$I_C = 10\text{mA}$ $I_B = 0$
Collector Cutoff Current	I_{CBO}			1.0	μA	$V_{CB} = 20\text{V}$ $I_E = 0$
Emitter Cutoff Current	I_{EBO}			1.0	μA	$V_{EB} = 5\text{V}$ $I_C = 0$
Collector-Emitter Saturation Voltage	$V_{CE(sat)}^*$			0.8	V	$I_C = 2\text{A}$ $I_B = 0.2\text{A}$
Base-Emitter Voltage	V_{BE}^*			1.0	V	$I_C = 0.5\text{A}$ $V_{CE} = 2\text{V}$
D.C. Current Gain (Note)	$H_{FE 1}^*$	40		400		$I_C = 0.5\text{A}$ $V_{CE} = 2\text{V}$
	$H_{FE 2}^*$	25				$I_C = 2.5\text{A}$ $V_{CE} = 2\text{V}$
Current Gain-Bandwidth Product	f_T		100		MHz	$I_C = 0.1\text{A}$ $V_{CE} = 10\text{V}$

* Pulse Test ; Pulse Width=0.3ms, Duty Cycle=1%

Note : H_{FE} is classified as follows.

Group R : 40-80

Group O : 70-140

Group Y : 120-240

Group G : 200-400

2SA473 2SC1173

TYPICAL CHARACTERISTICS

($T_A=25^\circ\text{C}$ unless otherwise noted)

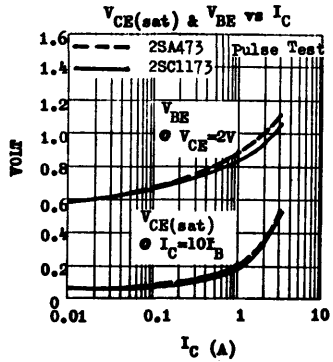
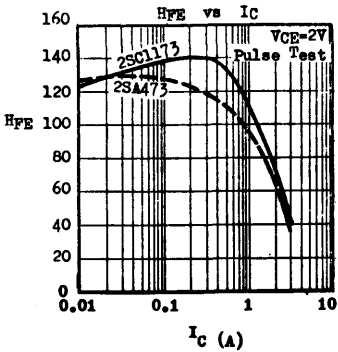
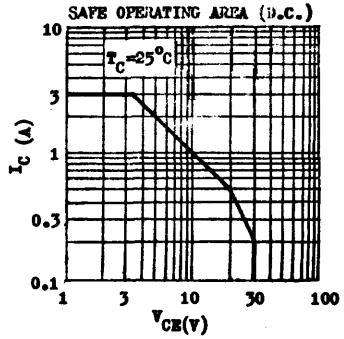
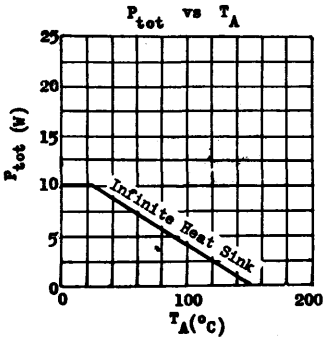

2SA489 2SB604 2SB596

PNP SILICON EPITAXIAL BASE POWER TRANSISTORS

THE 2SA489, 2SB604, 2SB596 ARE PNP SILICON EPITAXIAL BASE POWER TRANSISTORS DESIGNED FOR 20 TO 25W AUDIO AMPLIFIER OUTPUTS AND SWITCHING APPLICATIONS UP TO 4A COLLECTOR CURRENT. THE 2SA489, 2SB604 AND 2SB596 ARE COMPLEMENTARY TO 2SC789, 2SD570 AND 2SD526 RESPECTIVELY.

CASE TO-220B



ABSOLUTE MAXIMUM RATINGS

		2SA489	2SB604	2SB596
Collector-Base Voltage	$-V_{CB0}$	70V	70V	80V
Collector-Emitter Voltage	$-V_{CE0}$	60V	70V	80V
Emitter-Base Voltage	$-V_{EB0}$		5V	
Collector Current	$-I_C$		4A	
Collector Peak Current ($t \leq 10\text{ms}$)	$-I_{CM}$		8A	
Total Power Dissipation ($T_C \leq 25^\circ\text{C}$)	P_{tot}		30W	
Junction Temperature	T_j		150°C	
Storage Temperature Range	T_{stg}		-55 to +150°C	

THERMAL RESISTANCE

Junction to Case	θ_{jc}	4.17°C/W	max.
------------------	---------------	----------	------

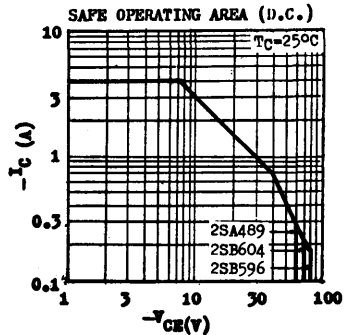
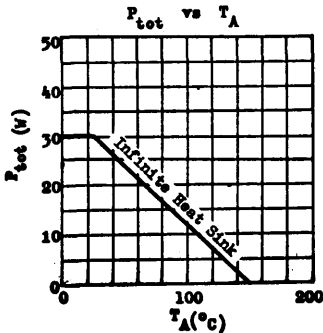

2SA489 2SB604 2SB596

ELECTRICAL CHARACTERISTICS ($T_A=25^\circ\text{C}$ unless otherwise noted)

PARAMETER	SYMBOL	MIN	TYP	MAX	UNIT	TEST CONDITIONS
Collector-Base Breakdown Voltage	$-V_{CB0}$					$-I_C=0.1\text{mA}$ $I_B=0$
2SA489		70			V	
2SB604		70			V	
2SB596		80			V	
Collector-Emitter Breakdown Voltage	$-V_{CE0}^*$					$-I_C=100\text{mA}$ $I_B=0$
2SA489		60			V	
2SB604		70			V	
2SB596		80			V	
Collector Cutoff Current	$-I_{CBO}$					
2SA489				30	μA	$-V_{CB}=50\text{V}$ $I_E=0$
2SB604				30	μA	$-V_{CB}=50\text{V}$ $I_E=0$
2SB596				30	μA	$-V_{CB}=80\text{V}$ $I_E=0$
Emitter Cutoff Current	$-I_{EBO}$			100	μA	$-V_{EB}=5\text{V}$ $I_C=0$
Collector-Emitter Saturation Voltage	$-V_{CE(sat)}^*$	0.4	1.5		V	$-I_C=3\text{A}$ $-I_B=0.3\text{A}$
Base-Emitter Voltage	$-V_{BE}^*$					
2SA489		1.0	1.5		V	$-I_C=2.5\text{A}$ $-V_{CE}=5\text{V}$
2SB604		1.07	1.5		V	$-I_C=3\text{A}$ $-V_{CE}=5\text{V}$
2SB596		1.07	1.5		V	$-I_C=3\text{A}$ $-V_{CE}=5\text{V}$
D.C. Current Gain (note)	$H_{FE} 1^*$	40		240		$-I_C=0.5\text{A}$ $-V_{CE}=5\text{V}$
	$H_{FE} 2^*$	15				$-I_C=3\text{A}$ $-V_{CE}=5\text{V}$
Current Gain-Bandwidth Product	f_T	3			MHz	$-I_C=0.5\text{A}$ $-V_{CE}=5\text{V}$

* Pulse Test : Pulse Width=0.3ms, Duty Cycle=1%

note: $H_{FE} 1$ is classified as follows. Group R : 40-80 Group O : 70-140
 Group Y : 120-240

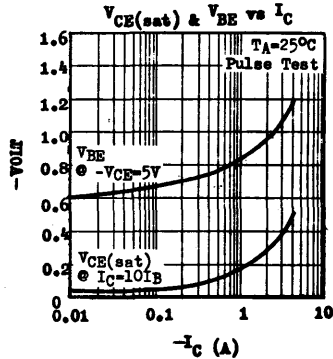
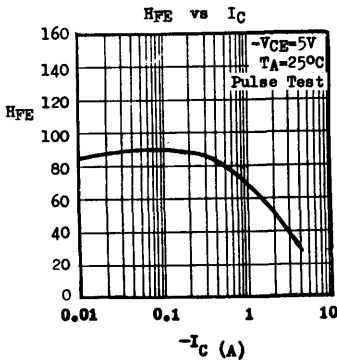

2SA490 2SC790

PNP NPN SILICON EPITAXIAL BASE POWER TRANSISTORS

THE 2SA490 (PNP) AND 2SC790 (NPN) ARE SILICON EPITAXIAL BASE COMPLEMENTARY PAIR SPECIALLY DESIGNED FOR 10-WATT AUDIO AMPLIFIER OUTPUT APPLICATIONS. THEY ARE ALSO SUITABLE FOR SWITCHING UP TO 3A COLLECTOR CURRENT.

CASE TO-220B



BCE

ABSOLUTE MAXIMUM RATINGS

For p-p device, voltage and current values are negative.

Collector-Base Voltage	V _{CB0}	50V
Collector-Emitter Voltage	V _{CE0}	40V
Emitter-Base Voltage	V _{EB0}	5V
Collector Current	I _C	3A
Collector Peak Current (t ≤ 10ms)	I _{CM}	6A
Total Power Dissipation (T _C ≤ 25°C)	P _{tot}	25W
Junction Temperature	T _j	150°C
Storage Temperature Range	T _{stg}	-55 to +150°C

ELECTRICAL CHARACTERISTICS (T_A = 25°C unless otherwise noted)

PARAMETER	SYMBOL	MIN	TYP	MAX	UNIT	TEST CONDITIONS
Collector-Base Breakdown Voltage	BV _{CB0}	50			V	I _C = 0.1mA I _E = 0
Collector-Emitter Breakdown Voltage	LV _{CE0} *	40			V	I _C = 50mA I _B = 0
Collector Cutoff Current	I _{CB0}			20	μA	V _{CB} = 30V I _E = 0
Emitter Cutoff Current	I _{EB0}			100	μA	V _{EB} = 5V I _C = 0
Collector-Emitter Saturation Voltage	V _{CE(sat)} *		0.4	1.4	V	I _C = 2A I _B = 0.2A
Base-Emitter Voltage	V _{BE} *		1.0	1.8	V	I _C = 2A V _{CE} = 2V
D.C. Current Gain (note)	H _{FE} 1 *		40	240		I _C = 0.5A V _{CE} = 2V
	H _{FE} 2 *		13			I _C = 2A V _{CE} = 2V
Current Gain-Bandwidth Product	f _T		3		MHz	I _C = 0.5A V _{CE} = 2V

* Pulse Test : Pulse Width = 0.3ms, Duty Cycle = 1%

Note : H_{FE} 1 is classified as follows : Group R : 40-80
Group Y : 120-240

Group O : 70-140

2SA490 2SC790

TYPICAL CHARACTERISTICS

($T_A=25^\circ\text{C}$ unless otherwise noted)

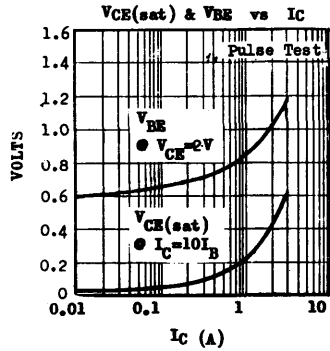
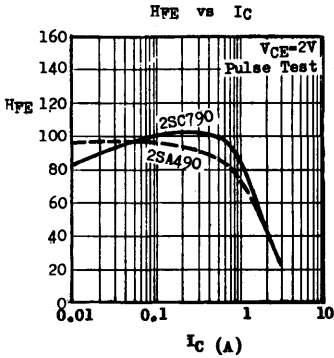
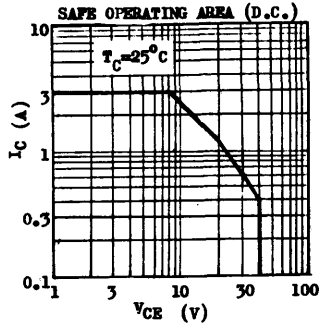
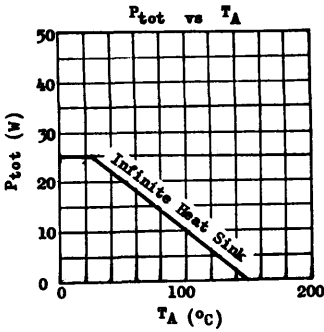

12.77.0870E.8700E

2SA539 2SC815

COMPLEMENTARY SILICON GENERAL PURPOSE AF AMPLIFIERS

THE 2SA539 (PNP) ARE 2SC815 (NPN) ARE SILICON PLANAR EPITAXIAL TRANSISTORS FOR USE IN AF AMPLIFIERS AND DRIVERS, AS WELL AS FOR UNIVERSAL SWITCHING APPLICATIONS.

CASE TO-92B



ECB

ABSOLUTE MAXIMUM RATINGS For p-n-p device, voltage and current values are negative.

Collector-Base Voltage	V _{CB0}	60V
Collector-Emitter Voltage	V _{CE0}	45V
Emitter-Base Voltage	V _{EB0}	5V
Collector Current	I _C	200mA
Collector Peak Current	I _{CM}	500mA
Total Power Dissipation (T _A ≤ 25°C)	P _{tot}	250mW derate 2.5mW/°C above 25°C
Operating Junction & Storage Temperature	T _j , T _{stg}	-55 to 125°C

ELECTRICAL CHARACTERISTICS (T_A=25°C unless otherwise noted)

PARAMETER	SYMBOL	MIN	TYP	MAX	UNIT	TEST CONDITIONS
Collector-Emitter Breakdown Voltage	V _{CE0} *	45			V	I _C =10mA I _B =0
Collector Cutoff Current	I _{CB0}			0.1	μA	V _{CE} =45V I _B =0
Emitter Cutoff Current	I _{EB0}			0.1	μA	V _{EB} =3V I _C =0
Collector-Emitter Saturation Voltage	V _{CE(sat)} *	0.18	0.5		V	I _C =150mA I _B =15mA
Base-Emitter Saturation Voltage	V _{BE(sat)} *	0.88	1.2		V	I _C =150mA I _B =15mA
Base-Emitter Voltage	V _{BE}	0.6	0.68	0.9	V	I _C =10mA V _{CE} =10V
D.C. Current Gain (Note 1)	HFE 1 *	50	120	232		I _C =50mA V _{CE} =1V
	HFE 2 *	30	100			I _C =150mA V _{CE} =2V
Current Gain-Bandwidth Product	f _T	100	160		MHz	I _C =10mA V _{CE} =10V
Collector-Base Capacitance	C _{ob}				pF	V _{CB} =10V I _B =0
			4.5	8	pF	f=1MHz
			5.5		pF	

* Pulse Test : Pulse Width=0.3mS, Duty Cycle=1%

Note 1 : HFE 1 is classified as follows.

Group M : 50-94

Group L : 80-150

Group K : 125-232

TYPICAL CHARACTERISTICS ($T_A=25^\circ\text{C}$ unless otherwise noted)

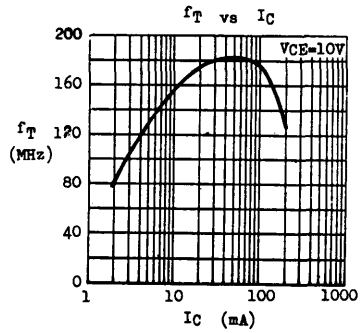
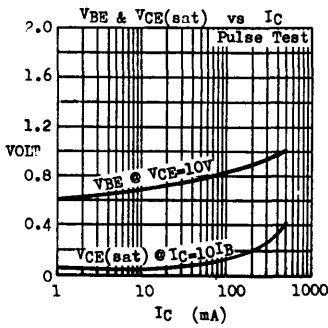
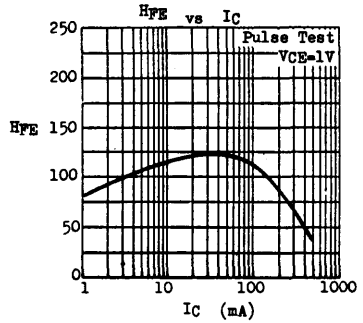
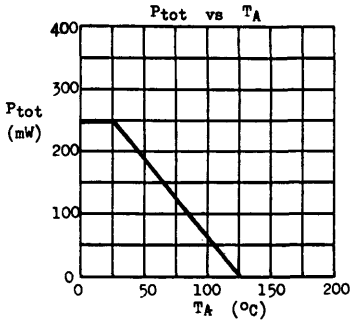

2SA564 2SA564A 2SC828 2SC828A

COMPLEMENTARY SILICON AF SMALL SIGNAL TRANSISTORS

THE 2SA564, 2SA564A (PNP) AND 2SC828, 2SC828A (NPN) ARE COMPLEMENTARY SILICON PLANAR EPITAXIAL TRANSISTORS FOR USE IN AF SMALL SIGNAL AMPLIFIER STAGES AND DIRECT COUPLED CIRCUITS.

CASE TO-92B



<u>ABSOLUTE MAXIMUM RATINGS</u>	For p-p devices, voltage and current values are negative.				
		(PNP) <u>2SA564</u>	(PNP) <u>2SA564A</u>	(NPN) <u>2SC828</u>	(NPN) <u>2SC828A</u>
Collector-Base Voltage	V _{CB0}	25V	45V	30V	45V
Collector-Emitter Voltage	V _{CE0}	25V	45V	25V	45V
Emitter-Base Voltage	V _{EB0}	5V	5V	5V	5V
Collector Current	I _C			50mA	
Collector Peak Current	I _{CM}			100mA	
Total Power Dissipation (T _A ≤ 25°C)	P _{tot}			250mW	
				derate 2.5mW/°C above 25°C	
Operating Junction & Storage Temperature	T _j , T _{stg}			-55 to 125°C	

ELECTRICAL CHARACTERISTICS (T_A=25°C unless otherwise noted)

PARAMETER	SYMBOL	MIN	TYP	MAX	UNIT	TEST CONDITIONS
Collector-Base Breakdown Voltage	BV _{CB0}	Note 1			V	I _C =0.01mA I _B =0
Emitter-Base Breakdown Voltage	BV _{EB0}	5			V	I _E =0.01mA I _C =0
Collector Cutoff Current	I _{CB0}			10	μA	V _{CE} =V _{CE0} I _B =0
Collector Cutoff Current	I _{CB0}			1	μA	V _{CB} =10V I _E =0
Collector-Emitter Saturation Voltage	V _{CE(sat)}	0.15	0.4		V	I _C =50mA I _B =5mA
Base-Emitter Voltage	V _{BE}	0.68	0.8		V	I _C =10mA V _{CE} =5V
D.C. Current Gain (Note 2)	H _{FE}	65	300	700		I _C =2mA V _{CE} =5V
Current Gain-Bandwidth Product	f _T		150		MHz	I _C =2mA V _{CE} =10V
Collector-Base Capacitance	C _{ob}				pF	V _{CB} =10V I _E =0
	2SA564, 2SA564A		3.2		pF	f=1MHz
	2SC828, 2SC828A		2.5		pF	
Noise Figure	N _F		2		dB	I _C =0.2mA V _{CE} =5V R _G =2KΩ f=1kHz

Note 1 : equal to the value of V_{CB0} rating.

Note 2 : H_{FE} is classified as follows.

Group O : 65-130

Group P : 90-180

Group Q : 130-260

Group R : 180-360

Group S : 260-520

Group T : 360-700

2SA564 2SA564A 2SC828 2SC828A

TYPICAL CHARACTERISTICS ($T_A=25^\circ\text{C}$ UNLESS OTHERWISE SPECIFIED)

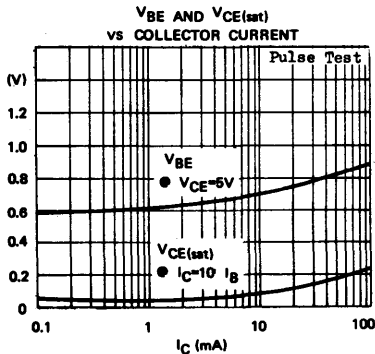
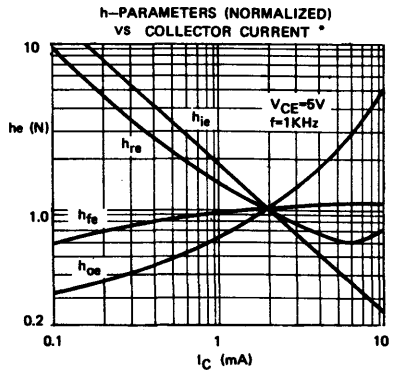
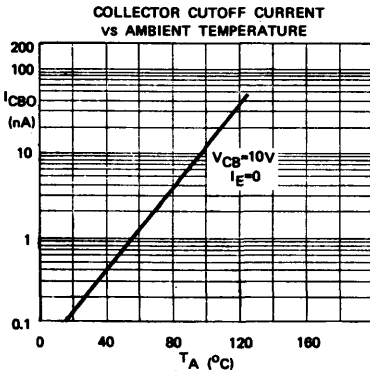
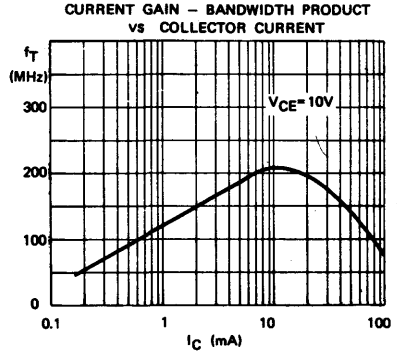
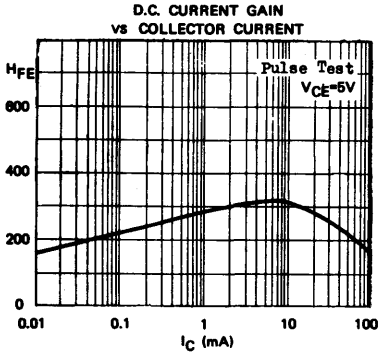

*Typical values at $I_C=2\text{mA}$ $V_{CE}=5\text{V}$	
$H_{FE}(\text{D.C.})$	300
$h_{ie}(1\text{KHz})$	4.5Kohms
$h_{re}(1\text{KHz})$	330
$h_{fe}(1\text{KHz})$	2×10^{-4}
$h_{oe}(1\text{KHz})$	30 μmhos

2SA666 2SC644

COMPLEMENTARY

SILICON AF LOW NOISE SMALL SIGNAL TRANSISTORS

THE 2SA666 (PNP) AND 2SC644 (NPN) ARE
 COMPLEMENTARY SILICON PLANAR EPITAXIAL
 TRANSISTORS FOR AF LOW NOISE PREAMPLIFIER
 APPLICATIONS.

CASE TO-92B



ECB

ABSOLUTE MAXIMUM RATINGS For pnp devices, voltage and current values are negative.

		<u>2SA666(PNP)</u>	<u>2SC644(NPN)</u>
Collector-Base Voltage	V _{CB0}	25V	30V
Collector-Emitter Voltage	V _{CE0}	25V	25V
Emitter-Base Voltage	V _{EB0}	5V	5V
Collector Current	I _C		50mA
Collector Peak Current	I _{CM}		100mA
Total Power Dissipation (T _A ≤ 25°C)	P _{tot}		250mW
		derate 2.5mW/°C above 25°C	
Operating Junction & Storage Temperature	T _j , T _{stg}	-55 to 125°C	

ELECTRICAL CHARACTERISTICS (T_A=25°C unless otherwise noted)

PARAMETER	SYMBOL	MIN	TYP	MAX	UNIT	TEST CONDITIONS
Collector-Base Breakdown Voltage	BV _{CB0}				V	I _C =0.01mA I _B =0
2SA666		25			V	
2SC644		30			V	
Emitter-Base Breakdown Voltage	BV _{EB0}	5			V	I _E =0.01mA I _C =0
Collector Cutoff Current	I _{CE0}			10	μA	V _{CE} =25V I _B =0
Collector Cutoff Current	I _{CB0}			1	μA	V _{CB} =10V I _E =0
Collector-Emitter Saturation Voltage	V _{CE(sat)}		0.15	0.4	V	I _C =50mA I _B =5mA
Base-Emitter Voltage	V _{BE}		0.68	0.8	V	I _C =10mA V _{CE} =5V
D.C. Current Gain (Note 1)	H _{FE}	130	300	700		I _C =2mA V _{CE} =5V
Noise Figure	NF					I _C =0.2mA V _{CE} =5V
2SA666 only				16	dB	(R _G =50KΩ f=100Hz)
2SC644 only				5	dB	(R _G =2KΩ f=100Hz)
2SC644 only				3	dB	(R _G =2KΩ f=1kHz)

Note 1 : H_{FE} is classified as follows.

GROUP Q : 130-260 GROUP R : 180-360 GROUP S : 260-520 GROUP T : 360-700

2SA666 2SC644

TYPICAL CHARACTERISTICS ($T_A=25^\circ\text{C}$ UNLESS OTHERWISE SPECIFIED)

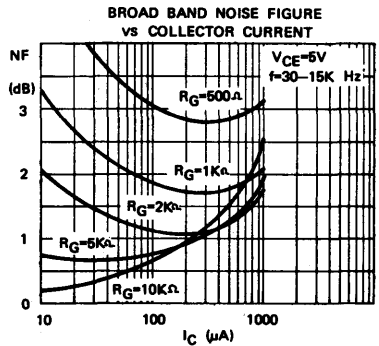
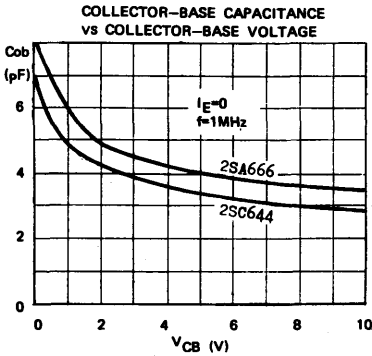
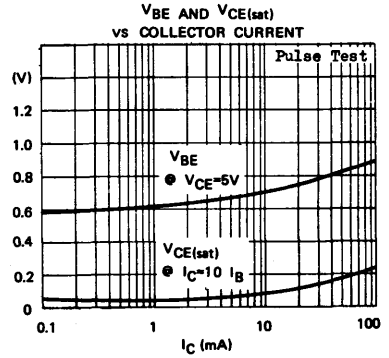
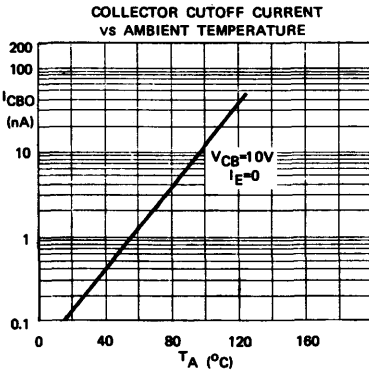
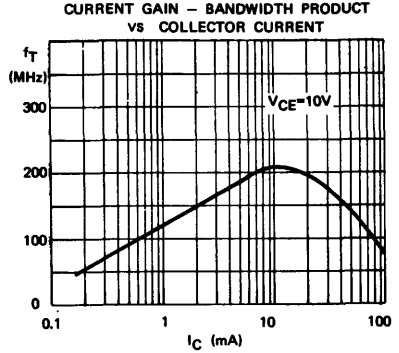
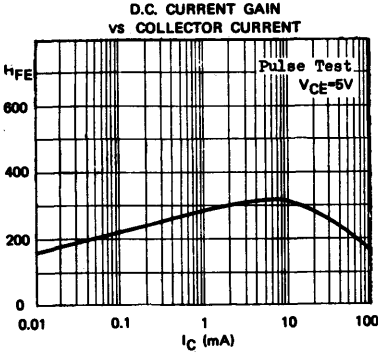

2.78.0450B/4500B

2SA671 2SC1061

PNP NPN SILICON EPITAXIAL BASE POWER TRANSISTORS

THE 2SA671 (PNP) AND 2SC1061 (NPN) ARE SILICON EPITAXIAL BASE COMPLEMENTARY PAIR SPECIALLY DESIGNED FOR 15-WATT AUDIO AMPLIFIER OUTPUT APPLICATIONS. THEY ARE ALSO SUITABLE FOR SWITCHING UP TO 3A COLLECTOR CURRENT.

CASE TO-220B



ABSOLUTE MAXIMUM RATINGS

For p-p values, voltage and current values are negative.

Collector-Base Voltage	V _{CB0}	50V
Collector-Emitter Voltage	V _{CE0}	50V
Emitter-Base Voltage	V _{EB0}	4V
Collector Current	I _c	3A
Collector Peak Current (t ≤ 10ms)	I _{CM}	6A
Total Power Dissipation (T _c ≤ 25°C)	P _{tot}	25W
Junction Temperature	T _j	150°C
Storage Temperature Range	T _{stg}	-55 to +150°C

ELECTRICAL CHARACTERISTICS (T_A=25°C unless otherwise noted)

PARAMETER	SYMBOL	MIN	TYP	MAX	UNIT	TEST CONDITIONS
Collector-Base Breakdown Voltage	V _{CB0}	50			V	I _c =0.1mA I _B =0
Collector-Emitter Breakdown Voltage	V _{CE0} *	50			V	I _c =50mA I _B =0
Collector Cutoff Current	I _{CB0}			100	μA	V _{CB} =50V I _B =0
Emitter Cutoff Current	I _{EB0}			100	μA	V _{EB} =4V I _C =0
Collector-Emitter Saturation Voltage	V _{CE(sat)} *	0.35	1		V	I _c =2A I _B =0.2A
Base-Emitter Voltage	V _{BE} *	0.85	1.5		V	I _c =1A V _{CE} =4V
D.C. Current Gain (Note)	h _{FE} 1 *	35	320			I _c =1A V _{CE} =4V
	h _{FE} 2 *	35				I _c =0.1A V _{CE} =4V
Current Gain-Bandwidth Product	f _T	3			MHz	I _c =0.5A V _{CE} =4V

* Pulse Test : Pulse Width=0.5ms, Duty Cycle=1%

Note : h_{FE} 1 is classified as follows.

Group A : 35-70
Group C : 100-200

Group B : 60-120
Group D : 160-320

TYPICAL CHARACTERISTICS

($T_A=25^\circ\text{C}$ unless otherwise noted)

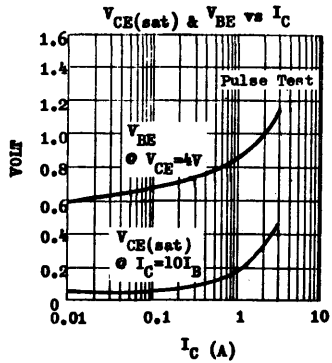
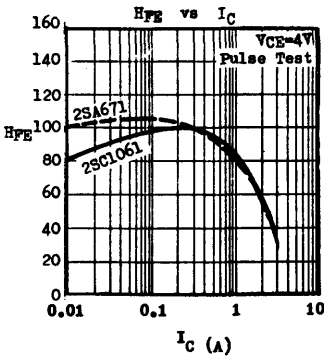
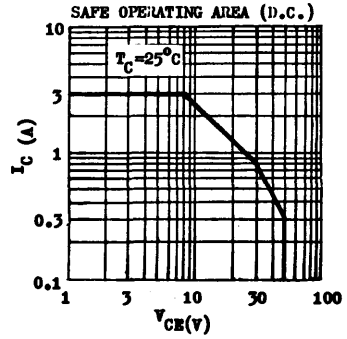
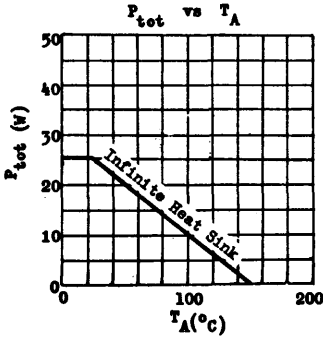

2SA719, 720 730, 731 2SC1317, 1318, 1346, 1347

COMPLEMENTARY SILICON AF MEDIUM POWER TRANSISTORS

THE ABOVE TYPES ARE COMPLEMENTARY SILICON PLANAR EPITAXIAL TRANSISTORS FOR AF MEDIUM POWER AMPLIFIER & SWITCHING APPLICATIONS. THE 2SA719, 2SC1317 ARE SPECIALLY RECOMMENDED FOR 1W OTL OUTPUT STAGE.

CASE T0-92B

WITH X-67 HEAT SINK



ECB

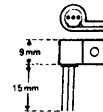

2SA719, 720
2SC1317, 1318

2SA730, 731
2SC1346, 1347

ABSOLUTE MAXIMUM RATINGS

	(PNP)	2SA719	2SA720	2SA730	2SA731
	(NPN)	2SC1317	2SC1318	2SC1346	2SC1347
Collector-Base Voltage	V _{CB0}	30V	60V	30V	60V
Collector-Emitter Voltage	V _{CE0}	25V	50V	25V	50V
Emitter-Base Voltage	V _{EB0}	5V	5V	5V	5V
Collector Current	I _C	0.5A	0.5A	0.5A	0.5A
Collector Peak Current	I _{CM}	1A	1A	1A	1A
Total Power Dissipation (T _A ≤ 25°C)	P _{tot}	0.4W	0.4W	0.6W	0.6W
Operating Junction & Storage Temperature	T _j , T _{stg}	-55 to 125°C			

ELECTRICAL CHARACTERISTICS (T_A = 25°C)

For p-n-p devices, voltage and current values are negative.

PARAMETER	SYMBOL	2SA TYPES			2SC TYPES			UNIT	TEST CONDITIONS
		MIN	TYP	MAX	MIN	TYP	MAX		
Collector-Base Breakdown Voltage	V _{CB0}	↑			↑			V	I _C =0.01mA I _B =0
Collector-Emitter Breakdown Voltage	V _{CE0} *	Note 1			Note 1			V	I _C =10mA I _B =0
Emitter-Base Breakdown Voltage	V _{EB0}	↓			↓			V	I _B =0.01mA I _C =0
Collector Cutoff Current	I _{CB0}	0.1			0.1			μA	V _{CB} =20V I _E =0
Collector-Emitter Saturation Voltage	V _{CE(sat)} *	0.25	0.6		0.25	0.6		V	I _C =500mA I _B =50mA
Base-Emitter Saturation Voltage	V _{BE(sat)} *	0.93	1.5		0.91	1.5		V	I _C =500mA I _B =50mA
D.C. Current Gain (Note 2)	h _{FE 1} *	60	180	340	60	180	340		I _C =150mA V _{CE} =10V
	h _{FE 2} *	40			40				I _C =500mA V _{CE} =10V
Current Gain-Bandwidth Product	f _t	160			200			MHz	I _C =50mA V _{CE} =10V
Output Capacitance	C _{ob}	12 15			8 15			pF	V _{CB} =10V I _B =0 f=1MHz

Note 1 : equal to the values of absolute maximum ratings.

Note 2 : h_{FE 1} is classified as follows : Group P : 60-120

Group R : 120-240

Group Q : 85-170

Group S : 170-340

* Pulse Test : Pulse Width=0.3mS, Duty Cycle=1%

2SA719, 720 730, 731 2SC1317, 1318, 1346, 1347

TYPICAL CHARACTERISTICS

($T_A=25^\circ\text{C}$ unless otherwise noted)

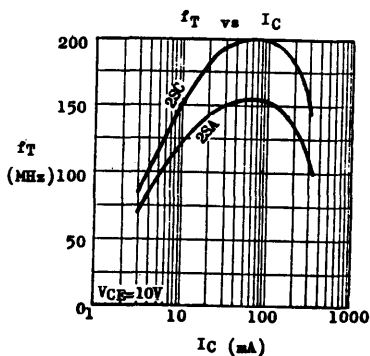
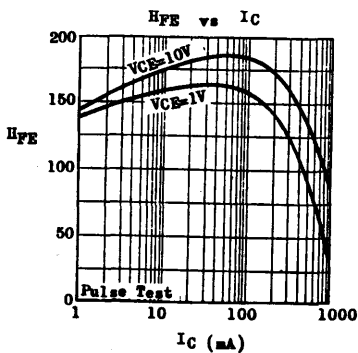
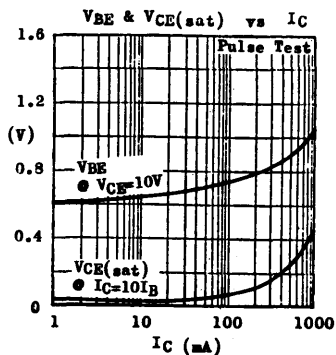
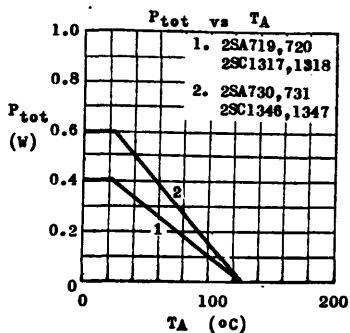

2SA816 2SC1626

PNP NPN SILICON PLANAR EPITAXIAL POWER TRANSISTORS

THE 2SA816 (PNP) AND 2SC1626 (NPN) ARE SILICON PLANAR EPITAXIAL COMPLEMENTARY PAIR SPECIALLY DESIGNED FOR THE DRIVER STAGES OF 30-50W HI-FI AMPLIFIERS. THEY ARE ALSO SUITABLE FOR MEDIUM SPEED SWITCHING UP TO 2A PEAK CURRENT.

CASE TO-220B



BCE

ABSOLUTE MAXIMUM RATINGS

For p-n-p device, voltage and current values are negative.

Collector-Base Voltage	V _{CB0}	80V
Collector-Emitter Voltage	V _{CE0}	80V
Emitter-Base Voltage	V _{EB0}	5V
Collector Current	I _c	750mA
Collector Peak Current (t ≤ 10μs)	I _{CM}	2A
Total Power Dissipation @ T _C ≤ 25°C	P _{tot}	10W
@ T _A ≤ 25°C		1.5W
Junction Temperature	T _j	150°C
Storage Temperature Range	T _{stg}	-55 to +150°C

ELECTRICAL CHARACTERISTICS (T_A=25°C unless otherwise noted)

PARAMETER	SYMBOL	MIN	TYP	MAX	UNIT	TEST CONDITIONS
Collector-Base Breakdown Voltage	BV _{CB0}	80			V	I _C =0.1mA I _B =0
Collector-Emitter Breakdown Voltage	LV _{CE0} *	80			V	I _C =10mA I _B =0
Collector Cutoff Current	I _{CB0}		0.5		μA	V _{CB} =30V I _B =0
Emitter Cutoff Current	I _{EB0}		1		μA	V _{EB} =5V I _C =0
Collector-Emitter Saturation Voltage	V _{CE(sat)} *		0.5		V	I _C =500mA I _B =50mA
Base-Emitter Voltage	V _{BE} *		1		V	I _C =500mA V _{CE} =2V
D.C. Current Gain (Note)	h _{FE 1} *	70	240			I _C =150mA V _{CE} =2V
	h _{FE 2} *	40				I _C =500mA V _{CE} =2V
Current Gain-Bandwidth Product	f _T	50	100		MHz	I _C =150mA V _{CE} =2V
Collector-Base Capacitance	C _{ob}		20		pF	V _{CB} =10V I _B =0
2SA816			13		pF	f=1MHz
2SC1626			13		pF	f=1MHz

*Pulse Test: Pulse Width=0.3μs, Duty Cycle=1%
 note: h_{FE 1} is classified as follows, Group 0: 70-140, Group Y: 120-240

2SA816 2SC1626

TYPICAL CHARACTERISTICS

($T_A=25^\circ\text{C}$ unless otherwise noted)

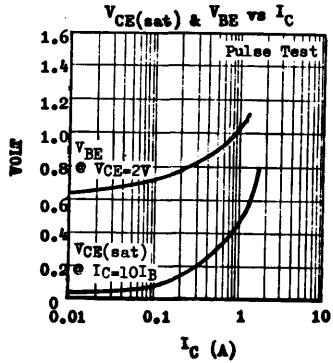
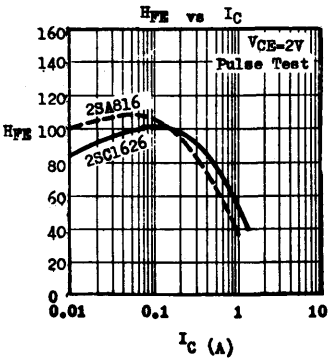
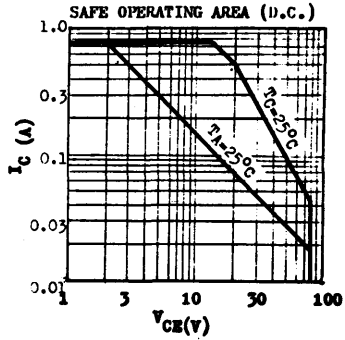
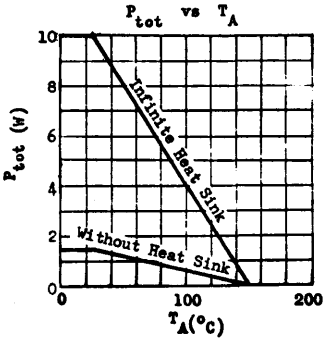

2SA817 2SC1627

COMPLEMENTARY SILICON AF LARGE SIGNAL TRANSISTORS

THE 2SA817 (PNP) AND 2SC1627 (NPN) ARE SILICON PLANAR EPITAXIAL TRANSISTORS DESIGNED FOR AF LARGE SIGNAL AMPLIFIERS. THEY ARE SPECIALLY SUITED FOR THE DRIVER STAGES OF 30W AMPLIFIERS.

CASE T0-92B



ABSOLUTE MAXIMUM RATINGS For p-n-p device, voltage and current values are negative.

Collector-Base Voltage	V _{CB0}	80V
Collector-Emitter Voltage	V _{CE0}	80V
Emitter-Base Voltage	V _{EB0}	5V
Collector Current	I _C	300mA
Collector Peak Current	I _{CM}	1A
Total Power Dissipation (T _C ≤ 25°C)	P _{tot}	1.3W
(T _A ≤ 25°C)		0.6W
Operating Junction & Storage Temperature	T _j , T _{stg}	-55 to 150°C

ELECTRICAL CHARACTERISTICS (T_A=25°C)

PARAMETER	SYMBOL	MIN	TYP	MAX	UNIT	TEST CONDITIONS
Collector-Emitter Breakdown Voltage	V _{CE0} *	80			V	I _C =5mA I _B =0
Collector Cutoff Current	I _{CB0}			0.1	μA	V _{CB} =50V I _B =0
Emitter Cutoff Current	I _{EB0}			0.1	μA	V _{EB} =5V I _C =0
Collector-Emitter Saturation Voltage	V _{CE(sat)} *		0.15	0.4	V	I _C =200mA I _B =20mA
Base-Emitter Voltage	V _{BE} *	0.55	0.65	0.8	V	I _C =5mA V _{CE} =2V
D.C. Current Gain (Note)	h _{FE 1} *	70		240		I _C =50mA V _{CE} =2V
	h _{FE 2} *	40				I _C =200mA V _{CE} =2V
Current Gain-Bandwidth Product	f _T		100		MHz	I _C =10mA V _{CE} =10V
Output Capacitance	C _{ob}					
	2SA817		17		pF	V _{CB} =10V I _B =0 f=1MHz
	2SC1627		10		pF	V _{CB} =10V I _B =0 f=1MHz

* Pulse Test : Pulse Width=0.3ms, Duty Cycle=1%

Note : h_{FE 1} is classified as follows.

GROUP O : 70-140 GROUP Y : 120-240

TYPICAL CHARACTERISTICS

($T_A=25^\circ\text{C}$ unless otherwise noted)

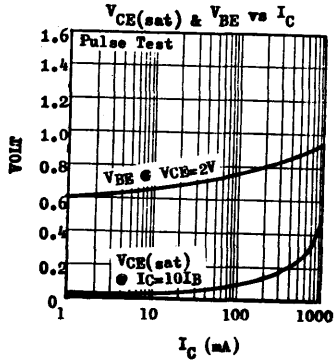
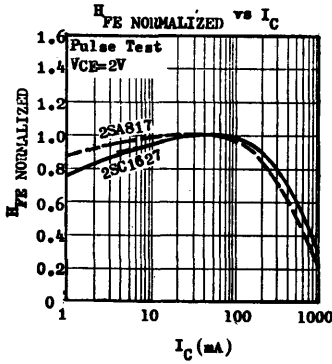
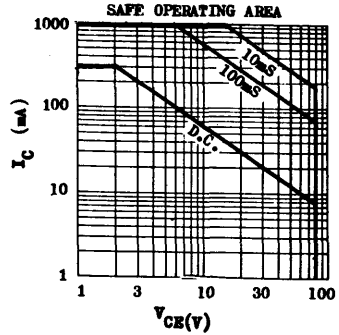
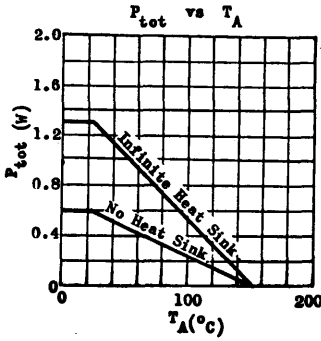

2SB512 2SB512A 2SD365 2SD365A

PNP NPN SILICON EPITAXIAL BASE POWER TRANSISTORS

THE 2SB512, 2SB512A (PNP) AND 2SD365, 2SD365A (NPN) ARE SILICON PLANAR EPITAXIAL BASE POWER TRANSISTORS OF COMPLEMENTARY CHARACTERISTICS. THEY ARE INTENDED FOR 10 TO 20W AUDIO AMPLIFIER OUTPUTS AND SWITCHING APPLICATIONS UP TO 3A COLLECTOR CURRENT.

CASE TO-220B



ABSOLUTE MAXIMUM RATINGS

For power devices, voltage and current values are averages

		2SB512 (PNP) 2SD365 (NPN)	2SB512A (PNP) 2SD365A (NPN)
Collector-Base Voltage	V _{CB0}	60V	80V
Collector-Emitter Voltage	V _{CE0}	60V	80V
Emitter-Base Voltage	V _{EB0}		5V
Collector Current	I _C	3A	
Collector Peak Current (t ≤ 10ms)	I _{CM}	6A	
Total Power Dissipation (T _C ≤ 25°C)	P _{tot}	25W	
Junction Temperature	T _j	150°C	
Storage Temperature Range	T _{stg}	-55 to +150°C	

ELECTRICAL CHARACTERISTICS (T_A=25°C unless otherwise noted)

PARAMETER	SYMBOL	MIN	TYP	MAX	UNIT	TEST CONDITIONS
Collector-Base Breakdown Voltage 2SB512, 2SD365	BV _{CB0}	60			V	I _C =0.1mA I _E =0
		80			V	
Collector-Base Breakdown Voltage 2SB512A, 2SD365A	LV _{CB0} *	60			V	I _C =100mA I _B =0
		80			V	
Collector Cutoff Current	I _{CB0}			30	μA	V _{CB} =20V I _E =0
Emitter Cutoff Current	I _{EB0}			1	mA	V _{EB} =5V I _C =0
Collector-Emitter Saturation Voltage	V _{CE(sat)} *	0.28	1		V	I _C =2A I _B =0.4A
Base-Emitter Voltage	V _{BE} *	0.83	1.4		V	I _C =1A V _{CE} =3V
D.C. Current Gain (note)	HFE 1 *	30	160			I _C =1A V _{CE} =3V
	HFE 2 *	40				I _C =0.1A V _{CE} =3V
Current Gain-Bandwidth Product	f _T	3			MHz	I _C =0.2A V _{CE} =10V

* Pulse Test : Pulse Width=0.3ms, Duty Cycle=1%

note : HFE 1 is classified as follows. Group Q : 30-60 Group P : 50-100 Group O : 80-160

2SB512 2SB512A 2SD365 2SD365A

TYPICAL CHARACTERISTICS

($T_A=25^\circ\text{C}$ unless otherwise noted)

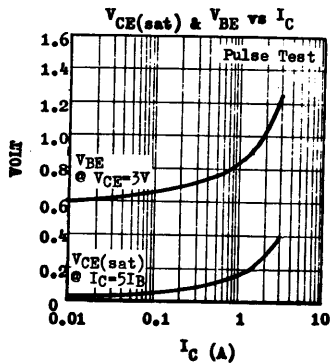
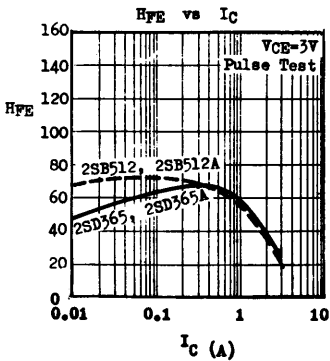
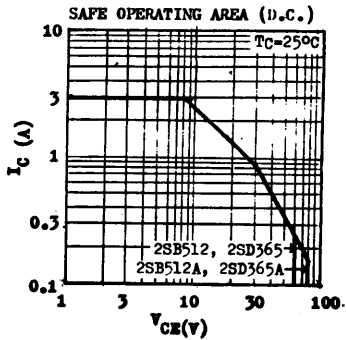
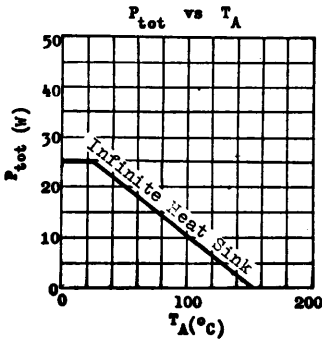

2SC789 2SD570 2SD526

NPN SILICON EPITAXIAL BASE POWER TRANSISTORS

THE 2SC789, 2SD570, 2SD526 ARE NPN SILICON EPITAXIAL BASE POWER TRANSISTORS DESIGNED FOR 20 TO 25W AUDIO AMPLIFIER OUTPUTS AND SWITCHING APPLICATIONS UP TO 4A COLLECTOR CURRENT. THE 2SC789, 2SD570 AND 2SD526 ARE COMPLEMENTARY TO 2SA489, 2SB604 AND 2SB596 RESPECTIVELY.

CASE TO-220B



ABSOLUTE MAXIMUM RATINGS

Collector-Base Voltage

Collector-Emitter Voltage

Emitter-Base Voltage

Collector Current

Collector Peak Current ($t \leq 10\text{ms}$)

Total Power Dissipation ($T_C \leq 25^\circ\text{C}$)

Junction Temperature

Storage Temperature Range

	2SC789	2SD570	2SD526
VCBO	70V	70V	80V
VCEO	60V	70V	80V
VEBO		5V	
IC		4A	
ICM		8A	
P _{tot}		30W	
T _j		150°C	
T _{stg}		-55 to +150°C	

THERMAL RESISTANCE

Junction to Case

θ_{jc} 4.17°C/W max.

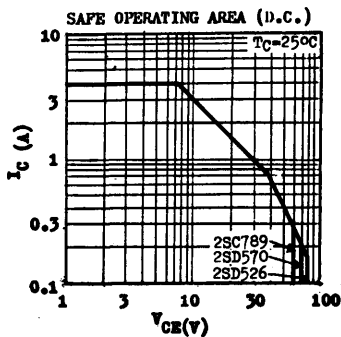
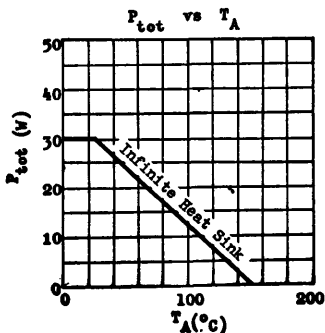

2SC789 2SD570 2SD526

ELECTRICAL CHARACTERISTICS (TA=25°C unless otherwise noted)

PARAMETER	SYMBOL	MIN	TYP	MAX	UNIT	TEST CONDITIONS
Collector-Base Breakdown Voltage	BV_{CBO}	70			V	$I_C=0.1mA$ $I_B=0$
2SC789		70			V	
2SD570		70			V	
2SD526		80			V	
Collector-Emitter Breakdown Voltage	LV_{CEO}^*	60			V	$I_C=100mA$ $I_B=0$
2SC789		70			V	
2SD570		80			V	
2SD526						
Collector Cutoff Current	I_{CBO}			30	μA	$V_{CB}=50V$ $I_E=0$
2SC789				30	μA	$V_{CB}=50V$ $I_E=0$
2SD570				30	μA	$V_{CB}=80V$ $I_E=0$
2SD526						
Emitter Cutoff Current	I_{EBO}			100	μA	$V_{EB}=5V$ $I_C=0$
Collector-Emitter Saturation Voltage	$V_{CE(sat)}^*$	0.4	1.5		V	$I_C=3A$ $I_B=0.3A$
Base-Emitter Voltage	V_{BE}^*		1.0	1.5	V	$I_C=2.5A$ $V_{CE}=5V$
2SC789			1.03	1.5	V	$I_C=3A$ $V_{CE}=5V$
2SD570			1.03	1.5	V	$I_C=3A$ $V_{CE}=5V$
2SD526						
D.C. Current Gain (note)	$H_{FE} 1^*$	40	240			$I_C=0.5A$ $V_{CE}=5V$
	$H_{FE} 2^*$	15				$I_C=3A$ $V_{CE}=5V$
Current Gain-Bandwidth Product	f_T	3			MHz	$I_C=0.5A$ $V_{CE}=5V$

* Pulse Test : Pulse Width=0.3ms, Duty Cycle=1%

note : $H_{FE} 1$ is classified as follows . Group R : 40-80 Group O : 70-140
Group Y : 120-240

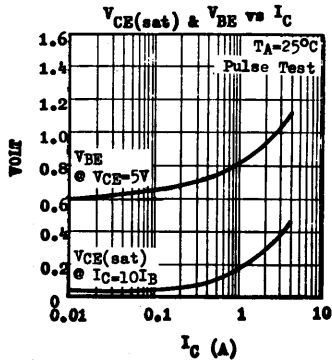
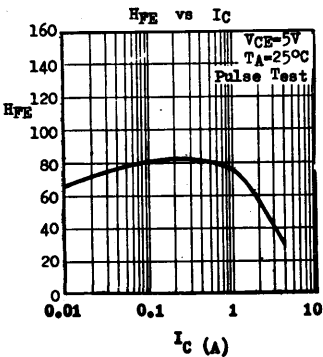

12.77.8500E

2SC829

NPN SILICON RF SMALL SIGNAL TRANSISTOR

THE 2SC829 IS AN NPN SILICON PLANAR EPITAXIAL TRANSISTOR FOR RF SMALL SIGNAL APPLICATIONS SUCH AS HF, OSC, MIXER AND IF STAGES IN FM/AM RADIO SETS.

CASE T0-92B

ABSOLUTE MAXIMUM RATINGS

Collector-Base Voltage	V _{CB0}	30V
Collector-Emitter Voltage	V _{CE0}	20V
Emitter-Base Voltage	V _{EB0}	5V
Collector Current	I _C	30mA
Total Power Dissipation (T _A ≤25°C)	P _{tot}	250mW
		derate 2.5mW/°C above 25°C
Operating Junction & Storage Temperature	T _j , T _{stg}	-55 to 125°C

ELECTRICAL CHARACTERISTICS (T_A=25°C)

PARAMETER	SYMBOL	MIN	TYP	MAX	UNIT	TEST CONDITIONS
Collector-Base Breakdown Voltage	BV _{CB0}	30			V	I _C =0.01mA I _B =0
Collector-Emitter Breakdown Voltage	LV _{CE0}	20			V	I _C =2mA (Pulsed) I _B =0
Emitter-Base Breakdown Voltage	BV _{EB0}	5			V	I _B =0.01mA I _C =0
Collector-Emitter Saturation Voltage	V _{CE(sat)}		0.1		V	I _C =10mA I _B =1mA
Base-Emitter Voltage	V _{BE}		0.68		V	I _C =1mA V _{CE} =10V
D.C. Current Gain	h _{FE} *	40		250		I _C =1mA V _{CE} =10V
Current Gain-Bandwidth Product	f _T	150	230		MHz	I _C =1mA V _{CE} =10V
Feedback Capacitance (Common Emitter)	C _{re}		1.3	1.6	pF	I _C =1mA V _{CE} =10V f=10.7MHz
Feedback Impedance (Common Base)	Z _{rb}			60	Ω	-I _E =1mA V _{CB} =10V

* h_{FE} is classified as follows.

GROUP A : 40-100

GROUP B : 70-160

GROUP C : 110-250

TYPICAL CHARACTERISTICS AT $T_A=25^\circ\text{C}$

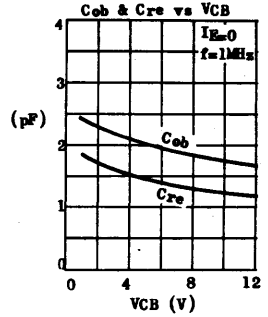
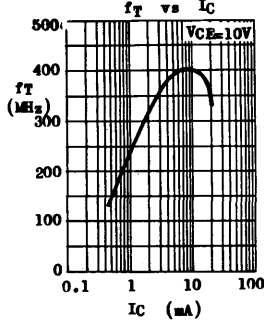
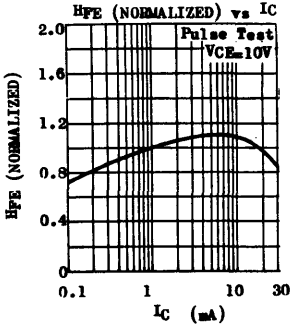

TYPICAL γ -PARAMETERS AT $T_A=25^\circ\text{C}$

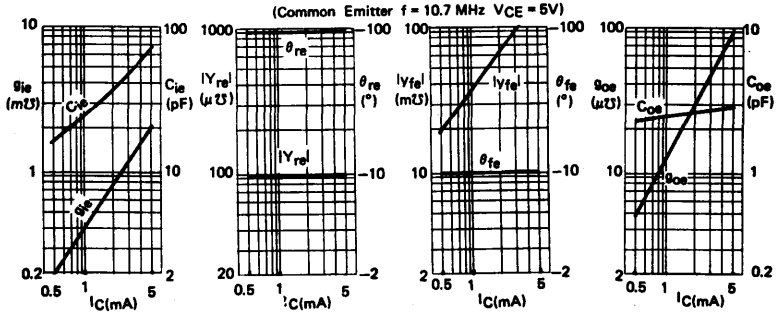

2SC838 2SC839

NPN SILICON RF SMALL SIGNAL TRANSISTORS

THE 2SC838, 2SC839 ARE NPN SILICON PLANAR EPITAXIAL TRANSISTORS FOR RF SMALL SIGNAL APPLICATIONS. THEY ARE SPECIALLY SUITED FOR RF AMPLIFIER, OSCILLATOR, MIXER, AND IF AMPLIFIER IN FM/AM RADIO SETS.

CASE TO-92B



ABSOLUTE MAXIMUM RATINGS

Collector-Base Voltage	V _{CB0}	50V
Collector-Emitter Voltage	V _{CE0}	25V
Emitter-Base Voltage	V _{EB0}	5V
Collector Current	I _C	50mA
Total Power Dissipation (T _A ≤ 25°C)	P _{tot}	250mW derate 2.5mW/°C above 25°C
Operating Junction & Storage Temperature	T _j , T _{stg}	-55 to 125°C

ELECTRICAL CHARACTERISTICS (T_A=25°C unless otherwise noted)

PARAMETER	SYMBOL	MIN	TYP	MAX	UNIT	TEST CONDITIONS
Collector Cutoff Current	I _{CB0}			100	nA	V _{CB} =15V I _E =0
Emitter Cutoff Current	I _{EB0}			100	nA	V _{EB} =3V I _C =0
Collector-Emitter Saturation Voltage	V _{CE(sat)}	0.1	0.3		V	I _C =10mA I _B =1mA
Base-Emitter Voltage	V _{BE}	0.67			V	I _C =1mA V _{CE} =6V
D.C. Current Gain (Note 1)	H _{FE}	30	180			I _C =0.5mA V _{CE} =3V
Current Gain-Bandwidth Product	f _T	150	250		MHz	I _C =1mA V _{CE} =6V
Collector-Base Capacitance	C _{ob}	1.9	2.5		pF	V _{CB} =6V I _E =0 f=1MHz
Feedback Capacitance	C _{re}	1.3	1.8		pF	V _{CB} =6V I _E =0 f=1MHz
Feedback Time Constant	C _c f _{bb} '	25	50		pS	I _C =10mA V _{CE} =6V f=31.8MHz
Noise Figure	NF					I _C =0.5mA V _{CE} =6V R _C =500Ω f=1MHz
	2SC839 only	2.5	4		dB	

Note 1 : H_{FE} is classified as follow.

Group J : 30-80

Group H : 60-120

Group F : 90-180

TYPICAL CHARACTERISTICS AT TA=25°C

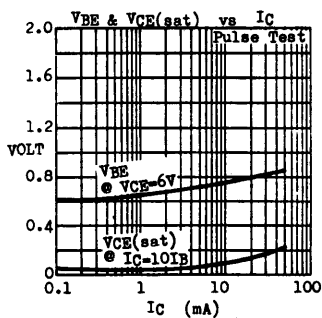
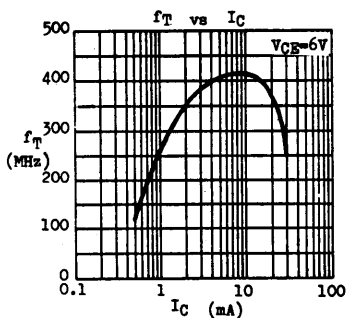
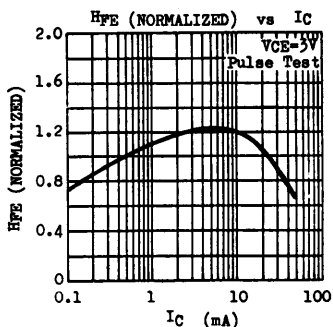
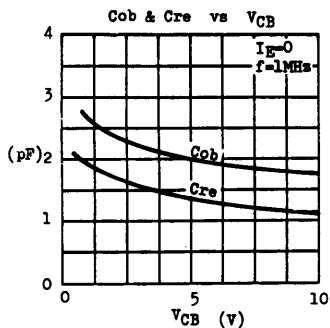

2SC922 2SC1047

NPN SILICON RF SMALL SIGNAL TRANSISTORS

THE 2SC922, 2SC1047 ARE NPN SILICON PLANAR EPITAXIAL TRANSISTORS FOR USE IN RF AND CONVERTER STAGES IN FM/AM RADIO SETS.

CASE TO-92B



ABSOLUTE MAXIMUM RATINGS

		<u>2SC922</u>	<u>2SC1047</u>
Collector-Base Voltage	VCBO	30V	30V
Collector-Emitter Voltage	VCEO	20V	20V
Emitter-Base Voltage	VEBO	5V	3V
Collector Current	IC	20mA	15mA
Total Power Dissipation ($T_A \leq 25^\circ\text{C}$)	Ptot	250mW	150mW
Operating Junction & Storage Temperature	Tj, Tstg	-55 to 125°C	

ELECTRICAL CHARACTERISTICS ($T_A=25^\circ\text{C}$)

PARAMETER	SYMBOL	2SC922		2SC1047		UNIT	TEST CONDITIONS
		MIN	MAX	MIN	MAX		
Collector Cutoff Current	ICBO	0.1		10		μA μA	VCB=20V $I_E=0$ VCB=30V $I_E=0$
Emitter Cutoff Current	IEBO	0.1		10		μA	VEB=3V $I_C=0$
D.C. Current Gain (Note)	HFE	40	180	40	160		$I_C=1\text{mA}$ $V_{CE}=6\text{V}$
Current Gain-Bandwidth Product	fT	400		450		MHz	$I_C=1\text{mA}$ $V_{CE}=6\text{V}$
Feedback Capacitance	Cre	1.2		1.0		pF	VCB=10V $I_E=0$ f=1MHz
						pF	VCE=6V $I_C=1\text{mA}$ f=10.7MHz
Collector-Base Time Constant	Ccrbb'	22				pS	$I_C=1\text{mA}$ $V_{CE}=6\text{V}$ f=31.8MHz
Power Gain	Gpe	20		20		dB	$I_C=1\text{mA}$ $V_{CE}=6\text{V}$ f=100MHz
Noise Figure	NF	5		5		dB	$I_C=1\text{mA}$ $V_{CE}=6\text{V}$ $R_G=50\Omega$ f=100MHz

Note : The HFE of 2SC922 is classified as follows — GROUP M : 40-80 GROUP L : 60-120
GROUP K : 90-180

The HFE of 2SC1047 is classified as follows — GROUP B : 40-110 GROUP C : 65-160

2SC922 2SC1047

TYPICAL CHARACTERISTICS AT $T_A=25^\circ\text{C}$

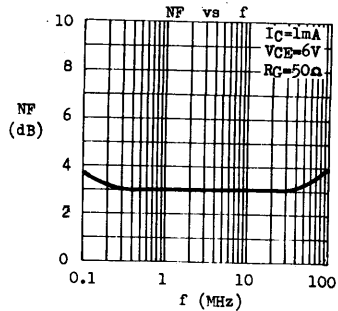
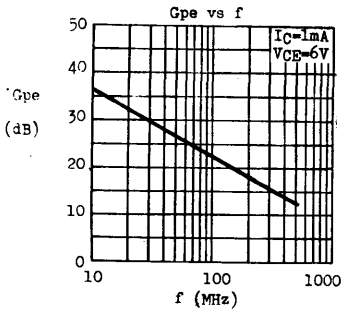
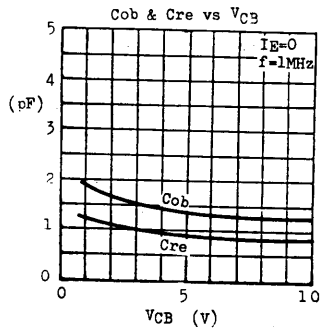
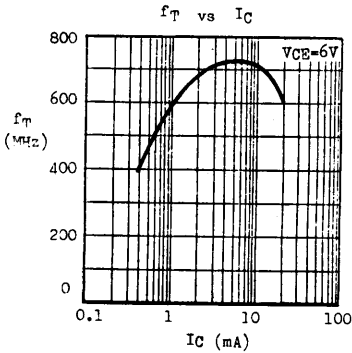
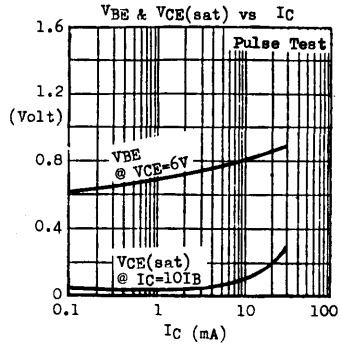
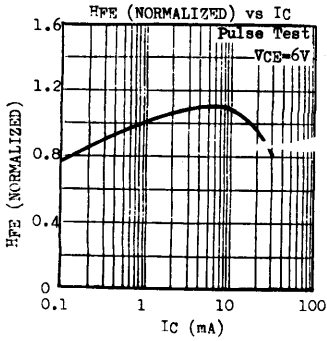

3.78.3100B

2SC1048

NPN SILICON HIGH VOLTAGE VIDEO AMPLIFIER

THE 2SC1048 IS AN NPN SILICON PLANAR TRANSISTOR DESIGNED FOR VIDEO AMPLIFIERS IN TELEVISION RECEIVERS AS WELL AS FOR HIGH VOLTAGE SWITCHING UP TO 100mA CURRENT.

CASE TO-39

ABSOLUTE MAXIMUM RATINGS

Collector-Base Voltage	V _{CB0}	200V
Collector-Emitter Voltage	V _{CE0}	200V
Emitter-Base Voltage	V _{EB0}	6V
Collector Current	I _C	50mA
Collector Peak Current	I _{CM}	100mA
Total Power Dissipation (T _C ≤ 25°C) (T _A ≤ 25°C)	P _{tot}	4W 600mW
Operating Junction & Storage Temperature	T _J , T _{stg}	-55 to 150°C

ELECTRICAL CHARACTERISTICS (T_A=25°C unless otherwise noted)

PARAMETER	SYMBOL	MIN	MAX	UNIT	TEST CONDITIONS
Collector-Base Breakdown Voltage	BV _{CB0}	200		V	I _C =0.1mA I _E =0
Collector-Emitter Breakdown Voltage	LV _{CE0}	200		V	I _C =3mA (Pulsed) I _B =0
Emitter-Base Breakdown Voltage	BV _{EB0}	6		V	I _E =0.1mA I _C =0
Collector Cutoff Current	I _{CBO}		10	μA	V _{CB} =100V I _E =0
Collector-Emitter Saturation Voltage	V _{CE(sat)}		1.3	V	I _C =25mA I _B =2.5mA
D.C. Current Gain	H _{FE} *	40	200		I _C =25mA V _{CE} =10V
Current Gain-Bandwidth Product	f _T	40		MHz	I _C =10mA V _{CE} =10V
Collector-Base Capacitance	C _{ob}		4.2	pF	V _{CB} =10V I _E =0 f=1MHz

* H_{FE} is classified as follows.

Group C : 40-80

Group D : 60-120

Group E : 100-200

TYPICAL CHARACTERISTICS ($T_A=25^\circ\text{C}$ unless otherwise noted)

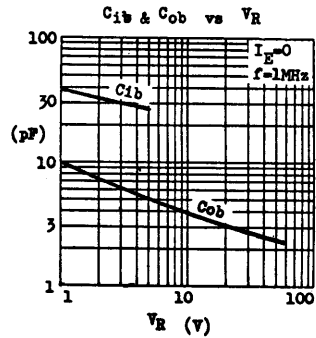
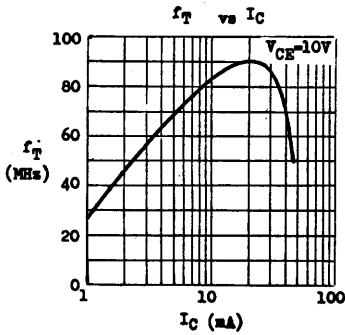
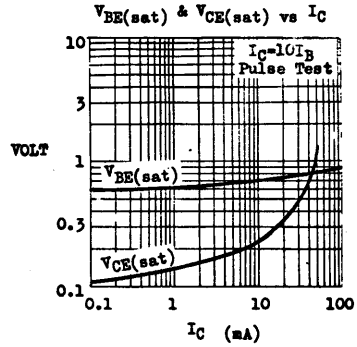
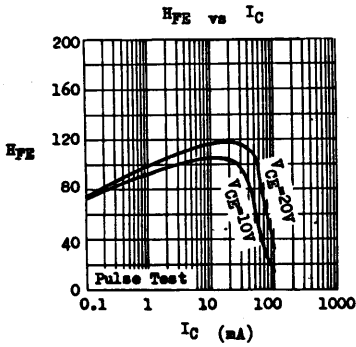

2SD234 2SD235

NPN SILICON SINGLE DIFFUSED MESA POWER TRANSISTORS

THE 2SD 234, 2SD 235 ARE NPN SILICON SINGLE DIFFUSED MESA POWER TRANSISTORS DESIGNED FOR LOW SPEED SWITCHING AND AUDIO POWER AMPLIFIER APPLICATIONS. THEY FEATURE LARGE SAFE OPERATING AREA.

CASE TO-220B



ABSOLUTE MAXIMUM RATINGS

Collector-Base Voltage	V_{CB0}
Collector-Emitter Voltage	V_{CE0}
Emitter-Base Voltage	V_{EB0}
Collector Current	I_C
Total Power Dissipation	P_{tot}
	@ $T_C \leq 25^\circ C$
	@ $T_A \leq 25^\circ C$
Junction Temperature	T_j
Storage Temperature Range	T_{stg}

	2SD 234	2SD 235
V_{CB0}	60V	50V
V_{CE0}	50V	40V
V_{EB0}		10V
I_C		3A
P_{tot}	25W	1.5W
T_j	150°C	
T_{stg}	-55 to +150°C	

THERMAL RESISTANCE

Junction to Case	θ_{jc}
Junction to Ambient	θ_{ja}

θ_{jc}	5°C/W max.
θ_{ja}	83°C/W max.

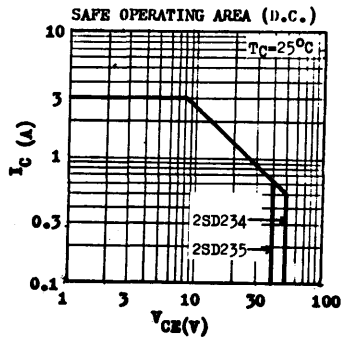
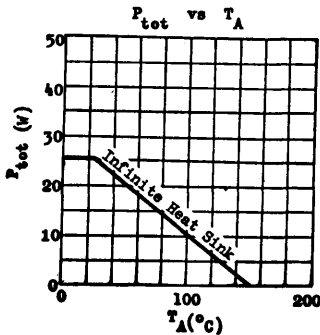

2SD234 2SD235

ELECTRICAL CHARACTERISTICS ($T_A=25^\circ\text{C}$ unless otherwise noted)

PARAMETER	SYMBOL	MIN	TYP	MAX	UNIT	TEST CONDITIONS
Collector-Base Breakdown Voltage	BV _{CB0}	60			V	I _C =10mA I _B =0
		50			V	
Collector-Emitter Breakdown Voltage	LV _{CE0} *	50			V	I _C =100mA I _B =0
		40			V	
Emitter-Base Breakdown Voltage	BV _{EB0}	10			V	I _E =10mA I _C =0
Collector Cutoff Current	I _{CBO}			100	μA	V _{CB} =20V I _E =0
Emitter Cutoff Current	I _{EB0}			100	μA	V _{EB} =5V I _C =0
Collector-Emitter Saturation Voltage	V _{CE(sat)} *	0.5	1.2		V	I _C =3A I _B =0.3A
		0.23	1		V	I _C =1A I _B =0.05A
2SD 235						
Base-Emitter Voltage	V _{BE} *	0.68	0.9		V	I _C =0.5A V _{CE} =5V
D.C. Current Gain	H _{FE} 1 *	40	240			I _C =0.5A V _{CE} =5V
D.C. Current Gain	H _{FE} 2 *	15	20			I _C =2.5A V _{CE} =5V
		20				I _C =1A V _{CE} =5V
2SD 235						
Current Gain-Bandwidth Product	f _T	0.8	1.5		MHz	I _B =0.2A V _{CE} =5V
Collector-Base Capacitance	C _{ob}	250			pF	V _{CB} =10V I _E =0 f=1MHz

* Pulse Test : Pulse Width=0.3ms, Duty Cycle=1%

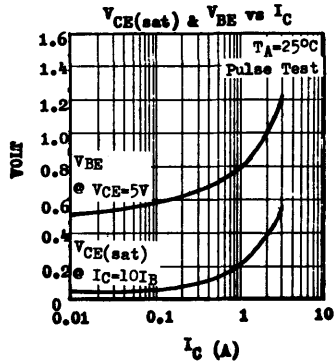
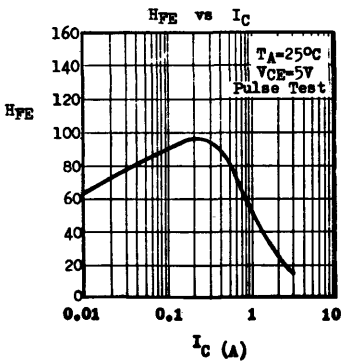

MECHANICAL OUTLINES

(All dimensions in inches unless otherwise noted)

T0-3

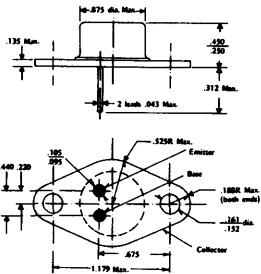

T0-18

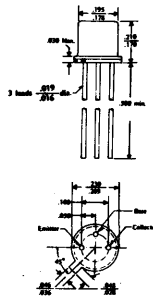

T0-39

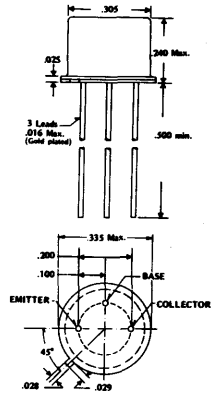

T0-72

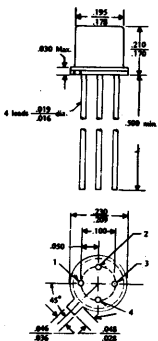

JFET

- 1 - S
- 2 - D
- 3 - G
- 4 - Case

SCS

- 1 - K
- 2 - Gk
- 3 - Ga (Case)
- 4 - A

T0-92

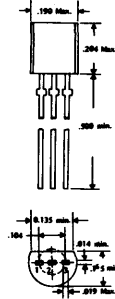

Lead Code	123
T0-92A	EBC
T0-92B	ECB
*T0-92E	CEB
*T0-92F	CBE
T0-92DA	SGD
T0-92DD	DSG
*T0-92DE	GSD

*Leads pre-formed to T0-106 spacings.

T0-106

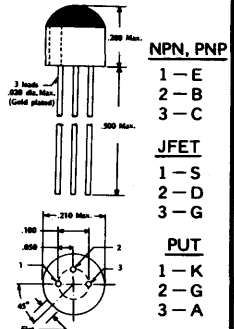

NPN, PNP

- 1 - E
- 2 - B
- 3 - C

JFET

- 1 - S
- 2 - D
- 3 - G

PUT

- 1 - K
- 2 - G
- 3 - A

T0-220B

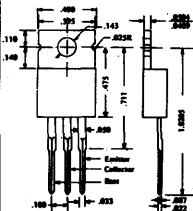

T0-220A

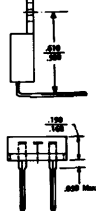

MT-42 (MINIATURE)

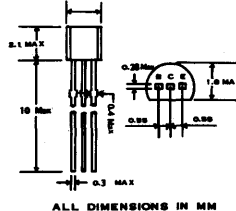

ALL DIMENSIONS IN MM

**X-67 HEAT SINK
mounted to T0-92**

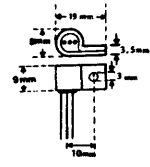

HONG KONG

MICRO ELECTRONICS LTD.
38 HUNG TO ROAD,
KWUN TONG, KOWLOON, HONG KONG
TELS: 3-430181-6, 3-893363, 3-892423
CABLE: MICROTRON, HONG KONG
TELEX: 73510 MICRO HX
P. O. BOX 9477, KWUN TONG, HONG KONG

ME

LONDON, U.K.

MICRO ELECTRONICS LTD.
YORK HOUSE, EMPIRE WAY,
WEMBLEY, MIDDLESEX,
U.K.
TEL: 01-903-2721
CABLE: MICROTRON, WEMBLEY, U.K.
TELEX: 934263 MICROE G

MUNICH, WEST GERMANY

M.E. MICRO ELECTRONICS GMBH
NORDENDSTR. 1A
8000 MUENCHEN 40
WEST GERMANY
TEL: 089/282048
CABLE: MICROTRONICS, GERMANY
TELEX: 5216194 MICR D

CALIFORNIA, U.S.A.

MICRO ELECTRONICS CORPORATION
3001 REDHILL AVENUE, 2/106
COSTA MESA
CALIF. 92626
U.S.A.
TEL: 714-549-0375
TELEX: 910-595-1759 MICROELEC CSMA

SYDNEY, AUSTRALIA

M.E. MICRO ELECTRONICS PTY.LTD.
P.O. BOX C347
SUITE 32 TRADE CREDITS HOUSE
160 CLARENCE STREET,
SYDNEY 2000
N.S.W.
AUSTRALIA
TEL: 02 290-1924
TELEX: 23361 MICROS

TRANSISTORS & ICS DATABOOK

ISSUE 1